



Public Utilities Commission

Application to Commit Energy
Efficiency/Peak Demand
Reduction Programs
(Mercantile Customers Only)

Case No.: 17-0164-EL-EEC

Mercantile Customer: **Miami University**

Electric Utility: **Duke Energy**

Program Title or
Description: **Hahne Hall Dorm Building Upgrade**

Rule 4901:1-39-05(F), Ohio Administrative Code (O.A.C.), permits a mercantile customer to file, either individually or jointly with an electric utility, an application to commit the customer's existing demand reduction, demand response, and energy efficiency programs for integration with the electric utility's programs. The following application form is to be used by mercantile customers, either individually or jointly with their electric utility, to apply for commitment of such programs in accordance with the Commission's pilot program established in Case No. 10-834-EL-POR

Completed applications requesting the cash rebate reasonable arrangement option (Option 1) in lieu of an exemption from the electric utility's energy efficiency and demand reduction (EEDR) rider will be automatically approved on the sixty-first calendar day after filing, unless the Commission, or an attorney examiner, suspends or denies the application prior to that time. Completed applications requesting the exemption from the EEDR rider (Option 2) will also qualify for the 60-day automatic approval so long as the exemption period does not exceed 24 months. Rider exemptions for periods of more than 24 months will be reviewed by the Commission Staff and are only approved up the issuance of a Commission order.

Complete a separate application for each customer program. Projects undertaken by a customer as a single program at a single location or at various locations within the same service territory should be submitted together as a single program filing, when possible. Check all boxes that are applicable to your program. For each box checked, be sure to complete all subparts of the question, and provide all requested additional information. Submittal of incomplete applications may result in a suspension of the automatic approval process or denial of the application.

Any confidential or trade secret information may be submitted to Staff on disc or via email at ee-pdr@puc.state.oh.us.

Section 1: Mercantile Customer Information

Name: **Miami University**

Principal address: **4955 Oxford Trenton Rd.
Oxford, OH 45056**

Address of facility for which this energy efficiency program applies:

**4955 Oxford Trenton Rd.
Oxford, OH 45056**

Name and telephone number for responses to questions:

Andrew Taylor, (317) 838-2096

Electricity use by the customer (check the box(es) that apply):

- The customer uses more than seven hundred thousand kilowatt hours per year at the above facility. (Refer to Appendix A for documentation.)
- The customer is part of a national account involving multiple facilities in one or more states. (Please attach documentation.)

Section 2: Application Information

A) The customer is filing this application (choose which applies):

- Individually, without electric utility participation.
- Jointly with the electric utility.

B) The electric utility is: **Duke Energy**

C) The customer is offering to commit (check any that apply):

- Energy savings from the customer's energy efficiency program. (Complete Sections 3, 5, 6, and 7.)
- Capacity savings from the customer's demand response/demand reduction program. (Complete Sections 4, 5, 6, and 7.)
- Both the energy savings and the capacity savings from the customer's energy efficiency program. (Complete all sections of the Application.)

Section 3: Energy Efficiency Programs

A) The customer's energy efficiency program involves (check those that apply):

- Early replacement of fully functioning equipment with new equipment. (Provide the date on which the customer replaced fully functioning equipment, and the date on which the customer would have replaced such equipment if it had not been replaced early. Please include a brief explanation for how the customer determined this future replacement date (or, if not known, please explain why this is not known)).

Hahne Hall Dorm was renovated in August 2016. Project scope included upgrade of numerous envelope system (wall insulation and window U-values) as well as building systems (lighting and HVAC).

- Installation of new equipment to replace equipment that needed to be replaced. The customer installed new equipment on the following date(s):
_____.
- Installation of new equipment for new construction or facility expansion. The customer installed new equipment on the following date(s):
_____.
- Behavioral or operational improvement.

B) Energy savings achieved/to be achieved by the energy efficiency program:

- 1) If you checked the box indicating that the project involves the early replacement of fully functioning equipment replaced with new equipment, then calculate the annual savings [(kWh used by the original equipment) - (kWh used by new equipment) = (kWh per year saved)]. Please attach your calculations and record the results below:

Annual savings: 194,144 kWh

Refer to Appendix B for calculations and supporting document

- 2) If you checked the box indicating that the customer installed new equipment to replace equipment that needed to be replaced, then calculate the annual savings [(kWh used by less efficient new equipment) - (kWh used by the higher efficiency new equipment) = (kWh per year saved)]. Please attach your calculations and record the results below:

Annual savings: _____ kWh

Please describe any less efficient new equipment that was rejected in favor

of the more efficient new equipment.

- 3) If you checked the box indicating that the project involves equipment for new construction or facility expansion, then calculate the annual savings [(kWh used by less efficient new equipment) - (kWh used by higher efficiency new equipment) = (kWh per year saved)]. Please attach your calculations and record the results below:

Annual savings: _____kWh

Please describe the less efficient new equipment that was rejected in favor of the more efficient new equipment.

- 4) If you checked the box indicating that the project involves behavioral or operational improvements, provide a description of how the annual savings were determined.

Annual savings: _____kWh

Section 4: Demand Reduction/Demand Response Programs

A) The customer's program involves (check the one that applies):

- Coincident peak-demand savings from the customer's energy efficiency program.**
- Actual peak-demand reduction. (Attach a description and documentation of the peak-demand reduction.)
- Potential peak-demand reduction (check the one that applies):
 - The customer's peak-demand reduction program meets the requirements to be counted as a capacity resource under a tariff of a regional transmission organization (RTO) approved by the Federal Energy Regulatory Commission.
 - The customer's peak-demand reduction program meets the requirements to be counted as a capacity resource under a program that is equivalent to an RTO program, which has been approved by the Public Utilities Commission of Ohio.

B) On what date did the customer initiate its demand reduction program?

Hahne Dorm was upgraded in August 2016.

C) What is the peak demand reduction achieved or capable of being achieved (show calculations through which this was determined):

29.5 kW

Refer to Appendix B for calculations and supporting documentation.

Section 5: Request for Cash Rebate Reasonable Arrangement (Option 1) or Exemption from Rider (Option 2)

Under this section, check the box that applies and fill in all blanks relating to that choice.

Note: If Option 2 is selected, the application will not qualify for the 60-day automatic approval. All applications, however, will be considered on a timely basis by the Commission.

A) The customer is applying for:

Option 1: A cash rebate reasonable arrangement.

OR

Option 2: An exemption from the energy efficiency cost recovery mechanism implemented by the electric utility.

OR

Commitment payment

B) The value of the option that the customer is seeking is:

Option 1: A cash rebate reasonable arrangement, which is the lesser of (show both amounts):

A cash rebate of \$8,751. Refer to Appendix C for documentation. (Rebate shall not exceed 50% project cost.

Option 2: An exemption from payment of the electric utility's energy efficiency/peak demand reduction rider.

An exemption from payment of the electric utility's energy efficiency/peak demand reduction rider for ___ months (not to exceed 24 months). (Attach calculations showing how this time period was determined.)

OR

A commitment payment valued at no more than \$_____. (Attach documentation and

calculations showing how this payment amount was determined.)

OR

- Ongoing exemption from payment of the electric utility's energy efficiency/peak demand reduction rider for an initial period of 24 months because this program is part of the customer's ongoing efficiency program. (Attach documentation that establishes the ongoing nature of the program.) In order to continue the exemption beyond the initial 24 month period, the customer will need to provide a future application establishing additional energy savings and the continuance of the organization's energy efficiency program.)

Section 6: Cost Effectiveness

The program is cost effective because it has a benefit/cost ratio greater than 1 using the (choose which applies):

- Total Resource Cost (TRC) Test. The calculated TRC value is: _____
(Continue to Subsection 1, then skip Subsection 2)
- ✓ Utility Cost Test (UCT) . The calculated UCT value is 12.65 (Skip to Subsection 2.) **Refer to Appendix D for calculations and supporting documents.**

Subsection 1: TRC Test Used (please fill in all blanks).

The TRC value of the program is calculated by dividing the value of our avoided supply costs (generation capacity, energy, and any transmission or distribution) by the sum of our program overhead and installation costs and any incremental measure costs paid by either the customer or the electric utility.

The electric utility's avoided supply costs were _____.

Our program costs were _____.

The incremental measure costs were _____.

Subsection 2: UCT Used (please fill in all blanks).

We calculated the UCT value of our program by dividing the value of our avoided supply costs (capacity and energy) by the costs to our electric utility (including administrative costs and incentives paid or rider exemption costs) to obtain our commitment.

Our avoided supply costs were \$143,365.

The utility's program costs were \$2,578.

The utility's incentive costs/rebate costs were \$8,751.

Refer to Appendix D for calculations and supporting documents.

Section 7: Additional Information

Please attach the following supporting documentation to this application:

Narrative description of the program including, but not limited to, make, model, and year of any installed and replaced equipment.

A copy of the formal declaration or agreement that commits the program or measure to the electric utility, including:

- 1) any confidentiality requirements associated with the agreement;
- 2) a description of any consequences of noncompliance with the terms of the commitment;
- 3) a description of coordination requirements between the customer and the electric utility with regard to peak demand reduction;
- 4) permission by the customer to the electric utility and Commission staff and consultants to measure and verify energy savings and/or peak-demand reductions resulting from your program; and,
- 5) a commitment by the customer to provide an annual report on your energy savings and electric utility peak-demand reductions achieved.

Refer to Offer Letter following this application

A description of all methodologies, protocols, and practices used or proposed to be used in measuring and verifying program results. Additionally, identify and explain all deviations from any program measurement and verification guidelines that may be published by the Commission.

19500677 01		
MIAMI UNIVERSITY		
4955 OXFORD TRENTON RD		
OXFORD, OH 45056		
Date	Days	Actual KWH
7/29/2016	29	7,105,788
6/30/2016	30	7,389,036
5/31/2016	32	6,726,816
4/29/2016	29	6,904,512
3/31/2016	31	6,879,096
2/29/2016	31	7,505,820
1/29/2016	29	6,214,032
12/31/2015	31	6,307,524
11/30/2015	31	6,942,348
10/30/2015	30	7,230,744
9/30/2015	30	8,264,736
8/31/2015	31	7,996,896
Total		85,467,348

Appendix C - Cash Rebate Calculation

Miami University Hahne Hall Upgrade

Measure	Quantity	Cash Rebate Rate	Cash Rebate
Hahne Hall Upgrade	1	50% of incentive that would be offered by the Smart Saver Custom program	\$8,751
			\$8,751

Appendix D -UCT Value

Miami University Hahne Hall Renovation

Measure	Total Avoided Cost	Program Cost	Incentive	Quantity	Measure UCT
Hahne Hall Building Upgrade	\$143,365	\$2,578	\$8,751	1	12.65
Totals	\$143,365	\$2,578	\$8,751	1	

Total Avoided Supply Costs	\$143,365	<i>Aggregate Application UCT</i>	12.65
Total Program Costs	\$2,578		
Total Incentive	\$8,751		

**Mercantile Self Direct
Nonresidential Custom Rebate Application
PART 1**



Ohio Mercantile Self Direct Program

Application Guide & Cover Sheet

Questions? Call 1-866-380-9580 or visit www.duke-energy.com.

Email this form along with completed Mercantile Self Direct Prescriptive or Custom applications, proof of payment, energy savings calculations and spec sheets to SelfDirect@Duke-Energy.com. You may also fax to 1-513-629-5572.

Mercantile customers, defined as using at least 700,000 kWh annually or having an account in multiple locations are eligible for the Mercantile Self Direct program. Indicate which applies:

- a single Duke Energy Ohio account with 700,000 kWh annual usage
- an account with multiple locations

Please list Duke Energy account numbers below (attach listing of multiple accounts and/or billing history for other utilities as required):

Account Number	Annual Usage	Account Number	Annual Usage
1950-0677-01-8	85,000,000		

Self Direct rebates are available for completed Custom projects that have not previously received a Duke Energy Smart \$aver® Custom Incentive. Self Direct rebates are applicable to Prescriptive measures that were installed more than 90 days prior to submission to Duke Energy and have not previously received a Duke Energy Prescriptive rebate.

Self Direct Program rules allow for, though do not require, certain projects that are Prescriptive in nature under the Smart \$aver program to be evaluated using the Custom process in the Self Direct program. Use the list on page two as a guide to determine which Self Direct program best fits your project(s). Apply for Self Direct projects using the appropriate application forms in conjunction with this cover sheet.

Self Direct Program rules also allow for behaviorally based and/or no cost and low cost projects to receive rebates.

Please check each box to indicate completion/inclusion of the following program requirements:

<input type="checkbox"/> All sections of appropriate application(s) are completed	<input type="checkbox"/> Proof of payment.*	<input type="checkbox"/> Manufacturer's Spec sheets	<input type="checkbox"/> Energy model/calculations and detailed inputs for Custom applications
---	---	---	--

*If a single payment record is intended to demonstrate the costs of both Prescriptive & Custom projects, please include an additional document with an estimated breakout of costs for each Prescriptive and Custom energy conservation measure.

**Behavioral energy efficiency and demand reduction projects must be both measurable and verifiable. Provide justification with your application. Rebates for such projects may be small in magnitude.

**Mercantile Self Direct
Nonresidential Custom Rebate Application
PART 1**



Application Type	Prescriptive Measures with Optional Custom Processing	
Heating & Cooling and Window Films, Programmable Thermostats, & Guest Room Energy Management Systems	<input type="checkbox"/> Energy Star Window/Sleeve/Room AC <input type="checkbox"/> Central Air Unit	<input type="checkbox"/> Air Source Heat Pump Water Heater
	<input type="checkbox"/> Setback/Programmable Thermostat <input type="checkbox"/> Guestroom Energy Management Control	<input type="checkbox"/> Window Film
Chillers	<input type="checkbox"/> Air Cooled Chiller	<input type="checkbox"/> Water Cooled Chiller
Motors, Pumps and Variable Frequency Drives (VFDs)	<input type="checkbox"/> VFD – Applied to Process Pump <input type="checkbox"/> VFD – Applied to HVAC Pump	<input type="checkbox"/> VFD – applied to HVAC Fan
Food Service	<input type="checkbox"/> ENERGY STAR Hot Food Holding Cabinet <input type="checkbox"/> Night Covers for Display <input type="checkbox"/> ECM Cooler, Freezer, and Display Case Motors <input type="checkbox"/> ENERGY STAR Solid or Glass Door Reach-in Freezer or Refrigerator	<input type="checkbox"/> Anti-Sweat Heater Control <input type="checkbox"/> Cooking Equipment <input type="checkbox"/> ENERGY STAR ICE MACHINE
Process Equipment	<input type="checkbox"/> Engineered Nozzle – COMPRESSED AIR <input type="checkbox"/> Air compressor equipped with VFD	<input type="checkbox"/> Pellet Dryer Duct Insulation
Chiller Tune-ups	<input type="checkbox"/> Air cooled chiller tune-up	<input type="checkbox"/> Water cooled chiller tune-up

Please indicate above any Prescriptive energy conservation measures to be evaluated through the Custom process. Only Prescriptive measures listed above are eligible for this option. To receive a Self Direct Custom rebate, a detailed analysis of pre-project and post-project energy usage and project costs must be included in the application.

Although some Self Direct Prescriptive measures are eligible for evaluation through Custom processes, such an approach may not be most effective for certain measures.

Mercantile Self Direct Nonresidential Custom Rebate Application PART 1



Proposed energy efficiency measures may be eligible for Self-Direct Custom rebates if they clearly reduce electrical consumption and/or demand as compared to the appropriate baseline.

Before you complete this application, please note the following important criteria:

- Submitting this application does not guarantee a rebate will be approved.
- Rebates are based on electricity conservation only.
- Electric demand and/or energy reductions must be well documented with auditable calculations.
- Incomplete applications cannot be reviewed; all fields are required.

Refer to the complete list of Instructions and Disclaimers, beginning on page 6.

Notes on the Application Process

If you have any questions concerning how to complete any portion of the application or what supplementary information is required, please contact your Duke Energy Ohio, Inc account manager or the Duke Energy Self Direct team at 1-866-380-9580.

Every application must include calculations of the baseline electrical usage and the electrical usage of the proposed high-efficiency equipment/system. These calculations are performed and submitted by the Duke Energy Ohio customer, or your designated equipment vendor / engineer. Application Part 2 worksheets and page 6 of this application contain additional guidance on acceptable calculations. *Complex or unique projects may require the use, at the applicant's expense, of modeling software.* Please contact the Duke Energy Self Direct team with questions about these requirements.

If you do not receive an acknowledgement email within 1 day of submitting an application via online, email, or fax, please call 1-866-380-9580. The acknowledgement email will provide with an estimated response time based on an initial assessment of your application. The application review may include some communication to resolve any questions about the project or to request additional information. Applications that are received complete without missing information have a faster review time.

There are two ways to submit your completed application form and excel worksheets.

Email: Complete, sign, scan and send this application form and attachments to:
SelfDirect@duke-energy.com (Note attachment size limit is applicable)

Fax: 513-629-5572

**Mercantile Self Direct
Nonresidential Custom Rebate Application
PART 1**



1. Contact Information (Required)

Duke Energy Customer Contact Information					
Company Name	Miami University - Accounts Payable				
Address	Roudebush RM 107				
City	Oxford	State	OH	Zip Code	43056
Project Contact					
Title	Mr. Doug Hammerle				
Office Phone	513-529-1696	Mobile Phone		Fax	513-529-2482
E-mail Address	hammerd@miamioh.edu				

Equipment Vendor / Contractor / Architect / Engineer Contact Information					
Company Name	Prater Engeering Associates, Inc.				
Address	6130 Wilcox Rd				
City	Dublin	State	OH	Zip Code	43016
Project Contact	<input checked="" type="checkbox"/> Mr. <input type="checkbox"/> Ms	Chris Whicker			
Title	Mechanical Engineer				
Office Phone	614-766-4896	Mobile Phone		Fax	614-766-2354
E-mail Address	cwhicker@praterengr.com				

Who is the primary point of contact for technical questions? ¹	Chris Whicker
---	---------------

Payment Information	
If an incentive is awarded, who should receive payment? ²	
<input checked="" type="checkbox"/> Customer <input type="checkbox"/> Vendor (customer or customer's agent ³ must sign below)	
I hereby authorize payment of incentive directly to the vendor:	
Customer Signature _____	Date ____ / ____ / ____ (mm/dd/yyyy)
Tax ID Number for Payee (provide W-9)	31-6402089
Mailing Address for Payee (if different from above)	
Street	
City	State Zip Code

¹ Note that if the vendor is the primary point of contact, the customer will still be copied on all application correspondence. If the customer does not wish to be copied, the customer must provide a signed waiver indicating an entity acting as agent for the customer. Duke Energy does not act as agent.

² If payment is to be made to an entity other than the Duke Energy account holder or the vendor, a payment waiver is required and will be provided for customer signature.

³ If an outside agent is acting on behalf of the Duke Energy customer of record, a letter of authorization on customer letterhead and signed by an authorized employee of the customer must be provided.

**Mercantile Self Direct
Nonresidential Custom Rebate Application
PART 1**



2. Project Information (Required)

- A. Please indicate project type:
- New Construction
 - Expansion at an existing facility (existing Duke Energy account number)
 - Replacing equipment due to equipment failure
 - Replacing equipment that is estimated to have remaining useful life of 2 years or less
 - Replacing equipment that is estimated to have remaining useful life of more than 2 years
 - Behavioral, operational and/or procedural programs/projects
- B. Please describe your project, or attach a detailed project description that describes the project.
See attached for project description
- C. When did you start and complete implementation?
Start date 03/2015 (mm/yyyy) End date 08/2016 (mm/yyyy)
- D. Are you also applying for Self-Direct Prescriptive rebates and, if so, which one(s)⁴?
Not at this time
- E. Please indicate which worksheet(s) you are submitting for this application (check all that apply):
- Lighting
 - Variable Frequency Drive (VFD)
 - Compressed Air
 - Energy Management System (EMS)
 - General (for projects not easily submitted using one of the above worksheets)
- F. List all assumptions about the baseline and proposed equipment energy use and operation schedule, or attach a document listing that information. Attach specification sheets for all proposed new equipment. See attached for utilization schedule and cut sheets.
- G. Attach a supplier or contractor estimate, engineer's cost estimate, and/or other equivalent information documenting the Implementation Cost for each project listed in your application. Does the Implementation Cost include any internal labor⁵? No.
If yes, please specify which costs are internal labor. N/A

⁴ If your project involves some equipment that is eligible for prescriptive rebates and some equipment that is likely eligible for custom rebates, and if it is feasible to separate the equipment for the energy analysis, then the equipment will be evaluated separately. If it is not feasible to separate the equipment for analysis, then the equipment will be evaluated together in the custom application.

⁵ Internal labor costs cannot be counted in the Incremental Project Cost for purposes of analysis.

**Mercantile Self Direct
Nonresidential Custom Rebate Application
PART 1**



3. Signature

(Required – must be signed by Duke Energy customer)

Customer Consent to Release of Personal Information

I, (insert name) Doug Hammerle, do hereby consent to Duke Energy disclosing my Duke Energy Ohio, Inc Account Number and Federal Tax ID Number to its subcontractors solely for the purpose of administering Duke Energy Ohio's Mercantile Self-Direct Program. I understand that such subcontractors are contractually bound to otherwise maintain my Duke Energy Ohio, Inc Account Number and Federal Tax ID Number in the strictest of confidence.

I realize that under the rules and regulations of the public utilities commission, I may refuse to allow Duke Energy Ohio, Inc to release the information set forth above. By my signature, I freely give Duke Energy Ohio, Inc permission to release the information designated above.

Application Signature

I certify that I meet the eligibility requirements of the Duke Energy Ohio, Inc Mercantile Self Direct Custom Rebates Program and that all information provided within this application is correct to the best of my knowledge. I agree to the terms and conditions set forth for this program. I certify that the numbers, energy savings, and responses shown on this form are correct. Further, I certify that the taxpayer identification number is current and correct. I am not subject to backup withholding because: (a) I am exempt from backup withholding; or (b) I have not been notified by the IRS that I am subject to backup withholding as a result of a failure to report all interest or dividends; or (c) the IRS has notified me that I am no longer subject to backup withholding. I am a U.S. citizen (includes a U.S. resident alien).

Duke Energy Ohio, Inc Customer Signature

Print Name Doug Hammerle

Date 8/22/16



The General Worksheet is part 2 of the application. Do not submit this file without submitting a completed Part1 Custom Application document file, which can be found at www.duke-energy.com. This worksheet is for all projects that are not easily submitted through one of the other worksheets

Before you complete this application, please note the following important criteria:

- Submitting this application does not guarantee an rebate will be approved.
- Rebates already decided to proceed.
- Electric demand and/or energy reductions must be well documented with auditable calculations.
- Incomplete applications will not be reviewed; all fields are required.

Refer to the complete list of Instructions and Disclaimers, found in the Mercantile Self Direct Custom Application Part 1 document.

Please enter your information and data into the cells that are shaded.
Cells in white are locked and cannot be written over.

Duke Energy Customer Contact Information (Match the information in Application Part 1):

Name	Doug Hammerle (Director of Energy Systems)
Company	Miami University (Office Phone: 513-529-1696)

Equipment Vendor / Project Engineer Contact Information

Name	Chris Whicker
Company	Prater Engineering Associates, Inc.

Before proceeding with the custom application, please verify that your project is not on the Self-Direct Prescriptive application.

The prescriptive rebate applications can be found at:

<http://www.duke-energy.com/ohio-large-business/smart-saver/mercantile-self-direct.asp>

Prescriptive rebate amounts are pre-approved.



List of Sites (Required)

App No.	
Rev.	

Provide a list of sites addressed by this custom rebate application

Site ID (see note 1)	Duke Energy Electric Account Number(s) (see note 2)	Facility Address	List of Proposed Projects at each site	Annual Hours of Operation	Gross Square Footage	Conditioned Square Footage	Facility Age (years)
225	12345678 01	Example: 123 Main Street, Anywhere USA 12345	Project Name(s)	5,840	42,000	38,000	12
	#1950-0677-01-8	5357 Bonham Road, Oxford, OH 45056	Building Renovation	8,760	76,116	76,116	49
	Information from Page 3 of 3 (included due to format issues)	Describe the Baseline Equipment/System Building is served off of the campus chilled water and campus hot water system. Per ASHRAE Appendix G and LEED Modeling guidelines, the baseline system for non-residential is System 7 (Packaged rooftop unit with reheat using chilled water and hot water). Residential System 1 is used utilizing chilled water and hot water.	←				
	Information from Page 3 of 3 (included due to format issues)	Energy Savings (Proposed) Proposed Annual Electric Energy = 1,187,729.126 kWh (protected form is depicting this information as "#####")	←				

1 Site ID

Can be a store number, building name or other way to identify the location. If there is only one site involved in this application, then a Site ID is not necessary

2 Account Numbers

Must match the facility of the proposed project(s). If there are multiple meters at a site, only include the meters that pertain to the project(s).



For each project, answer the following questions (use one worksheet per project)

App No.	0
Rev.	0

Project Name: Miami University North Quad Project (Mahne Hall)

How would you classify this project? (Place an x in all boxes that apply)

Lighting	<input checked="" type="checkbox"/>	Heating/Cooling	<input checked="" type="checkbox"/>	Air Compressor	<input checked="" type="checkbox"/>	Energy Management System	<input checked="" type="checkbox"/>
VFD		Motors/Pumps	<input checked="" type="checkbox"/>	Process Equipment		Other, describe below:	<input checked="" type="checkbox"/>
							Total building remodel

Brief Project Description

Describe the Baseline (see note 3) Equipment/System	Describe the Proposed High Efficiency Project
See adjacent text.	

If Existing Equipment is the Baseline, how many years of useful life remain or how many years until scheduled replacement? N/A

Detailed Project Description Attached? Yes (Required)

Operating Hours (see note 4)

24 x 7	Weekday		Saturday		Sunday		Weeks of Use in Year (see note 5)	Total Annual Hours of Use
	Start Hour	End Hour	Start Hour	End Hour	Start Hour	End Hour		
Yes							52	8,760

Energy Savings

	Baseline (see Note 3)	Proposed	Savings	Describe how energy numbers were calculated
Annual Electric Energy	1,457,141 kWh	#####	165,592 kWh	
Electric Demand	384 kW	334 kW	49 kW	
Calculations attached	Yes	Yes	(Required)	

TRACE 700

Simple Payback

Average electric rate (\$/kWh) on the applicable accounts (see note 6)	\$0.10
Estimated annual electric savings	\$16,559
Other annual savings in addition to electric savings, such as operations, maintenance, other fuels	\$32,263.00
Incremental cost to implement the project (equipment & installation) (see note 7)	\$983,449.00
Copy of vendor proposal is attached (see note 8)	Yes
Simple Electric Payback In years (see note 9)	59.39005634
Total Payback in years	20.14349941

1 Baseline

Retrofit projects: the existing equipment is the baseline.

New construction projects: the baseline is the standard option in today's market, taking into account any applicable organizational, local, state or federal codes or standards currently in effect.

4 Operating Hours

Describe when the equipment is typically used. If the project is proposed for more than one site, provide any variations in operating hours between the sites on a separate sheet.

5 Weeks of Use in Year

If the equipment is not in use 52 weeks during the year (for example, during holiday or summer break), provide an explanation of when usage is not expected and why:

6 Average electric rate (\$/kWh)

If you do not know your average electric rate, use \$0.10/kWh.

7 Incremental cost to implement the project

Costs exclude self installation costs. Retrofit projects, incremental cost is the total cost of the proposed project. New construction or where the existing equipment must be replaced anyway, then incremental cost is the premium of the proposed high efficiency project over baseline.

8 Copy of vendor invoice is attached

Vendor invoices detailing costs of the project are always required.

New construction projects or where the existing equipment must be replaced anyway, vendor proposal of baseline must also be attached.

9 Simple Electric Payback

If the simple electric payback is less than 1 year, the rebate structure is affected. Double check average electric rate for correct payback.



Smart Saver® Incentive Program

phone: 866.380.9580

fax: 980.373.9755

customprocessing@duke-energy-energyefficiency.com

12/1/2016

Doug Hammerle
MIAMI UNIVERSITY - 1950067701
4955 OXFORD TRENTON RD
OXFORD OH 45056

Subject: Your Application for a Duke Energy Mercantile Self-Direct Rebate CMO16-0000097766

Dear Doug Hammerle,

Thank you for your Duke Energy Mercantile Self Direct rebate application. As noted in the Energy Conservation Measure (ECM) chart on page 2, a total rebate of \$8,751.00 has been proposed for your project completed in the 2016 calendar years. **All Self Direct Rebates are contingent upon approval by the Public Utilities Commission of Ohio (PUCO).**

At your earliest convenience, please indicate if you accept this rebate by:

- providing your signature on Page 2
- completing the PUCO-required affidavit on Page 3

Please return the documents to my attention via fax at 513.629.5572 or email to customprocessing@duke-energy-energyefficiency.com. Upon receipt, Duke Energy will submit the necessary documentation to PUCO. Following PUCO's approval, Duke Energy will remit payment.

We value your business and look forward to working with you on this and future energy efficiency projects. We hope you will consider our Smart Saver® incentives, when applicable. Please contact me if you have any questions.

Sincerely,

A handwritten signature in black ink, appearing to read 'Andrew Taylor', with a long horizontal flourish extending to the right.

Andrew Taylor
Program Manager
Custom Incentives

cc: Deanna Bowden
Chris Whicker



**Please indicate your response to this rebate offer
within 30 days of receipt.**

Rebate is accepted.

Rebate is declined.

By accepting this rebate, MIAMI UNIVERSITY - 1950067701 affirms its intention to commit and integrate the energy efficiency projects listed on the following pages into Duke Energy's peak demand reduction, demand response and/or energy efficiency programs.

Additionally, MIAMI UNIVERSITY - 1950067701 also agrees to serve as joint applicant in any future filings necessary to secure approval of this arrangement as required by PUCO and to comply with any information and reporting requirements imposed by rule or as part of that approval.

Finally, MIAMI UNIVERSITY - 1950067701 affirms that all application information submitted to Duke Energy pursuant to this rebate offer is true and accurate. Information in question would include, but not be limited to, project scope, equipment specifications, equipment operational details, project costs, project completion dates, and the quantity of energy conservation measures installed.

If rebate is accepted, will you use the monies to fund future energy efficiency and/or demand reduction projects? Yes No

Customer Signature

Printed Name

Date



Proposed Rebate Amounts

Measure ID	Energy Conservation Measure	Proposed Rebate Amount
ECM-1	Hahne Hall Dorm Renovation	\$8,751.00 per project X 1
	Total	\$8,751.00



**Application to Commit
Energy Efficiency/Peak Demand Reduction Programs**

Case No.: ____ - ____ -EL-EEC

State of _____ :

_____, Affiant, being duly sworn according to law, deposes and says that:

1. I am the duly authorized representative of:

[INSERT CUSTOMER OR EDU COMPANY NAME AND ANY APPLICABLE NAME(S) DOING BUSINESS AS]

2. I have personally examined all the information contained in the foregoing application, including any exhibits and attachments. Based upon my examination and inquiry of those persons immediately responsible for obtaining the information contained in the application, I believe that the information is true, accurate and complete.

3. I am aware of fines and penalties which may be imposed under Ohio Revised Code Sections 2921.11, 2921.31, 4903.02, 4903.03, and 4903.99 for submitting false information.

SIGNATURE OF AFFIANT & TITLE

Sworn and subscribed before me this ____ day of _____, _____
DAY MONTH YEAR

SIGNATURE OF OFFICIAL ADMINISTERING OATH

PRINT NAME AND TITLE

My commission expires on _____
DATE



Smart Saver[®] Incentive Program

phone 866.380.9580

fax 980.373.9755

customprocessing@duke-energy-energyefficiency.com

12/1/2016

Doug Hammerle
MIAMI UNIVERSITY - 1950067701
4955 OXFORD TRENTON RD
OXFORD OH 45056

Subject: Your Application for a Duke Energy Mercantile Self-Direct Rebate CMO16-0000097766

Dear Doug Hammerle,

Thank you for your Duke Energy Mercantile Self Direct rebate application. As noted in the Energy Conservation Measure (ECM) chart on page 2, a total rebate of \$8,751.00 has been proposed for your project completed in the 2016 calendar years. All Self Direct Rebates are contingent upon approval by the Public Utilities Commission of Ohio (PUCO).

At your earliest convenience, please indicate if you accept this rebate by:

- providing your signature on Page 2
- completing the PUCO-required affidavit on Page 3

Please return the documents to my attention via fax at 513.629.5572 or email to customprocessing@duke-energy-energyefficiency.com. Upon receipt, Duke Energy will submit the necessary documentation to PUCO. Following PUCO's approval, Duke Energy will remit payment.

We value your business and look forward to working with you on this and future energy efficiency projects. We hope you will consider our Smart Saver[®] incentives, when applicable. Please contact me if you have any questions.

Sincerely,

A handwritten signature in black ink, appearing to read 'Andrew Taylor', with a horizontal line extending to the right.

Andrew Taylor
Program Manager
Custom Incentives

cc: Deanna Bowden
Chris Whicker



**Please indicate your response to this rebate offer
within 30 days of receipt.**

Rebate is accepted.

Rebate is declined.

By accepting this rebate, MIAMI UNIVERSITY - 1950067701 affirms its intention to commit and integrate the energy efficiency projects listed on the following pages into Duke Energy's peak demand reduction, demand response and/or energy efficiency programs.

Additionally, MIAMI UNIVERSITY - 1950067701 also agrees to serve as joint applicant in any future filings necessary to secure approval of this arrangement as required by PUCO and to comply with any information and reporting requirements imposed by rule or as part of that approval.

Finally, MIAMI UNIVERSITY - 1950067701 affirms that all application information submitted to Duke Energy pursuant to this rebate offer is true and accurate. Information in question would include, but not be limited to, project scope, equipment specifications, equipment operational details, project costs, project completion dates, and the quantity of energy conservation measures installed.

If rebate is accepted, will you use the monies to fund future energy efficiency and/or demand reduction projects? Yes No

Customer Signature

Printed Name

Date



Proposed Rebate Amounts

Measure ID	Energy Conservation Measure	Proposed Rebate Amount
ECM-1	Hahne Hall Dorm Renovation	\$8,751.00 per project X 1
	Total	\$8,751.00



Public Utilities Commission

(Mercantile Customers Only)

Application to Commit Energy Efficiency/Peak Demand Reduction Programs

Case No.: ___-___-EL-EEC

17-0164EL-EEC

State of OHIO :

Doug Hammerle, Affiant, being duly sworn according to law, deposes and says that:

1. I am the duly authorized representative of:

Miami University

[INSERT CUSTOMER OR EDU COMPANY NAME AND ANY APPLICABLE NAME(S) DOING BUSINESS AS]

2. I have personally examined all the information contained in the foregoing application, including any exhibits and attachments. Based upon my examination and inquiry of those persons immediately responsible for obtaining the information contained in the application, I believe that the information is true, accurate and complete.

3. I am aware of fines and penalties which may be imposed under Ohio Revised Code Sections 2921.11, 2921.31, 4903.02, 4903.03, and 4903.99 for submitting false information.

Doug Hammerle Dir. of Energy Systems

SIGNATURE OF AFFIANT & TITLE

Sworn and subscribed before me this 7th day of DECEMBER, 2016
DAY MONTH YEAR

Scott W. Lessing
SIGNATURE OF OFFICIAL ADMINISTERING OATH NAME AND TITLE

My commission expires on _____
DATE



Item 2B – Project Description

This renovation project includes renovation of all dormitory living spaces, common areas, and recreation areas. The project includes elevator upgrades and a new sprinkler system will be installed throughout the building. An upgraded HVAC system will be installed throughout the building. The new HVAC system will use hydronic heating and cooling. Chilled water and heating hot water will be provided via the campus systems. Hydronic water (HWS/R & CHWS/R) will be distributed throughout the building via new end-suction pumps that will utilize variable frequency drives. A new air handler (AHU-1) will be located in the lower level. This air handler will serve VAV boxes, which will provide reheat capability. A DOAS unit(s) will be located in the attic to provide ventilation air to restroom groups, 2nd/3rd floor common areas, and corridors. Conditioning of restroom groups will be achieved by blower coil units (BCU's) located in the attic. BCU's contain hot water and chilled water coils. The DOAS unit will have heat recovery capability (sensible-only heat wheels). DOAS-1 will recover heat from the associated restroom groups.

The existing primary electrical service will be upgraded from 4.16 kV to 12.47 kV. A new unit substation will be provided, which will be served from a 15kV pad mounted switch. Existing 15 kV conductors currently connected to the 5 kV equipment will be relocated and extended to a new 300 kVA transformer in the unit substation with a 12,470V primary and a 208/120V, 3 phase, 4 wire secondary. Power will be distributed from the unit substation switchboard to a distribution switchboard, lighting and power panelboards, and HVAC equipment. Additional panelboards and HVAC equipment will be fed from the second switchboard.

LED lighting will be used in majority of spaces. Fluorescent fixtures to be used in equipment room, utility and attic space. Lighting system is served at 120 volts. Vacancy sensors and manual switches will be provided in standalone spaces throughout the building to automatically shut off lighting when the area is unoccupied. Vacancy sensors require lighting to be manually turned on when an occupant enters the space. Lighting in corridors and common areas will be controlled by the building automation system to automatically lower lighting levels at designated times. Select lighting fixtures in corridors, restrooms, service spaces and other areas dictated by the design will operate as nightlights and emergency lighting fixtures, and will not be switched.

NOTES:

1. OTHER LAMPING & FINISHES AVAILABLE
2. MOUNTS TO STANDARD 4" J-BOX (BY OTHERS)
3. INTEGRAL ELECTRONIC LED MODULES & DRIVERS

CHANGES				NOTES
REV	BY	APP	DATE	
	RL	JJ	1-08-14	INITIAL RELEASE

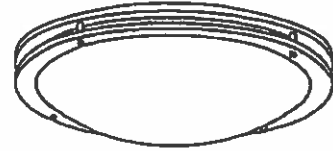

ISOMETRIC VIEW
NO SCALE

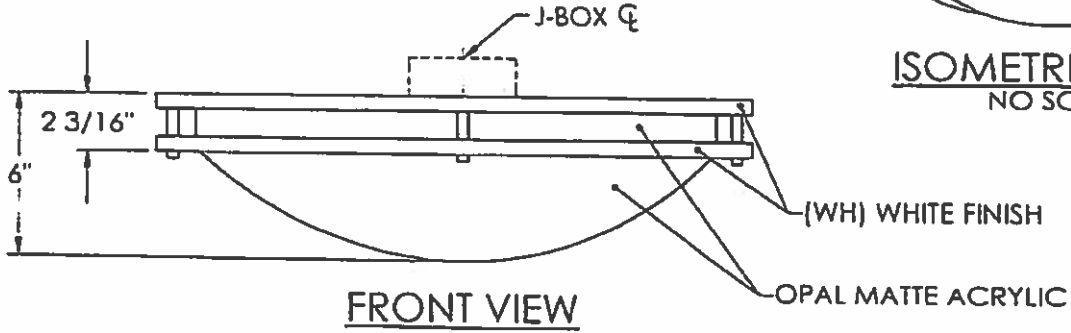

FRONT VIEW

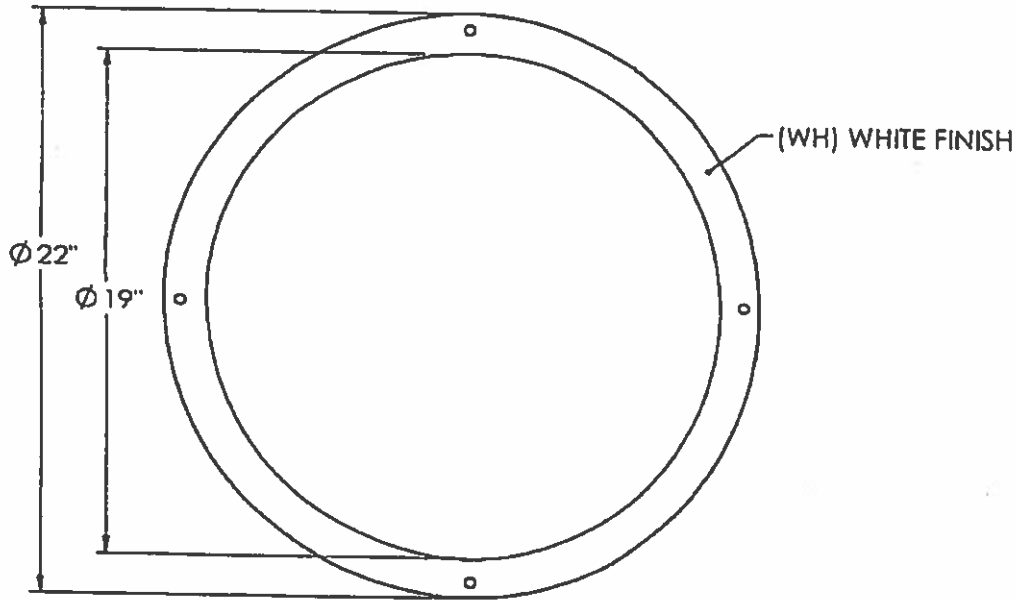

BOTTOM VIEW

U.L./C.U.L. LISTED
LUMINAIRE



ITEM NUMBER			
LAMPING LED, 56 WATT, 4000K		TYPE	WEIGHT
FINISH (WH) WHITE		VOLTAGE 120/277	SCALE N/A
COMMENTS M1 = UNIVERSITY OF MIAMI LED VERSION, 2 CIRCUIT		DATE 7/1/15	DWG NUMBER
APP BY JJ	DRAWN BY RL	REVISION	



Project 15-20238-4
MIAMI UNIVERSITY HAHNE HALL

Submitted By
KING LIGHTING INC

Catalog Number
UNS 2 32 120 GEB10PS WGCUN NST / HC36

Notes

Type

C1



FEATURES & SPECIFICATIONS

INTENDED USE — Ideal for applications requiring high brightness and high illumination levels such as retail, industrial and warehouse areas.

CONSTRUCTION — Fixture is assembled with snap and screwed together components. Available in a variety of lengths and lamp configurations. Gripper-back design feature adds superior strength and rigidity.

Channel is made of heavy-duty, 20-gauge, cold-rolled steel. Channel cover is secured with quarter-turn fasteners for tool-less access to wireway. Endplates attach with screws.

Finish: High-gloss baked white polyester. Five-stage iron-phosphate pretreatment ensures superior paint adhesion and rust resistance.

ELECTRICAL — Thermally protected, resetting, Class P, HPF UL listed, CSA certified ballast is standard. Electronic ballasts are sound rated A. AWM, TFN or THHN wire used throughout, rated for required temperatures.

INSTALLATION — Fixture may be suspended or surface mounted, as a unit or continuous row installation. Channel connector comes standard.

LISTINGS — UL Listed for 25°C ambient temperatures and damp locations. Optional NOM certification (meets Mexican standards) is available.

WARRANTY — 1-year limited warranty. Complete warranty terms located at www.acuitybrands.com/CustomResources/Terms_and_conditions.aspx.

Note: Specifications subject to change without notice.

Actual performance may differ as a result of end-user environment and application.

Low Bay Industrial



UNS

2', 3', 4' or 8' lengths
T8, T5HO and T8 lamps
1, 2 or 3 lamps

Specifications

Length:	24 (61.0)
	36 (91.4)
	48 (121.9)
	96 (243.8)
Width:	4-3/8 (11.1)
Depth:	3 (76)

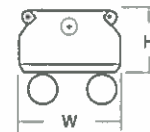

All dimensions are inches (centimeters) unless otherwise noted.

ORDERING INFORMATION For shortest lead times, configure products using standard options (shown in bold).

Example: UNS 2 32 MVOLT GEB10IS

UNS	2	32	120		GEB10PS	
Series	Number of lamps	Lamp type	Voltage	Ballast configuration	Options	
UNS For tandem double length unit, add prefix 1. Example: TUNS	1 2	T8 lamps 17 17W (24") 25 25W (36") 32 32W (48") Slimline lamps 48T8 38W (48") 48T8HO 60W (48") 96T8 59W (96") 96T8HO 86W (96")	T5 lamps 14T5 14W (22") 21T5 21W (34") 28T5 28W (46") T5HO lamps 24T5HO 24W (22") 39T5HO 39W (34") 54T5HO 54W (46")	MVOLT HVOLT 120 277 347	(blank) All one or two lamp ballasts 1/3 One three lamp ballast 1/4 One four lamp ballast 2/3 Two three lamp ballasts 1/4/2 One four lamp and one two lamp ballasts	Shipped installed in fixture GEB10IS T8 electronic ballast, <10% THD, instant start GEB10ISH T8 electronic ballast, <10% THD, high BF, instant start GEB10PS Electronic ballast, <10% THD, program start GEB10RS Electronic ballast, <10% THD, rapid start ¹ EL Emergency battery pack ^{1,2} GLR Internal fast-blow fuse ³ GMF Internal slow-blow fuse ³ PLR Plug-in wiring TILW Tandem in-line wiring ⁴ NOM NOM Certified

WGCUN NST / H36

Accessories: Order as separate catalog number.

SQ_	Swivel stem hanger (specify length in 2" increments)
1B	Ceiling spacer (1-1/2" to 2-1/2" from ceiling)
HC36	Chain hangers (1 pair, 36" long)
THUN	Tong Hanger
HRUNS1	Hooker™ T-bar hanger (1-1/2" from ceiling)
WGCUN NST	4" white wireguard (order two for 8' fixtures)

Notes

- 347 volt.
- Consult www.lithonia.com or our Product Selection Guide for additional models.
- Must specify voltage.
- Not available for fixtures with 1-lamp cross-section.



Project 15-20238-4
MIAMI UNIVERSITY HAHNE HALL

Submitted By
KING LIGHTING INC

Catalog Number
UNS 2 32 120 GEB10PS WGCUN NST / HC36

Notes

Type

C1

UNS Low Bay Industrials

MOUNTING DATA

For unit or row installation, surface or suspended mounting. Use hanger appropriate for fixture width.

Unit Installation — Minimum of two hangers required.

Row Installation — One hanger per channel plus one per row required.

Hooker™ (HRUNS1), HC36 and THUN Hangers — Minimum two per channel (unit and row).

See ACCESSORIES below for hanging devices.

DIMENSIONS

Inches (millimeters). Subject to change without notice.

A = 11/16 (18) Dia. K.O.
B = 7/8 (22) Dia. K.O.
C = 2 (51) Dia. K.O.

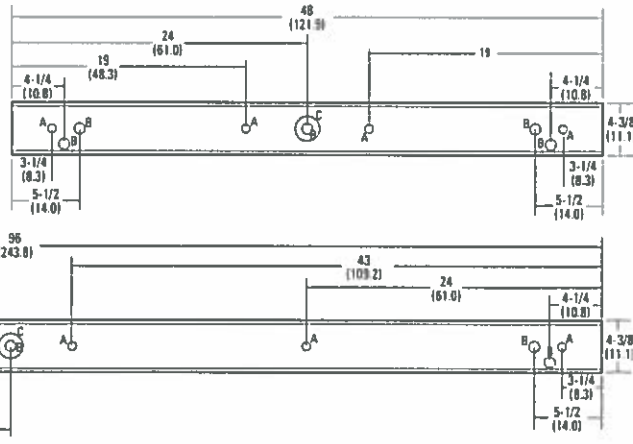
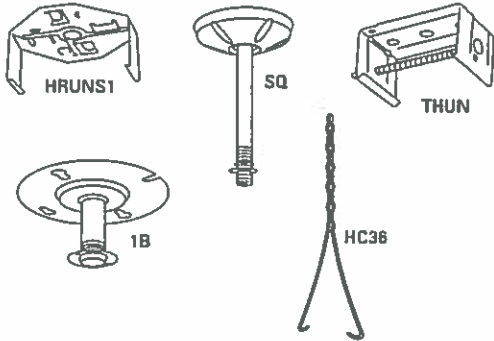
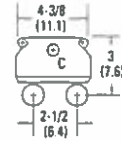

PHOTOMETRICS

Calculated using the zonal cavity method in accordance with IESNA LM41 procedure. Floor reflectances are 20%. Lamp configurations shown (2 54T5HO) are typical. All data based on 25°C. Full photometric data on these and other configurations available upon request.

UNS 2 32

Report: LTL12571
LUMENS PER LAMP 2900
Luminaire Efficiency: 92.8%

Coefficients of Utilization

pc	Coefficients of Utilization								
	80%			20%			30%		
	70%	50%	30%	50%	30%	10%	50%	30%	10%
0	106	106	106	93	93	93	86	86	86
1	94	89	84	78	74	71	71	68	66
2	84	76	68	66	61	56	60	56	52
3	76	65	57	57	51	45	52	47	42
4	69	57	48	50	43	38	46	40	35
5	63	51	42	44	37	32	41	35	30
6	58	45	36	40	33	28	37	31	26
7	54	41	32	36	29	24	33	27	23
8	50	37	29	33	26	21	30	24	20
9	46	34	26	30	23	19	28	22	18
10	43	31	23	28	21	17	26	20	16

Zonal Lumen Summary

Zone	Lumens	% Lamp	% Fixture
0° - 30°	842	14.5	15.6
0° - 40°	1436	24.8	26.7
0° - 60°	2810	48.4	52.2
0° - 90°	4363	75.2	81.0
90° - 180°	1021	17.6	19.0
0° - 180°	5384	92.8	100.0

UNS 1 32

Report: LTL12570
LUMENS PER LAMP 3050
Luminaire Efficiency: 93.3%

Coefficients of Utilization

pc	Coefficients of Utilization								
	80%			20%			30%		
	70%	50%	30%	50%	30%	10%	50%	30%	10%
0	108	108	108	95	95	95	88	88	88
1	94	89	83	78	74	71	72	69	66
2	85	75	68	66	61	56	61	56	52
3	76	65	56	57	51	45	53	47	42
4	69	57	48	50	43	38	46	40	35
5	63	50	41	45	37	32	41	35	30
6	58	45	36	40	33	27	37	31	26
7	54	41	32	36	29	24	34	27	23
8	50	37	28	33	26	21	31	25	20
9	47	34	26	30	24	19	28	22	18
10	44	31	23	28	21	17	26	20	16

Zonal Lumen Summary

Zone	Lumens	% Lamp	% Fixture
0° - 30°	455	14.9	16.0
0° - 40°	770	25.3	27.1
0° - 60°	1490	48.8	52.4
0° - 90°	2393	78.5	84.1
90° - 180°	452	14.8	15.9
0° - 180°	2846	93.3	100.0



UNS

Sealatron IP Low Profile

Enclosed Industrial Wet Location Luminaire, T5/T8

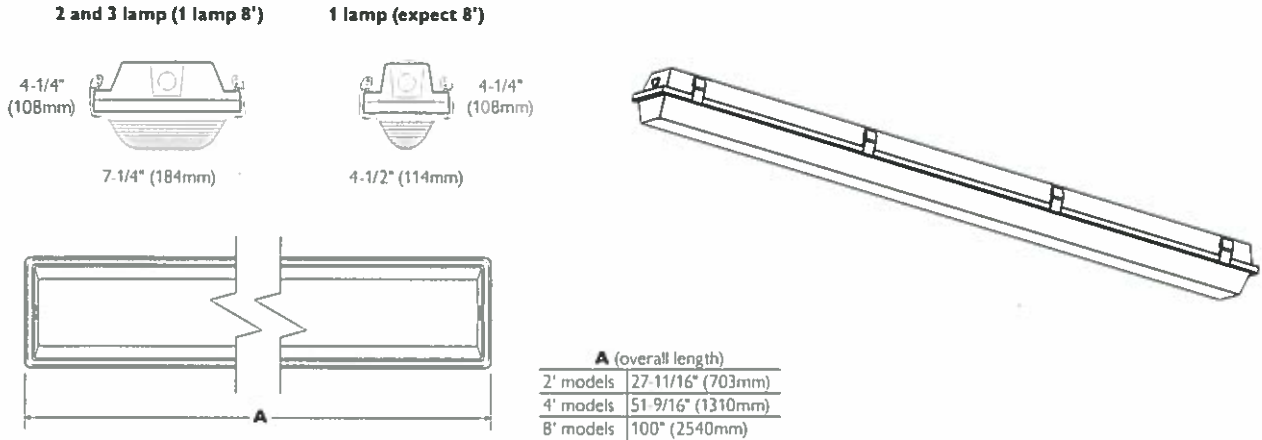

Ordering Information

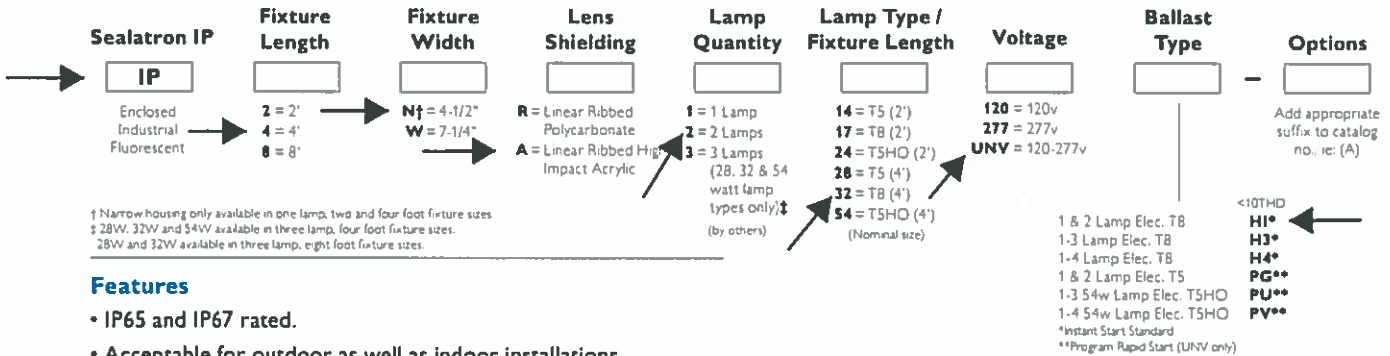

Features

- IP65 and IP67 rated.
- Acceptable for outdoor as well as indoor installations.
- Wet Location-Areas of high humidity, water vapor, rain, incidental water spray, or other non-corrosive or nonflammable liquid.
- Also suitable for damp locations.
- Non-conductive, non-corrosive housing.
- Smooth exterior surface for easy cleaning.
- Molded fiberglass 5V-A housing.
- Ribbed prismatic diffuser.
- Continuous poured gasket.
- Polycarbonate cam action latches are standard.
- Ballast is retained by a snap-on gear tray in lieu of channel, reducing weight.
- Two snap-on stainless steel mounting brackets included, can be installed anywhere along housing (except at latches)

Job Information	Type:
Job Name:	
Cat. No.:	
Notes:	

Sealatron IP Low Profile

Enclosed Industrial Wet Location Luminaire, T5/T8

Specifications

Materials: Chassis parts– Molded fiberglass 5V-A housing. Continuous poured gasket. Polycarbonate cam action latches are standard. Ballast is retained by a snap-on gear tray in lieu of channel, reducing weight.

Finish: Chassis exterior– Non-conductive, non-corrosive housing. Smooth exterior surface for easy cleaning.

Lens: IP65 and IP67 rated linear ribbed lens.

Electrical: Class P, HPF certified ballasts comply with Federal Ballast Law (Public Law 100-357, 1988). Self-contained fluorescent emergency ballasts available: Wet location only, use BDL600 or BDL500 for T8 applications. Consult factory for T5 applications.

Labels: UL/cUL listed. Wet Location UL 1570/cUL C22.2 No. 9.

This product may have a mercury containing lamp.
Manage in accord with Disposal. Laws. See: www.lamprecycle.org

Options & Accessories

Electrical Wiring Options: Consult factory.

Emergency Pack Options: Consult factory.

Fusing: Internal fast blow fusing: Suffix: **A**.
Internal slow blow fusing: Suffix: **C**.

Stainless steel latches available (consult factory).

Mounting Options

Surface mounted only. Mounting bracket included.

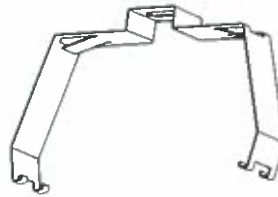

Additional ordering information:

Size	Family	Lamps X section	Lamp fixture	Available lenses	Lamp type	Length in. (mm)	Width in. (mm)	Height in. (mm)
2'	IP	1	1	R	14, 17, 24HO	27 11/16" (703)	4 1/2" (114)	4 1/4" (108)
		2	2	R	14, 17, 24HO	27 11/16" (703)	7 1/2" (184)	4 1/4" (108)
4'	IP	1	1	R	28, 32, 54HO	51 9/16" (1310)	4 1/2" (114)	4 1/4" (108)
		2	2	A, R	28, 32, 54HO	51 9/16" (1310)	7 1/2" (184)	4 1/4" (108)
		3	3	A, R	28, 32, 54HO	51 9/16" (1310)	7 1/2" (184)	4 1/4" (108)
8'	IP	1	2	A	28, 32, 54HO	100" (2540)	7 1/2" (184)	4 1/4" (108)
		2	4	A	28, 32, 54HO	100" (2540)	7 1/2" (184)	4 1/4" (108)
		3	6	A	28, 32	100" (2540)	7 1/2" (184)	4 1/4" (108)

Lens information

R	= Linear Ribbed Polycarbonate
A	= Linear Ribbed High Impact Acrylic

Job Information Type:

PHILIPS
LIGHTOLIER

Sealatron IP Low Profile

Enclosed Industrial Wet Location Luminaire, T5/T8

Photometry

Model No. IP4WA232UNVHI

LER = 66 IW = 55 BF = 0.88
Comparative yearly lighting energy cost per
1000 lumens = \$3.64

Report Number: 23312

Catalog Number: IP4WA232UNVHI

Lamps: (2) F32T8

Luminaire: Sealatron, enclosed
industrial with 25% high
impact DR acrylic lens
for wet/damp locations.

Ballast: Electronic

Report is based on 2850 lumens per lamp.

Efficiency: 66.9%

CIE Type: Direct - Indirect

Plane: 0-Deg. 90-Deg.

Spacing Criteria: 1.3 1.5

Candela Distribution

Vertical Angle	Horizontal Angle			Zonal Lumens
	0	45	90	
0	1065	1065	1065	
5	1058	1061	1061	84
15	1007	983	941	247
25	914	884	960	364
35	752	851	919	424
45	513	812	903	418
55	332	775	811	359
65	207	615	713	280
75	92	467	593	280
85	26	282	327	280
95	11	153	170	280
105	12	79	103	280
115	8	48	83	280
125	3	29	55	280
135	3	11	34	280
145	3	3	12	280
155	4	4	4	280
165	5	4	5	188
175	5	5	5	38
185	0	0	0	

Coefficients of Utilization

Ceiling Wall	80%			50%			30%			
	70	50	30	50	30	10	50	30	10	
RC	Zonal Cavity Method									
RW	Effective Floor Reflectance = 20%									
Room Cavity Ratio	1	75	70	67	72	68	65	65	61	77
	2	68	60	55	65	58	53	55	51	64
	3	60	52	46	58	51	45	47	42	54
	4	56	46	39	53	45	38	41	35	47
	5	51	40	34	48	40	33	36	32	41
	6	46	35	29	45	34	28	34	28	36
	7	42	33	26	41	32	26	29	25	32
	8	40	29	23	39	28	23	28	22	28
	9	38	27	20	35	27	20	25	20	26
	10	34	25	19	34	25	19	23	17	23

Average Luminance data in candela / sq. meter

Angle	0°	45°	90°
45	3779	4883	5134
55	2966	5260	5119
65	2443	4964	5236
75	1675	4830	5402
85	1108	4239	4086

Zonal Lumen Summary

Zone	Lumens	% Lamp	% Fixt.
0-30	802	14.1	19.5
0-40	1330	23.3	32.2
0-60	2542	44.6	61.6
0-90	3812	66.9	92.4
90-180	312	5.5	7.6
0-180	4124	72.3	100.0



Philips Lightolier
e: lol.webmaster@philips.com
c: (508) 679-8131, Technical info. (978) 657-7600
w: www.lightolier.com

Sealatron IP May 11, 2012

Specifications are subject to change without notice.
© Koninklijke Philips Electronics N.V. 2012. All rights reserved.

Job Information Type:



Project 15-20238-4
MIAMI UNIVERSITY HAHNE HALL

Submitted By
KING LIGHTING INC

Catalog Number
ZL2N L48 3000LM MDD MVOLT 40K 80CRI WH / HC36

Notes

Type

C3



FEATURES & SPECIFICATIONS

INTENDED USE — Sharing many popular Z Series elements, this solid-state strip offers long maintenance-free life, several color temperatures, lumen outputs and lengths. Ideal for new construction and retrofit applications in T5 and T8 lengths. Ideal for uplight and downlight in commercial, retail, manufacturing, warehouse, cove and display applications.

CONSTRUCTION — Compact-design channel and cover are formed from code-gauge, cold-rolled steel. Improved easy "snap 'n' lock" end plates allow for quick attachment.

Finish: Paint options include high-gloss, baked white enamel (WH), galvanized (GALV), matte black (MB) and smoke gray (SKGY). Five-stage iron phosphate pre-treatment ensures superior paint adhesion and rust resistance.

OPTICS — Replaceable medium diffuse lens (up to 10%) offer ingress protection from debris.

ELECTRICAL — Utilizes high-output LEDs integrated on a two-layer circuit board, ensuring cool-running operation. Internal pluggable wiring harness prevents wiring errors. Electronic LED driver is rated for 75 input watts maximum (see Operational Data on page two for actual wattage consumption), multi-volt input and 0-10V dimming standard. This fixture is designed to withstand a maximum line surge of 1.5kV at 0.75kA combination wave for indoor locations, for applications requiring higher level of protection additional surge protection must be provided.

LEDs provide 83 CRI at 3000 K, 3500 K, 4000 K or 5000 K.

Lumen output ranges from 2100 to 6000 lumens. Beam angle is 110 FWHM (full width at half maximum). Lumen output up to 1,300 lumens per foot. In 86°F (30°C) ambient environments, L70 is predicted to be 100,000+ hours, L85 at 44,000 hours. Luminaire should be installed in applications where ambient temperatures do not exceed 86°F (30°C). Ambient temperatures that exceed 86°F (30°C) will result in reduced life and will void warranty.

INSTALLATION — Tool-less channel cover for easy installation.

Fixture may be surface, pendant or stem mounted. Three-point aligner locks in place for easy continuous row mounting.

LISTINGS — UL Listed, CSA certified to US and Canadian safety standards. For use in damp locations between -4°F (-20°C) and 86°F (30°C).

WARRANTY — 5-year limited warranty. Complete warranty terms located at www.aqualitybrands.com/CustomerResources/terms_and_conditions.aspx

Note: Actual performance may differ as a result of end-user environment and application.

All values are design or typical values, measured under laboratory conditions at 25 °C.

Specifications subject to change without notice.



Lensed LED Striplight

ZL2N

24" and 48" Lengths



ORDERING INFORMATION

Lead times will vary depending on options selected. Consult with your sales representative.

Example: ZL2N L48 3000LM MDD MVOLT 40K 80CRI WH

ZL2N	L48	3000LM	MDD	MVOLT	40K	80CRI	WH		
Series	Length	Nominal lumens ¹	Diffuser	Voltage	Color temperature	Color rendering index	Options		Paint finish
ZL2N Lensed LED striplight	L24 24"	2000LM 2,000 lumens	MDD Medium diffuse	MVOLT 120-277V	40K 4000 K	80CRI 80 CRI	PLR Plug-in wiring ³	WH White	
	L46 46"	2000LM 2,000 lumens	ZSD Zebra striped lens	HVOLT 347-480V ⁴	30K 3000 K	90CRI 90 CRI	PLR1LVG Plug-in wiring low voltage ⁴	GALV Galvanized	
	L48 48"	3000LM 3,000 lumens			35K 3500 K	BSL722 Emergency battery pack ^{5,6}	MB Matte black		
		5000LM 5,000 lumens		50K 5000 K			SKGY Smoke gray		

HC36

Accessories: Order as separate catalog number.

ZACVH	Aircraft cable with hook
HC36	Hanger chain, 36"
ZSPRG	For 15/16" T-grid only
LSXR	Sensor Switch* LSXR occupancy sensor ⁷

Replacement Lens

L2L2 XX MDIF Medium-diffuse lens. Specify length 24 or 48 (example: L2L2 24 MDIF)⁷

Notes

- See Operational Data on page 2 for actual lumens
- Not available with L24, 24" fixture.
- See ordering information on page 3.
- Use ZSPRG for surface mounting when order this option.
- Specify voltage, 120 or 277.
- Output is 1400 lumens.
- XX denotes length.



Project 15-20238-4
 MIAMI UNIVERSITY HAHNE HALL
 Submitted By
 KING LIGHTING INC

Catalog Number
 ZL2N L48 3000LM MDD MVOLT 40K 80CRI WH / HC36

Type

C3

ZL2N LED Striplight

OPERATIONAL DATA							
Nominal lumen package	Length (Inches)	Delivered lumens 3000 K CCT @ 77°F (25°C) ambient temperature	Delivered lumens 3500 K CCT @ 77°F (25°C) ambient temperature	Delivered lumens 4000 K CCT @ 77°F (25°C) ambient temperature	Delivered lumens 5000 K CCT @ 77°F (25°C) ambient temperature	Wattage @ 120V/277V	Comparable light source
2,000LM	24	2,009	2,092	2,249	2,457	34W/32W	1-lamp 32W T8, 1-lamp 54W T5HO, 50W HID
2,000LM	46 or 48	1,830	1,905	2,048	2,237	32W/31W	1-lamp 32W T8, 1-lamp 54W T5HO, 50W HID
3,000LM	46 or 48	2,835	2,952	3,173	3,467	42W/41W	2-lamp 32W T8, 1-lamp 54W T5HO, 70W HID
5,000LM	46 or 48	4,274	4,450	4,784	5,226	72W/70W	2-lamp 32W T8, 1-lamp 54W T5HO, 70W HID

PROJECTED LUMEN MAINTENANCE								
Operating hours	0	10,000	20,000	30,000	40,000	50,000	60,000	100,000
Lumen maintenance factor	1	0.9466	0.9173	0.8888	0.8613	0.8346	0.8088	0.7131
Based on incomplete LM-80 data. Update expected Q1 2014.								

DIMENSIONS

All dimensions are shown in inches (centimeters) unless otherwise noted.
 Specifications subject to change without notice.

PALLET DIMENSIONS			
Length	Approximate weight	Fixtures per pallet	Approximate pallet dimensions (L x W x H)
L24	6 lbs	408	46" x 46" x 32-11/16"
L46	8 lbs	178	46" x 46" x 31-1/3"
L48	8 lbs	178	46" x 46" x 31-1/3"
L92	16 lbs	176	98-1/2" x 46" x 31-1/16"
L96	16 lbs	176	98-1/2" x 46" x 31-1/16"

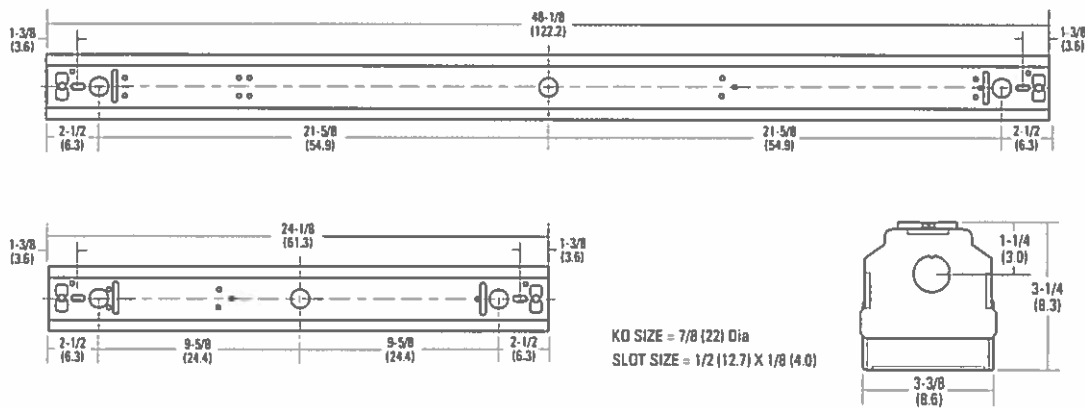

PHOTOMETRICS

Please see www.lithonia.com.



Project 15-20238-4
 MIAMI UNIVERSITY HAHNE HALL
 Submitted By
 KING LIGHTING INC

Catalog Number
 ZL2N L48 3000LM MDD MVOLT 40K 80CRI WH / HC36

Type

C3

ZL2N LED Striplight

PRODUCT INFORMATION

Advanced plug-in system with three-circuit capability. Available on Industrial and strip products and a variety of architectural products mounted in continuous rows. 1, 2, 3 and 4-lamp fixtures. PLR22 (2-circuit) and PLR33 (3-circuit) crossover harness switches hot circuit serving next fixture in row. Reduces fixture types on job for alternating circuit applications (see example below.)

Easy one-step installation, saves up to 35% on labor costs. Expanded switching flexibility helps save energy. Rows can be 50% longer with two-circuit systems. Polarized, lock together nylon connectors prevent miswiring in the field. #12 THHN conductor, rated 600V, 90°C. White neutral wire included. Grounding accomplished by fixture in-row connectors.

CSA certified systems available with up to 2 circuits. G ground required.

Note: Specifications subject to change without notice.

Wiring

PLR

Advanced 3-Circuit Plug-in



ORDERING INFORMATION Lead times will vary depending on options selected. Consult with your sales representative.

Series	Number of hot wires	Branch circuits	Dimming	Ground
PLR	(blank) Not required for 22 or 33	Circuits to which ballasts connected B Red wire	LV Low-voltage dimming	(blank) No ground in PLR
PLR22	1 Black	(blank) Not required for 22 or 33 C Blue wire		G Ground. Maximum 2 circuits
PLR33	2 Black and red	A Black wire		
	3 Black, red and blue			

Typical Applications

- Multiple-circuit and single-circuit for longer continuous rows
- Multiple-circuit with alternating fixtures on separate circuits, 2-circuit (PLR 22) and 3-circuit (PLR 33)
- Multiple circuit with night lights located along row as desired

TYPICAL APPLICATIONS										
PLR 3 C	PLR 3 C	PLR 3 C	PLR 3 C	PLR 2 B	PLR 2 B	PLR 2 B	PLR 2 B	PLR 1	PLR 1	PLR 1
(All PLR22)										
Circuit A	Circuit B	Circuit A	Circuit B	Circuit A	Circuit B	Circuit A	Circuit B	Circuit A	Circuit B	Circuit A
(All PLR33)										
Circuit A	Circuit B	Circuit C	Circuit A	Circuit B	Circuit C	Circuit A	Circuit B	Circuit C	Circuit A	Circuit B
PLR 3 A	PLR 3 A	PLR 3 A	PLR 3 C	PLR 3 B	PLR 3 B	PLR 3 B	PLR 3 C	PLR 3 A	PLR 3 A	PLR 3 A

PRODUCT INFORMATION

A standard occupancy time delay is also present to ensure lights turn off (once minimum on timer has also elapsed) if no occupancy is detected.

This timer is factory set at 10 minutes to promote energy savings, but is adjustable between 30 seconds and 30 minutes. These adjustments may be done through the unit's push-button.

FEATURES

- Four interchangeable lenses - high mount 360°, low mount 360°, high mount aisleway, and small motion 360°.
- Integrated mounting bracket drops lens down 3" from chase nipple - no bracket accessory required.
- 100% digital PIR detection - provides excellent RF immunity

Note: Specifications subject to change without notice.

Passive Infrared Indoor Occupancy Sensor

LSXR

Single Relay



ORDERING INFORMATION Lead times will vary depending on options selected. Consult with your sales representative.

Example: LSXR 10 ADC HVOLT 30M

LSXR		Lens option				Dimming/photocell	
Series	Passive Infrared Indoor Occupancy Sensor	(blank)	No lens	610	High and low mount 360°	(blank)	None
		6	High mount, 360°	650	High mount 360° and aisleway	HL	High/low occupancy operation
		10	Low mount, 360°	3PK	High and low mount 360° and aisleway	P	Switching photocell (on/off)
		50	High mount aisleway	4PK	All lenses	ADC	Dimming and switching photocell
		9	Small motion, 360°			ANL	Dimming and switching photocell with high/low occupancy operation

MVOLT	Temp humidity	Default time delay																																											
<table border="1"> <thead> <tr> <th>Voltage</th> <th>Max dim level</th> <th>Min dim level</th> <th>Lead length</th> </tr> </thead> <tbody> <tr> <td>(blank) 120-277 VAC (MVOLT)</td> <td>(blank) 10 VDC</td> <td>(blank) Minimum dimming level of ballast</td> <td>(blank) 14"</td> </tr> <tr> <td>HVOLT 347-480 VAC</td> <td>9H 9 VDC</td> <td>1V 1 VDC</td> <td>42L 42"</td> </tr> <tr> <td></td> <td>8H 8 VDC</td> <td>2V 2 VDC</td> <td></td> </tr> <tr> <td></td> <td>7H 7 VDC</td> <td>3V 3 VDC</td> <td></td> </tr> <tr> <td></td> <td></td> <td>4V 4 VDC</td> <td></td> </tr> <tr> <td></td> <td></td> <td>5V 5 VDC</td> <td></td> </tr> <tr> <td></td> <td></td> <td>6V 6 VDC</td> <td></td> </tr> </tbody> </table>	Voltage	Max dim level	Min dim level	Lead length	(blank) 120-277 VAC (MVOLT)	(blank) 10 VDC	(blank) Minimum dimming level of ballast	(blank) 14"	HVOLT 347-480 VAC	9H 9 VDC	1V 1 VDC	42L 42"		8H 8 VDC	2V 2 VDC			7H 7 VDC	3V 3 VDC				4V 4 VDC				5V 5 VDC				6V 6 VDC		<table border="1"> <thead> <tr> <th>Temp humidity</th> <th>Default time delay</th> </tr> </thead> <tbody> <tr> <td>(blank) None</td> <td>(blank) 10 minutes (with minimum 15 minutes on time)</td> </tr> <tr> <td>LT Low temperature</td> <td>5M 5 minutes (LED only)</td> </tr> <tr> <td></td> <td>15M 15 minutes</td> </tr> <tr> <td></td> <td>20M 20 minutes</td> </tr> <tr> <td></td> <td>30M 30 minutes</td> </tr> </tbody> </table>	Temp humidity	Default time delay	(blank) None	(blank) 10 minutes (with minimum 15 minutes on time)	LT Low temperature	5M 5 minutes (LED only)		15M 15 minutes		20M 20 minutes		30M 30 minutes
Voltage	Max dim level	Min dim level	Lead length																																										
(blank) 120-277 VAC (MVOLT)	(blank) 10 VDC	(blank) Minimum dimming level of ballast	(blank) 14"																																										
HVOLT 347-480 VAC	9H 9 VDC	1V 1 VDC	42L 42"																																										
	8H 8 VDC	2V 2 VDC																																											
	7H 7 VDC	3V 3 VDC																																											
		4V 4 VDC																																											
		5V 5 VDC																																											
		6V 6 VDC																																											
Temp humidity	Default time delay																																												
(blank) None	(blank) 10 minutes (with minimum 15 minutes on time)																																												
LT Low temperature	5M 5 minutes (LED only)																																												
	15M 15 minutes																																												
	20M 20 minutes																																												
	30M 30 minutes																																												

For additional information see www.lithonia.com



Project 15-20238-4
MIAMI UNIVERSITY HAHNE HALL

Submitted By
KING LIGHTING INC

Catalog Number
ZL2N L48 3000LM MDD MVOLT 40K 80CRI WH / HC36

Notes

Type

C3

ZL2N LED Striplight

OPTIONS AND ACCESSORIES

The Z Series fixture offers numerous options for almost every electrical and optical component, including a long list of field-installable accessories.

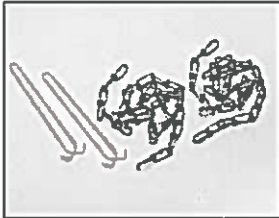

HANGER CHAIN
36" chain with Y hanger.

Order as:
HC36

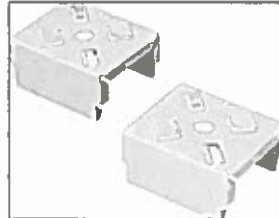

Z SPRING HANGER
Snap'n'lock design requires no fasteners and can be used on T-grid ceiling or universal mounting systems.

Order as:
ZSPRG



ZACVH HANGER
10' Aircraft cable with Y hanger.

Order as:
ZACVH



Catalog Number
Notes
Type

FEATURES & SPECIFICATIONS

INTENDED USE — For applications that require the clean appearance of a flat-bottom diffuser. Provides high light levels for storage rooms, offices or retail applications. **Certain airborne contaminants can diminish integrity of acrylic. Click here for Acrylic Environmental Compatibility table for suitable uses.**

CONSTRUCTION — Linear side prisms control brightness, pyramidal bottom prisms minimize lamp image. Continuous side flanges on fixture body provide light trap and continuous diffuser support to prevent accidental opening and simplify maintenance. Full depth, white enamel end plates.

Die-formed from code gauge cold-rolled steel. Channel cover snaps into place without the use of tools. Full end cap factory installed to reduce job site labor. Diffuser is extruded clear acrylic.

Finish: Five-stage iron-phosphate pretreatment ensures superior paint adhesion and rust resistance. Finished with high-gloss, baked white enamel.

ELECTRICAL — Thermally protected, resetting, Class P, HPF, UL listed, CSA Certified ballast is standard. Energy saving and electronic ballasts are sound rated A.

Luminaire is suitable for damp locations. AWM, TFN or THHN wire used throughout, rated for required temperatures.

INSTALLATION — For surface or stem mounting, individual or row installation.

LISTINGS — UL listed to U.S. and Canadian Safety Standards. Optional: Canada CSA or Mexico NOM

WARRANTY — 1-year limited warranty. Complete warranty terms located at

www.acuitybrands.com/CustomerResources/Terms_and_conditions.aspx

Note: Specifications subject to change without notice.

Square-Basket Wraparound

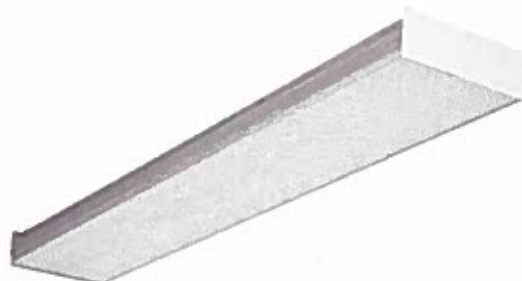

SB

T8/T5
NARROW BODY
2', 4' or 8' lengths
2 lamps



Specifications

T8 Length:	24 (61.0)
	48 (122.0)
	96 (243.9)
T5 Length:	22-1/2 (57.2)
	46-1/2 (118.1)
	92-1/2 (235.0)
Width:	8-3/8 (21.2)
Depth:	2-5/8 (6.7)

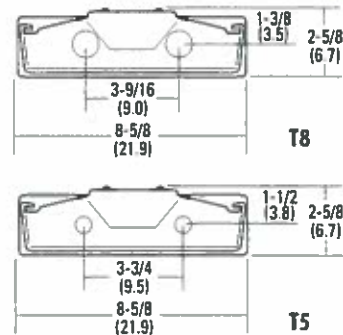

All dimensions are inches (centimeters) unless specified otherwise.

ORDERING INFORMATION

For shortest lead times, configure products using standard options (shown in bold.)

Example: SB 2 32 MVOLT GEB10IS

Series	Lamp type	Voltage	Options
SB 2	2 lamps, 8-3/8" wide		
	17 17W T8 (24")	120	Shipped installed in fixture
	32 32W T8 (48")	277	GEB10IS Electronic ballast, ≤10% THD, instant start
	14T5 14W T5 (22-1/2")	347	GEB10PS Electronic ballast, ≤10% THD, program start
	28T5 28W T5 (46-1/2")	MVOLT¹	GEB95 .95 ballast factor T5 ²
	54T5HO 54W T5 HO (46-1/2")		GEB95S .95 ballast factor T5 step dimming ²
			EL Emergency battery pack (nominal 300 lumens, see Life Safety Section) ³
			EL14 Emergency battery pack (nominal 1400 lumens, see Life Safety Section) ³
			GLR Internal fast-blow fuse ⁴
			GMF Internal slow-blow fuse ⁴
			RE 120V residential electronic ballast ⁵
			CSA Listed and labeled to comply with Canadian Standards
			NOM NDM certified
			SSR Specular silver interior finish (95% reflective)

Accessories: Order as separate catalog number.

- SQ Swivel-stem hanger (specify length in 2" increments)
- 1B Ceiling spacer (1-1/2" to 2-1/2" from ceiling)

Notes

1. Electronic ballast 120 through 277V only.
2. Only available with 14T5 or 28T5.
3. Not available with T5 2' configuration.
4. Must specify voltage.
5. Must specify voltage, 120V. Energy Star[®] qualified.

SB Square Basket Wraparound, Narrow Body

MOUNTING DATA

For unit or row installation. Surface or stem mounting. Stem mounting is not available with TSB.

UNIT INSTALLATION — Minimum of two hangers required.

ROW INSTALLATION — One hanger per fixture plus one per row required.

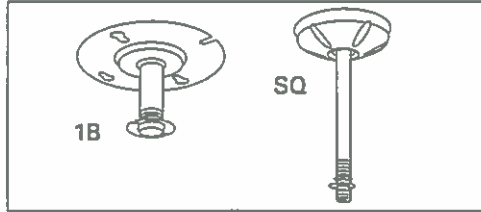

DIMENSIONS

All dimensions are inches (centimeters). Specifications subject to change without notice.

A = 1/4 x 1/2 (64 x 13) Oval Hole

B = 11/16 (17) Dia. K.O.

C = 7/8 (22) Dia. K.O.

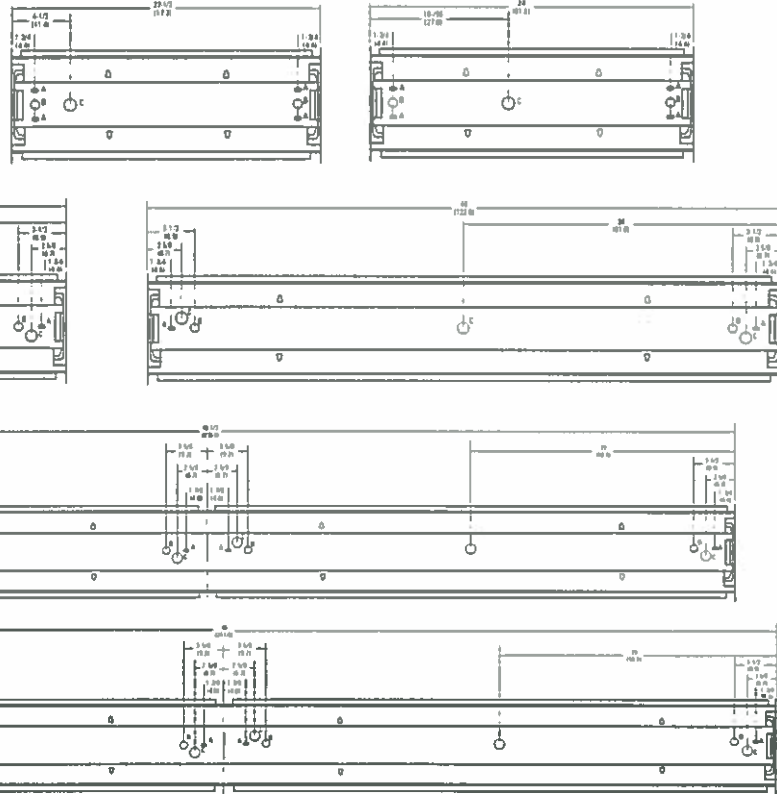

PHOTOMETRICS

Calculated using the zonal cavity method in accordance with IESNA LM41 procedure. Floor reflectances are 20%. Lamp configurations shown are typical. All data based on 25°C. Full photometric data on these and other configurations available upon request.

Test # BAL16519 - SB 2 32 MVOLT GEB1015

pc	Coefficients of Utilization												
	20%												
	80%			50%			30%			10%			0%
10%	50%	30%	10%	50%	30%	10%	50%	30%	10%	50%	30%	10%	0%
0	107	107	107	97	97	97	90	90	90	84	84	84	82
1	93	90	86	85	82	79	79	77	75	74	73	71	68
2	82	76	71	75	70	66	70	66	63	66	63	60	58
3	73	65	60	66	61	56	62	58	54	59	55	52	49
4	65	57	51	59	53	48	56	51	47	53	48	45	43
5	58	50	44	53	47	42	50	45	41	48	43	39	37
6	52	44	39	48	42	37	46	40	36	43	39	35	33
7	47	40	34	44	38	33	42	36	32	40	35	31	29
8	43	36	31	40	34	29	38	33	29	37	32	28	26
9	40	32	28	37	31	27	35	30	26	34	29	25	24
10	37	30	25	34	28	24	33	27	24	31	26	23	21

Zone	lumens	% lamp	% fixture
0-30	1,444.3	24.5	26.6
0-40	2,374.5	40.2	43.7
0-60	3,953.3	67.0	72.8
0-90	4,821.6	81.7	88.8
90-180	1,806.1	31.3	11.2
0-180	5,431.9	92.1	100.0

Test # LTL 19931 - SB 2 28 T5 GEB95

Coefficient of Utilization - Zonal Cavity Method

RCC%	Effective Floor Cavity Reflectance: 20%																	
	20%																	
	80%			70%			50%			30%			0%					
RW%	70	50	30	0	70	50	30	0	50	30	20	50	30	20	50	30	20	0
0	1.03	1.03	1.03	1.03	1.00	1.00	1.00	.79	.93	.93	.93	.87	.87	.87	.82	.82	.82	.79
1	.94	.90	.86	.83	.91	.87	.84	.67	.82	.79	.77	.77	.75	.73	.72	.71	.69	.67
2	.86	.79	.74	.69	.83	.77	.72	.57	.72	.68	.64	.68	.65	.61	.64	.61	.59	.56
3	.79	.70	.63	.58	.76	.68	.62	.50	.64	.59	.55	.61	.56	.53	.57	.54	.51	.48
4	.73	.63	.55	.50	.70	.61	.54	.43	.58	.52	.47	.54	.50	.46	.52	.47	.44	.42
5	.67	.56	.49	.43	.65	.55	.48	.38	.52	.46	.41	.49	.44	.40	.47	.42	.39	.37
6	.62	.51	.43	.38	.60	.50	.42	.34	.47	.41	.36	.45	.39	.35	.48	.38	.34	.32
7	.58	.46	.39	.34	.56	.45	.38	.30	.43	.37	.32	.41	.36	.31	.39	.34	.31	.29
8	.54	.42	.35	.30	.52	.41	.34	.27	.39	.33	.29	.38	.32	.28	.36	.31	.28	.26
9	.50	.39	.32	.27	.49	.38	.31	.25	.36	.30	.26	.35	.29	.26	.33	.28	.25	.23
10	.47	.36	.29	.25	.46	.35	.29	.23	.34	.28	.24	.32	.27	.23	.31	.26	.23	.21

Zonal Lumens Summary

Zone	lumens	% lamp	% fixture
0-30	1,274.4	24.5	27.7
0-40	2,085.0	40.1	45.3
0-60	3,401.4	65.4	73.9
60-90	726.3	14.0	15.3
70-100	483.1	9.3	10.5
90-120	350.6	6.7	7.6
0-90	4,127.8	79.4	89.6
90-180	476.6	9.2	10.4
0-180	5,604.4	88.5	100



SBN

SAT-SM-DIM-UL-(CHERRY OR BEECH)-120V-ADVISE FINISH



TYPE C6
SUSPENSION

MEDIUM SUSPENSION / **Saturnia**
by Oskar Cerezo

Wood shade colors	Info	References
-------------------	------	------------

- 20 Ivory White
- 21 Natural Cherry
- 22 Natural Beech
- 24 Yellow
- 25 Orange
- 26 Red
- 28 Blue
- 30 Turquoise
- 31 Chocolate

ADVISE FINISH



Light Emission
Direct / Diffused

Certificates



Class I

120V - 277V

SAT SM MULTIVUL
SAT SM DIM UL
Dimmable



Packaging	Components
-----------	------------



Box size
43 x 43 x 13"



Weight
Gross - 31,9 Lb
Net - 15,2 Lb



Metal canopy
Brushed nickel
ø 4,8"

Electrical cable
Transparent
8 ft drop



Steel cable
3 x 8 ft drop



Top diffuser
Black or White



It's important to select top diffuser colour

Bottom diffuser
Matt satin acrylic

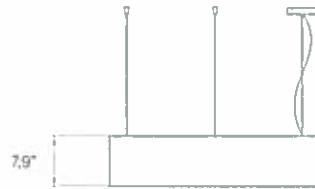

Recommended tube (Not Included)



Linear fluorescent
3 x 24 w



Standard fit: Lutron
For other options, please specify dimming needs

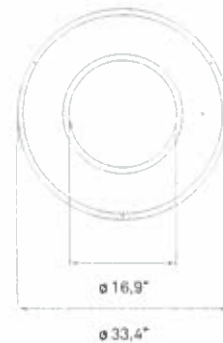

Unique Handmade Wood Lighting since 1994

MEDIUM SUSPENSION / **Saturnia**
by Oskar Cerezo

Reference	Units	Ballast Reference	Family	Brand
SAT SM MULTIV UL	2	RHA-UNV-239-LT5	RACEHORSE	FULHAM www.fulham.com
SAT SM DIM UL Dimmable	1 + 1	EC5 T524 J UNV 1 + EC5 T524 J UNV 2	ECOSYSTEM + ECOSYSTEM	LUTRON www.lutron.com LUTRON www.lutron.com
SAT SM DIM UL (0-10) Dimmable 0-10V	1 + 1	HSM-UNV-139-LT5 + HSM-UNV-239-LT5	LIGHTING CONTROLS + LIGHTING CONTROLS	FULHAM www.fulham.com FULHAM www.fulham.com



SAT SM DIM UL (0-10)
Dimmable 0-10V



PROVIDE 0-10V DIMMING

NOTE

These are our standard options, for other options, please specify dimming needs.





Project 15-20238-4
 MIAMI UNIVERSITY HAHNE HALL
 Submitted By
 KING LIGHTING INC

Catalog Number
 SG5V126EX/AR5315SG/FGCY5

Notes

Type

D1

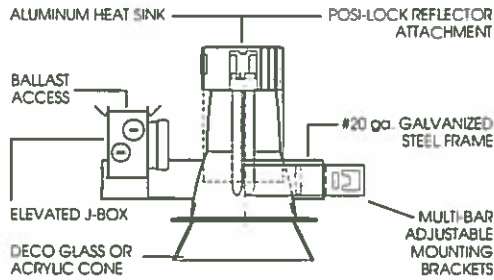

5" VERTICAL FLUORESCENT FLARED DECO COLLAR

1 x 42 WATT MAX COMPACT FLUORESCENT



SG5V

APPLICATION

Flared acrylic or glass deco collar.
 Open reflector allows full fixture performance.

FEATURES

Efficient reflector design optimized for CFL lamps.
 Posi-lock reflector attachment.
 Integral 5/8" (0.625) plaster ring.
 Tool-less ballast access.
 Multi-bar adjustable mounting brackets.

FINISH

Variety of powdercoat and anodized finishes available on reflector.
 Eco Black (EB) finish available on frame/ housing.

ELECTRONICS

Ballasts are integrally mounted, electronic sound rated "A", Class P, multi-volt 120v - 277v.

CONSTRUCTION

Frame constructed of 20 ga. galvanized steel.
 Reflectors spun from .063 high purity aluminum & finished to specification.

LABELS

Manufactured and tested to UL 1598.
 UL/ ETL Listed for Damp Locations.

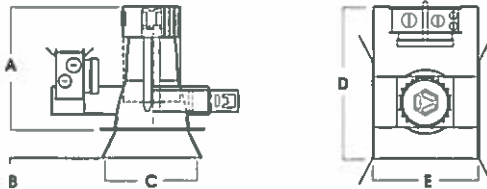
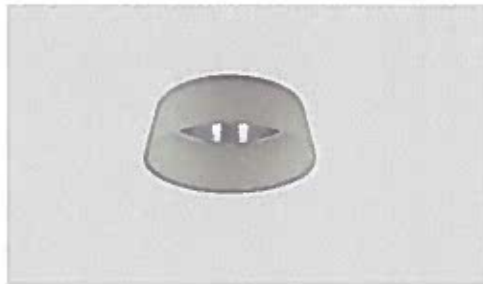

A	B	C	D	E
7.3	1.0	6.9	10.3	8.0
184.2 mm	25.4 mm	174.5 mm	260.4 mm	203.2 mm

Max Ceiling Thickness:	1.5 (38.1 mm)
Ceiling Cutout:	5.2 Ø (133.4 mm Ø)
Fixture Weight:	4.0 lbs

FIXTURE LAMPING
13 CFL - GX24Q-1
18 CFL - GX24Q-2
26/32/42 CFL - GX24Q-3/4

SERIES	WATTS	BALLAST	OPTIONS	TRIM / FINISH	TRIM OPTIONS
SG5V- Spectrum Gold 5" Vertical Flared Deco Collar	113 118 126 132 142	EX -Electronic- 120v-277v DA1 -Advance Mark 10 TM -120v ¹ DA2 -Advance Mark 10 TM -277v ¹ DM7 -Advance Mark 7 TM -120v-277v DLE -Lutron ECO System TM / HI Lume 120v-277v	BH27 -STD Bar Hangers (Supplied) CB24 -C-Channel Bars CCEA -Chicago Ceiling Plenum CR -Corrosion Resistant EM1 -EM Battery, 120V EM2 -EM Battery, 277V FS -Fuse Holder and Fuse IC -Insulation Contact (See IC Options Pages for Dimensions) PR -Plaster Ring (Special Depth) TBC -T-bar Clips (Fit BH27) TST -Twist-Lok Socket EB -Eco Black Housing Finish SCA -Slope Ceiling Adaptor	AR5315-SG -Semi-Diffuse Low Iridescant (Standard) CL -Clear Bright Alzak GO -Gold Alzak HZ -Matte Low Iridescant PW -Pewter Alzak UM -Umber Alzak WE -Wheat Alzak BL -Black Finish WH -White Finish PF -Polished Flange	GS -Gasket GR5 -5" Goff Ring FGPY -Frosted Glass Flared Cone Trim FAPY -Frosted Acrylic Flared Cone Trim OGPY -Opal Glass Flared Cone Trim OAPY -Opal Acrylic Flared Cone Trim FGCY5 See Next Page
		¹ Not Available for 13w Quad or TRT Lamp	Refer to Architectural Downlight Options Pages	Note: White Range is Standard.	*For Available Decorative Architectural Trims See Deco Trim Options or Consult Factory.

EXAMPLE: SG5V 132 EX/ AR5315 SG FAPY

Dimensions shown are nominal. Spectrum Lighting is continually improving products and reserves the right to make changes that will not alter performance or appearance with or without written notice.



WWW.SPECLIGHT.COM • 994 JEFFERSON STREET, FALL RIVER, MA 02721 • 508.678.2303 FAX 508.678.2260





SPECTRUM
DECORATIVE TRIM
FROSTED
ACRYLIC CYLINDER

FACY
SERIES

FEATURES:

- FACY option frosted acrylic cylinder is installed directly to the reflector can be ordered in 5" and 3" lengths.
- Spectrum FACY series features a machined cast acrylic cylinder.
- This acrylic cylinder is rolled into the reflector using a proprietary system so there are no fasteners or visible hardware.
- Acrylic cast, UV stabilized, machined and frosted for a uniform finish.
- Suitable for compact fluorescent, metal halide and incandescent lamps.

DECO-TRIM MODEL #	FINISHES
FACY3- 3" Deep Frosted Acrylic	Sandblasted Acrylic Tube
FACY5- 5" Deep Frosted Acrylic	

TRIM DIMENSIONS

APERTURE		4"	5"	6"	7"
3" DEEP FROSTED CYLINDER	A: Diameter	4.0	5.0	6.0	6.5
	B: Height	3.0	3.0	3.0	3.0
5" DEEP FROSTED CYLINDER	A: Diameter	4.0	5.0	6.0	6.5
	B: Height	5.0	5.0	5.0	5.0

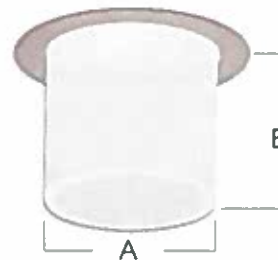

SPECIFICATIONS:

<p>1</p>	<p>2</p>	<p>3</p>	<p>4</p>	<p>5</p>
<p>Choose FIXTURE from SG SERIES (Aperture and Housing)</p> <p>SG5V</p>	<p>Specify LAMP (Watts, Ballast, and Voltage)</p> <p>126 EX</p>	<p>Choose REFLECTOR (Trim, Options, Color and Finish)</p> <p>AR5315</p>	<p>Choose DECO-TRIM (Trim Model Number)</p> <p>FACY5</p>	<p>FINISH SPECIFICATION</p> <p>SG5V 126 EX AR5315 FACY5</p>

Dimensions shown are nominal. Spectrum Lighting is continually improving products and reserves the right to make changes that will not alter performance or appearance with or without written notice.

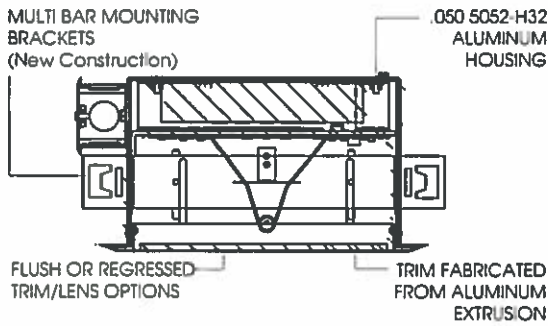

12" SQUARE LENSED
OA SERIES / 47 WATT MAX LED



SR12SQLEDOA

APPLICATION

INFINIUM™ 12" Square LED soffit/area light.

FEATURES

Efficient, powerful LED light source, designed to exceed 50,000 hours of life. (L70) Multi-Bar mounting brackets. Tamper-resistant option (TP). All LED modules and drivers are replaceable and up-gradeable. New and Retrofit/Remodeler options. Tamper Resistant and Wet location use screws fasteners. (4)

FINISH

Variety of powdercoat finishes available on trim.

ELECTRONICS

LED module features high brightness white Nichia LEDs. 3-step MacAdam Ellipses binning and CRI 84 minimum. Variety of electronic 120v/277v and dimming drivers.

CONSTRUCTION

Housing constructed of .050 5052-H32 aluminum. Trim fabricated from aluminum extrusion and finished to specification.

CODE COMPLIANCE

Energy Star qualified. ARRA Compliant. Non-IC rated. ETL/UL/CSA listed for damp locations. LM79/LM80/TM21 data available. Optional Wet location. Manufactured and built to UL standards No. 1598/8750.

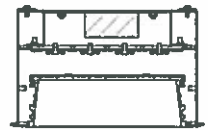
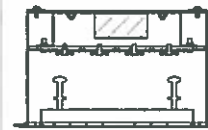
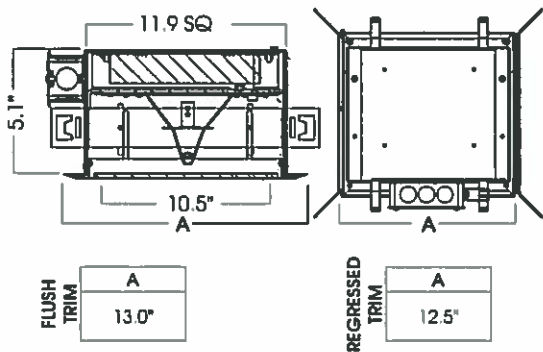

SERIES	LED	KELVIN	DRIVER	OPTIONS	TRIM / FINISH / OPTIONS												
SR12SQLEDOA	14W 26W 37W 47W	27K-2700° K 30K-3000° K 35K-3500° K 40K-4000° K 50K-5000° K	E1-Electronic, 120v E2-Electronic, 277v DS101-Spectrum 0-10v Dimming, 120v to 10% DS102-Spectrum 0-10v Dimming, 277v to 10%	BH27 27" Mounting Bars Standard BH6-6"-12" Expandable Mounting Bars BH12-12"-24" Expandable Mounting Bars CB24-C-Channel bars FS-Fuse Holder and Fuse EM1-Emergency Battery Pack, 120v EM2-Emergency Battery Pack, 277v CR-Corrosion Resistant RM-Remodeler Housing	<table border="1"> <thead> <tr> <th>FLUSH TRIM</th> <th>FINISH</th> <th>LENS</th> </tr> </thead> <tbody> <tr> <td>FT1212 Flush Extruded Aluminum Door</td> <td>MW-Matte White GW-Glass White MB-Matte Black GB-Glass Black BZ-Bronze PT-Platinum CC-Custom Color</td> <td>FO-Matte White Acrylic Lens 90% Efficient SO-Solite Lens PG-Prismatic Glass Lens WL-Wet Location Trim Secured with 4 Screws TP-Tamper Resistant</td> </tr> <tr> <th>REGRESSED TRIM</th> <td></td> <td></td> </tr> <tr> <td>RT1212 Regressed Extruded Aluminum Door</td> <td></td> <td></td> </tr> </tbody> </table>	FLUSH TRIM	FINISH	LENS	FT1212 Flush Extruded Aluminum Door	MW-Matte White GW-Glass White MB-Matte Black GB-Glass Black BZ-Bronze PT-Platinum CC-Custom Color	FO-Matte White Acrylic Lens 90% Efficient SO-Solite Lens PG-Prismatic Glass Lens WL-Wet Location Trim Secured with 4 Screws TP-Tamper Resistant	REGRESSED TRIM			RT1212 Regressed Extruded Aluminum Door		
FLUSH TRIM	FINISH	LENS															
FT1212 Flush Extruded Aluminum Door	MW-Matte White GW-Glass White MB-Matte Black GB-Glass Black BZ-Bronze PT-Platinum CC-Custom Color	FO-Matte White Acrylic Lens 90% Efficient SO-Solite Lens PG-Prismatic Glass Lens WL-Wet Location Trim Secured with 4 Screws TP-Tamper Resistant															
REGRESSED TRIM																	
RT1212 Regressed Extruded Aluminum Door																	

*Source Lumens Delivered. Lumens Available on Individual led files

Consult Factory for Additional Dimming Options

EXAMPLE: SR12SQLEDOA14W35KE1/BH27/FT1212GW/FO

Dimensions shown are nominal. Spectrum Lighting is continually improving products and reserves the right to make changes that will not affect performance or appearance with or without written notice.



PROJECT:	TYPE:
CAT. NO.:	





Project 15-20238-4
 MIAMI UNIVERSITY HAHNE HALL
 Submitted By
 KING LIGHTING INC

Catalog Number
 WL4 20L EZ1 LP840 N100 NESPDT7 DIM10
 Notes

Type
 E

LITHONIA LIGHTING

FEATURES & SPECIFICATIONS

INTENDED USE — For wall or ceiling mounting, vertical or horizontal. The WL combines digital LED lighting and controls technologies with high-performance optical design to offer the most advanced wall-mount luminaire for general ambient lighting applications. High-efficacy light engine delivers long life and excellent color, ensuring a superior quality lighting installation that is highly efficient and sustainable.

CONSTRUCTION — Housing is roll formed from code-gauge steel.

Refractor is retained in die cast ends providing secure installation and easy maintenance.

Decorative die-cast end caps provide added durability.

Finish: All metal parts are post-painted in white polyester powder coat for smooth, finished edges and uniform light distribution.

OPTICS — Impact modified linear faceted refractor. Optically engineered for superior light distribution and maximum efficacy.

Crescent-shape linear faceted refractor system obscures and integrates individual LED images and uniformly washes fixture surface with light.

ELECTRICAL — Long-life LEDs, coupled with high-efficiency drivers, provide superior quantity and quality of illumination for extended service life. 90% LED lumen maintenance at 60,000 hours (L90/60,000). The LEDs have a CRI of 82.

eldoLED driver options deliver choice of dimming range and choices for control, while assuring flicker-free, low-current inrush, 89% efficiency and low EMI.

Driver disconnect provided where required to comply with US and Canadian codes.

CONTROLS — Optional nLight™ embedded controls continuously monitor system performance and allow for constant lumen management function.

Lumen Management: Unique lumen management system (option N80) provides onboard intelligence that actively manages the LED light source so that constant lumen output is maintained over the system life, preventing energy waste created by the traditional practice of over-lighting.

Integral occupancy control: Integrated occupancy sensors allow luminaire to power off or dim to 10% or 50% output when space is unoccupied. Fixture designed to fall on.

The nES 7 is ideal for small rooms without obstructions or areas with primarily walking motion (e.g. corridors, stairwells). Additionally, the nES7ADCX includes an integrated photocell, which enables daylight harvesting. For rooms like restrooms and private offices or any space with obstructions, the nES PDT 7 dual technology sensor is recommended. The nES PDT 7 utilizes both PIR (passive Infrared) and Microphonics™ technologies to detect occupancy.

Wireless networking: XPoint™ Wireless technology creates a mesh network to ensure communication between fixtures, sensors and wall stations facility-wide. This option provides superior lighting management capabilities including granular control, configuration and custom grouping. This option enables sensors that detect motion to wirelessly communicate to neighboring fixtures — whether

W SERIES

Wall bracket & Surface Mount LED



WL4

4'
LED



eldoLED

on different floors in a stairwell, to a corridor or hallway — illuminating the desired path.
LISTINGS — CSA certified to meet U.S. and Canadian standards. Suitable for damp location. Patents pending. DesignLights Consortium® (DLC) qualified product. Not all versions of this product may be DLC qualified. Please check the DLC Qualified Products List at www.designlights.org/DPL to confirm which versions are qualified.

WARRANTY — 5-year limited warranty. Complete warranty terms located at www.acuitybrands.com/CustomerResources/terms_and_conditions.aspx

NOTE: Actual performance may differ as a result of end-user environment and application.

All values are design or typical values, measured under laboratory conditions at 25°C.

Specifications subject to change without notice.

ORDERING INFORMATION

Lead times will vary depending on options selected. Consult with your sales representative

Example: WL4 30L EZ1 LP840

WL4	20L	Voltage	EZ1	LP840	N100
Series	Lumens ¹		Driver	Color temperature	Lumen management
WL4 4' wall-mount LED	20L 2000 lumens 30L 3000 lumens 40L 4000 lumens	(blank) MVOLT (120 - 277V) 347 347V	EZ1 eldoLED dims to 1%, 0-10V EZB eldoLED dims to dark, 0-10V SLD Step-level dimming ⁸	LP830 3000 K LP835 3500 K LP840 4000 K LP850 5000 K	(blank) No nLight N80 nLight with 80% lumen management N100 nLight without lumen management N80EMG nLight with 80% lumen management for use with generator supply emergency power N100EMG nLight without lumen management for use with generator supply emergency power

NESPDT7	DIM10	Options	Finish ¹¹
Occupancy control ¹	Standby mode ⁹		
NES7 Sensor Switch™ nES 7 PIR integral occupancy sensor ¹	(blank) Fixture turns off when unoccupied	EL7L LED Emergency battery pack (nominal 700 lumens); see Life Safety section ¹⁰	(blank) White
NESPDT7 Sensor Switch™ nES PDT 7 dual technology integral occupancy control ¹	DIM10 Fixture dims to approximately 10% light output when unoccupied	EL14L LED Emergency battery pack (nominal 1400 lumens); see Life Safety section ¹⁰	
NES7ADCX Sensor Switch™ nES 7 ADCX PIR integral occupancy sensor with automatic dimming control photocell ¹	DIMS0 Fixture dims to approximately 50% light output when unoccupied ⁹	SC Surface conduit end cap provisions	
XADS7 XPoint™ Wireless controller and micro 360° PIR occupancy and photocell sensor ^{1a}			
XADNS7 XPoint™ Wireless controller and micro 360° PIR occupancy and photocell sensor (egress lighting) ^{1a}			
MSD7 Sensor Switch™ MSD 7 PIR integral occupancy sensor ¹			

Notes

- 1 Approximate lumen output.
- 2 Not available with XPoint™ Wireless or nLight options.
- 3 See integral occupancy control section in header.
- 4 Requires N80 or N100.
- 5 Select (blank) under "Lumen management" for this option.
- 6 Gateway not included. Requires on-site commissioning. Visit www.lightingcontrols.com/XPointWireless for more information.
- 7 Not available with EZB or SLD.
- 8 Requires DIM10 or DIM50.
- 9 Requires occupancy control. For XPoint™ Wireless select (blank). Standby mode is programmed at time of commissioning.
- 10 Not available with 347V.
- 11 For additional paint finishes refer to Architectural Colors.



Project 15-20238-4
 MIAMI UNIVERSITY HAHNE HALL
 Submitted By
 KING LIGHTING INC

Catalog Number
 WL4 20L EZ1 LP840 N100 NESPD7 DIM10

Notes

Type

E

WL4 Wall Bracket & Surface Mount LED

Performance Data			
Lumen package	Input watts	Lumens	LPW
20L LP830	18.7	2050	110
20L LP835	18.7	2152	115
20L LP840	18.7	2255	121
20L LP850	18.7	2410	129
30L LP830	28.2	2952	105
30L LP835	28.2	3095	110
30L LP840	28.2	3251	115
30L LP850	28.2	3239	115
40L LP830	39.5	3927	99
40L LP835	39.5	4124	104
40L LP840	39.5	4325	110
40L LP850	39.5	4571	116

DIMENSIONS

All dimensions are inches (centimeters) unless otherwise noted.

Specifications

Length: with sensor - 50-15/16 (129.40)
 without sensor - 46-13/16 (118.90)
 Height: with sensor - 3-11/16 (9.3)
 without sensor - 3-7/8 (9.7)
 Width: 4-3/4 (12.1)

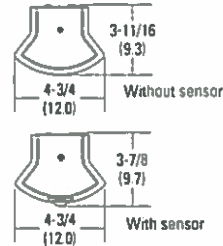

PHOTOMETRICS

WL4 30L EZ1 LP840, 3250.8 delivered lumens, test no. LTL25482P5, tested in accordance to IESNA LM-79

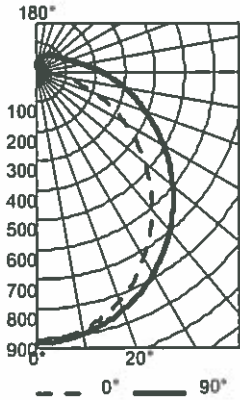

CP Summary

0°	90°
0°	912 912
5°	901 910
15°	856 879
25°	777 823
35°	666 745
45°	542 650
55°	412 549
65°	279 444
75°	151 346
85°	44 257
90°	5 219

Coefficients of Utilization

pf	20%					
	80%		70%		50%	
pc	70%	50%	30%	50%	30%	10%
0	116	116	116	112	112	112
1	104	99	94	95	91	87
2	94	85	78	82	75	70
3	85	74	66	72	64	57
4	78	66	56	63	55	48
5	72	58	49	57	48	42
6	66	52	43	51	42	36
7	61	47	39	46	38	32
8	57	43	35	42	34	28
9	53	40	31	39	31	25
10	50	37	29	36	28	23

Zonal Lumen Summary

Zone	Lumens	% Lamp	% Fixture
0° - 30°	701	21.6	21.6
0° - 40°	1143	35.2	35.2
0° - 60°	2032	62.5	62.5
0° - 90°	2829	87.0	87.0
90° - 120°	256	7.9	7.9
90° - 130°	310	9.5	9.5
90° - 150°	386	11.9	11.9
90° - 180°	421	13.0	13.0
0° - 180°	3251	100.0	100.0

MOUNTING DATA

For unit installation; surface ceiling or wall mounting.

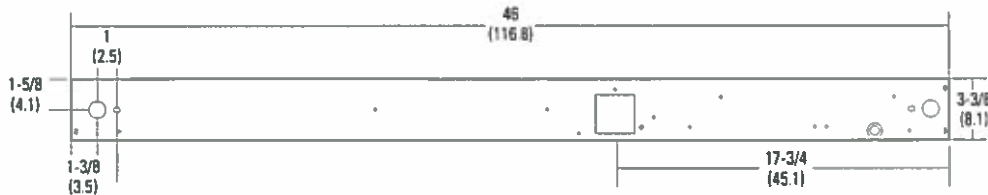

WL4-LED

LITHONIA LIGHTING

FEATURES & SPECIFICATIONS

INTENDED USE — Typical applications include corridors, lobbies, conference rooms and private offices.
CONSTRUCTION — 16-gauge galvanized steel mounting/plaster frame with trim clips to mount open conical shape reflector.

Vertically adjustable mounting brackets that use 16-gauge flat bar hangers (included), 1/2" conduit or C channel T-bar fasteners. Provides 3-3/4" total adjustment.

Post installation adjustment possible from above or below the ceiling.

Galvanized steel junction box with bottom-hinged access covers and spring latches. Two combination 1/2"-3/4" and three 1/2" knockouts for straight-through conduit runs. Capacity: 8 (4 in, 4 out) No. 12 AWG conductors, rated for 90°C.

Secondary housing adjustment system for precise, final ceiling-to-flange alignment.

Maximum 1-1/2" ceiling thickness.

OPTICS — LED light source with diffused lens, recessed in a deep reflector with a 55-degree cutoff. Aluminum full reflectors are optically designed to maximize lumen output and to provide superior glare control. Anodized trim colors for open and wallwash reflectors are available in clear, pewter, wheat or gold. White polyester powder coat also available.

Minimum CRI of 80.

ELECTRICAL — High-efficiency, eldoLED 0-10V dimming driver mounted to the junction box, dims luminaire to 10% of its light output. 1% dimming option available (see EZ1 ordering options below).

Dimming fixture requires two (2) additional low-voltage wires to be pulled.

For compatible dimmers and dimming range, refer to Dimmer Compatibility Chart on page 4.

The system maintains 70% lumen output for more than 50,000 hours.

LISTINGS — CSA certified to US and Canadian safety standards. Open downlight (LO6): Wet location listed. Wallwash downlight (LW6): Rated for damp and dry locations only. ENERGY STAR® certified.

WARRANTY — 5-year limited warranty. Complete warranty terms located at

www.aaculitybrands.com/CustomerResources/terms_and_conditions.aspx

Note: Specifications subject to change without notice.



LDN6 35/15 LO6AR 120

LDN6

6" OPEN and WALLWASH LED
 Non-IC
 New Construction Downlight

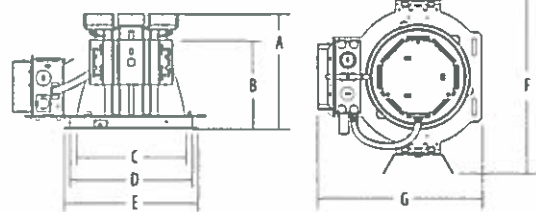

Overall height varies by lumen package. Reference dimension chart for details.

Maximum Overall Dimensions — All dimensions are inches (centimeters) unless otherwise indicated.							
Lumen package	(A) Height	(B) Frame height	(C) Aperture	(D) Ceiling opening	(E) Outside diameter	(F) Width	(G) Length
600 lm	6-7/16 (16.4)	5-3/4 (14.6)	6-15/16 (17.6)	7-1/8 (18.1)	7-1/2 (19.1)	12-15/16 (32.8)	10-15/16 (27.8)
1000 lm							
1500 lm							
2000 lm	7-13/16 (19.9)						

ORDERING INFORMATION Lead times will vary depending on options selected. Consult with your sales representative. Example: LDN6 35/15 LO6AR 120

LDN6 Series	40/06		LOGAR				VOLTS	Options
	Color temperature	Lumens ^{1,2}	Reflector	Trim color	Finish	Voltage		
LDN6	27/ 2700 K	06 600 lumens 10 1000 lumens 15 1500 lumens 20 2000 lumens	LO6 Open downlight LW6 Wallwash downlight ⁴	AR Clear	(blank) Semi-specular LD Matte-diffuse LS Specular	120 277 347 ¹	EL Emergency battery pack with integral test switch ⁴	
	30/ 3000 K			PR Pewter			ELR Emergency battery pack with remote test switch ⁴	
	35/ 3500 K			WTR Wheat			SF Single fuse	
	40/ 4000 K			GR Gold			TRW White painted flange ⁷	
			WR White ⁴			TRBL Black painted flange		
						NPS80EZ nLight® dimming pack controls 0-10V eldoLED drivers. Refer to TN-633 .		
						NPS80EZER nLight® dimming pack controls 0-10V eldoLED drivers. ER controls fixtures on emergency circuit. Refer to TN-633 . ⁴		
						RRL RELOC®-ready luminaire connectors enables a simple and consistent factory installed option across all ABL luminaire brands. Refer to RRL for complete nomenclature.		
						EZ1 eldoLED dims to 1%		
						CP Chicago plenum ^{1,5}		

Accessories: Order as separate catalog number.

EAC ISSM 325	Compact interruptible emergency AC power system
EAC ISSM 325	Compact interruptible emergency AC power system
GRA68 JZ	Oversized trim ring with 8" outside diameter ¹⁰
SCA6	Sloped ceiling adapter. Refer to TECH-SCA for more options.

- Notes**
- Approximate lumen output.
 - Overall height varies by lumen package. Reference dimension chart on page 1.
 - Rated for damp and dry locations only.
 - Not available with finishes.
 - Not available with emergency options.
 - For dimensional changes, refer to chart on page 4. Not available with CP option.
 - Not available with WR (white trim color).
 - For use with generator supply EM power. Will require an emergency hot feed and normal hot feed.
 - 277 volt CP products require marked spacing. Install with minimal spacing between: (a) Center-to-center of adjacent luminaires: 2 ft.; (b) Top of luminaire to overhead building member: 3 in.; (c) Luminaire center to side of building member: 1 ft.
 - Refer to [TECH-CODE RINGS](#) for more options.



Project 15-20238-4
 MIAMI UNIVERSITY HAHNE HALL
 Submitted By
 KING LIGHTING INC

Catalog Number
 LDN6 40/06 LO6AR VOLTS

Notes

Type

G

LDN6

PHOTOMETRY

Distribution Curve Distribution Data Output Data Coefficient of Utilization Illuminance Data at 30° Above Floor for a Single Luminaire

LDN6 35/10 LO6AR 120, input watts: 18, delivered lumens: 1089, LM/W = 61, spacing criterion at 0 = 1.03, test no. LTL25148SL.

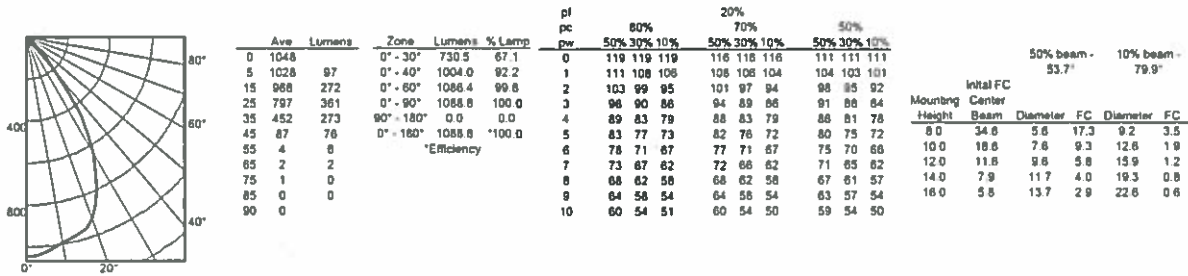

LDN6 35/15 LO6AR 120, input watts: 26, delivered lumens: 1633, LM/W = 63, spacing criterion at 0 = 1.03, test no. LTL25146.

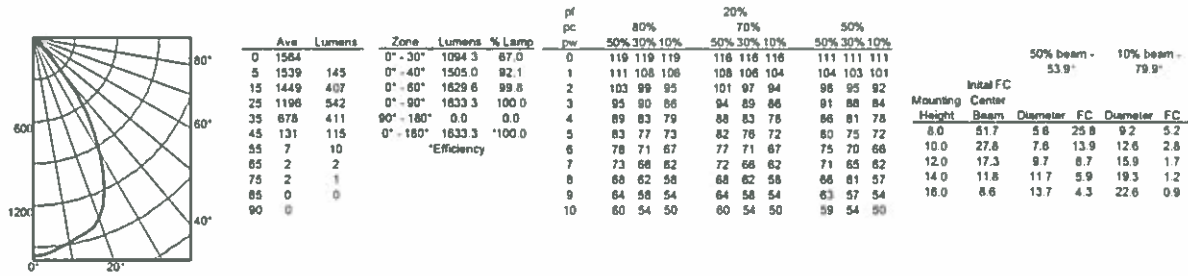

LDN6 35/20 LO6AR 120, input watts: 35, delivered lumens: 2143, LM/W = 61, spacing criterion at 0 = 1.04, test no. LTL25144.

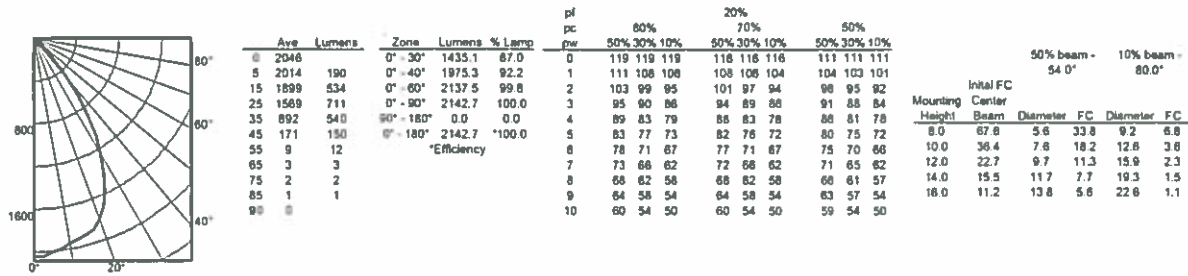

Notes

- Tested in accordance with IESNA LM-79-08.
- Tested to current IES and NEMA standards under stabilized laboratory conditions.
- Actual performance may differ as a result of end-user environment and application.
- Actual wattage may differ by +/- 10% when operating between 120-277V +/- 10%.
- CRI: 80 typical.



LDN6



Project 15-20238-4
MIAMI UNIVERSITY HAHNE HALL

Submitted By
KING LIGHTING INC

Catalog Number
LDN6 40/06 LO6AR VOLTS

Notes

Type

G

LDN6

TECHNICAL INFORMATION

Footcandle values are initial and tables are based on minimum of six units. For fixture to-wall distance other than those shown, use maximum of one-to-one spacing (distance between fixtures not more than distance to wall) for best results.

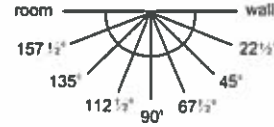

Candlepower Data

Footcandle values

LDN6 35/10 LW6AR 120, input watts: 18, delivered lumens: 1090, LM/W = 61, test no. LTL25147.

Vertical Angle	Plane angle							
	Wall	22.5	45	67.5	90	112.5	135	157.5
0	868	888	888	888	888	888	888	888
5	813	811	824	854	875	902	922	926
15	652	675	728	803	862	905	930	935
25	488	524	601	678	723	748	749	741
35	319	355	387	414	409	407	409	403
45	241	229	190	139	87	76	76	74
55	181	172	114	40	9	5	7	8
65	139	117	57	11	1	2	3	4
75	74	57	19	3	2	2	3	2
85	19	13	0	0	0	0	0	0
90	5	8	0	0	0	0	0	0

ft. from ceiling	Wallwash Illuminance Study (fc)								
	Luminaire mounted 3 ft. from wall			Luminaire mounted 3 ft. from wall			Luminaire mounted 3 ft. from wall		
	3 ft. between luminaires	4 ft. between luminaires	5 ft. between luminaires	3 ft. between luminaires	4 ft. between luminaires	5 ft. between luminaires	3 ft. between luminaires	4 ft. between luminaires	5 ft. between luminaires
1	10	8	10	9	5	9	9	2	9
2	15	15	15	13	10	13	12	6	12
3	15	14	15	12	10	12	10	7	10
4	13	14	13	10	11	10	8	8	8
5	12	13	12	9	10	9	7	8	7
6	12	12	12	8	9	8	7	7	7
7	10	10	10	8	8	8	6	6	6
8	9	9	9	7	7	7	5	5	5
9	8	8	8	6	6	6	5	5	5
10	6	6	6	5	5	5	4	4	4

LDN6 35/15 LW6AR 120, input watts: 26, delivered lumens: 1639, LM/W = 63, test no. LTL25145.

Vertical Angle	Plane angle							
	Wall	22.5	45	67.5	90	112.5	135	157.5
0	1312	1312	1312	1312	1312	1312	1312	1312
5	1198	1187	1202	1244	1265	1326	1371	1409
15	956	976	1052	1153	1246	1333	1403	1438
25	697	720	837	953	1026	1082	1109	1126
35	442	482	548	586	583	590	612	623
45	348	336	303	222	132	105	112	115
55	283	269	196	80	19	8	10	11
65	230	191	102	22	3	2	3	6
75	121	88	30	1	1	1	1	4
85	30	18	1	1	0	0	0	0
90	5	6	0	2	1	1	1	0

ft. from ceiling	Wallwash Illuminance Study (fc)								
	Luminaire mounted 3 ft. from wall			Luminaire mounted 3 ft. from wall			Luminaire mounted 3 ft. from wall		
	3 ft. between luminaires	4 ft. between luminaires	5 ft. between luminaires	3 ft. between luminaires	4 ft. between luminaires	5 ft. between luminaires	3 ft. between luminaires	4 ft. between luminaires	5 ft. between luminaires
1	17	13	17	16	7	16	15	4	15
2	24	24	24	20	16	20	19	10	19
3	22	22	22	17	16	17	15	11	15
4	20	21	20	14	16	14	12	12	12
5	18	19	18	13	15	13	10	12	10
6	17	17	17	12	13	12	9	11	9
7	15	15	15	11	11	11	9	9	9
8	13	13	13	10	10	10	8	8	8
9	11	11	11	8	8	8	7	7	7
10	9	9	9	7	7	7	6	6	6

LDN6 35/20 LW6AR 120, input watts: 35, delivered lumens: 2137, LM/W = 61, test no. LTL25143.

Vertical Angle	Plane angle							
	Wall	22.5	45	67.5	90	112.5	135	157.5
0	1712	1712	1712	1712	1712	1712	1712	1712
5	1566	1544	1598	1633	1710	1739	1783	1858
15	1254	1278	1394	1533	1658	1755	1811	1834
25	913	956	1140	1307	1420	1489	1512	1521
35	592	654	768	839	851	852	855	861
45	448	425	402	325	215	170	167	167
55	335	317	248	115	32	13	12	14
65	251	213	129	35	5	4	5	5
75	121	92	39	4	1	1	1	3
85	24	14	2	0	1	0	0	0
90	1	1	1	0	1	1	1	0

ft. from ceiling	Wallwash Illuminance Study (fc)								
	Luminaire mounted 3 ft. from wall			Luminaire mounted 3 ft. from wall			Luminaire mounted 3 ft. from wall		
	3 ft. between luminaires	4 ft. between luminaires	5 ft. between luminaires	3 ft. between luminaires	4 ft. between luminaires	5 ft. between luminaires	3 ft. between luminaires	4 ft. between luminaires	5 ft. between luminaires
1	17	13	17	16	7	16	16	4	16
2	28	27	28	23	18	23	22	11	22
3	28	27	28	22	19	22	19	14	19
4	26	27	26	19	20	19	16	15	16
5	24	25	24	17	20	17	13	16	13
6	22	22	22	16	17	16	12	15	12
7	20	20	20	15	15	15	11	13	11
8	17	17	17	13	13	13	10	11	10
9	15	15	15	11	11	11	9	9	9
10	13	13	12	10	10	10	8	8	8

Notes

- Tested in accordance with IESNA LM-79-08.
- Tested to current IES and NEMA standards under stabilized laboratory conditions.
- Actual performance may differ as a result of end-user environment and application.
- Actual wattage may differ by +/- 10% when operating between 120-277V +/- 10%.
- CRI: 80 typical.



LDN6

LDN6

ADDITIONAL DATA

DIMMER COMPATIBILITY CHART	
Manufacturer	Model/Series
600 & 1000 Lumen products	
Leviton	IlumaTech - IP710-DLX
Lutron	Nova T - NTFTV-WH <i>For on/off control, this switch requires a power pack. Consult Lutron for more information.</i>
Sensor Switch	nPODM DX
Synergy	ISD BC 120/277
1500 & 2000 Lumen products	
Busch-Jaeger	2112U-101
Jung	240-10
Leviton Lighting Controls	IlumaTech - IP710-DLX
Lightoller Controls	ZP600FAM120
Lutron Electronics	Nova T - NTFTV
	Divva - DVTV
	Divva - NFTV
	GraphicEye - GRX-TVI w GRX3503
	Energy Savr Node - QSN-4T16-S
TVM2 Module	
Merten	5729
Pass & Seymour	CD4FB-W
Sensor Switch	nPODM DX
Synergy	ISD BC 120/277
The Watt Stopper	DCLV1

EL/ELR DIMENSIONAL CHANGES	
Add to overall housing length for EL/ELR option	Overall housing width with EL/ELR option
4-1/2	16-1/2

EL/ELR AVAILABILITY/COMPATIBILITY - INITIAL LUMENS			
Lumen package	Watts	Initial lumens EL/ELR	Emergency LED driver
600	12	500	PS1030
1000	18	575	PS1030
1500	26	640	Bodine BSL17C-C2
2000	35	690	Bodine BSL17C-C2

KEY SPECIFICATION SUMMARY				
Product Description	Watts (W)	Delivered lumens (lm)	Efficacy (lm/W)	Spacing criteria (s/mh)
LDN6 35/06 L06AR	12	670	56	1.03
LDN6 35/10 L06AR	18	1090	61	1.03
LDN6 35/15 L06AR	26	1640	63	1.03
LDN6 35/20 L06AR	35	2140	61	1.04

Choose Wall Controls.
 nLIGHT offers multiple styles of wall controls – each with varying features and user experience.



Push-Button WallPod
 Traditional tactile buttons and LED user feedback



Touch WallPod
 Contemporary capacitive touch style buttons with audible clicker for user feedback



Graphic WallPod
 Full color touch screen provides a sophisticated look and feel

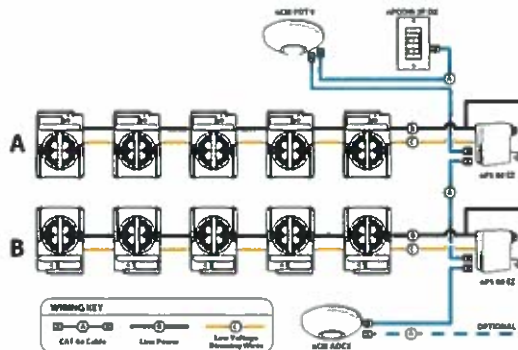

EXAMPLE

Group Fixture Control*

*Application diagram applies for fixtures with eldoLED drivers only

- nPS 80 E2 Dimming/Control Pack (qty 2 required)
- nPODM 2P DX Dual On/Off/Dim Push-Button WallPod
- nCM ADCX Daylight Sensor with Automatic Dimming Control
- nCM PDT 9 Dual Technology Occupancy Sensor

Description: This design provides a dual on/off/dim wall station that enables manual control of the fixtures in Row A and Row B separately. Additionally, a daylight harvesting sensor is provided so the lights in row B can be configured to dim automatically when daylight is available. An occupancy sensor turns off all lights when the space is vacant.

**PHILIPS
LIGHTOLIER**

Downlighting

SlimSurface LED

5" and 7" round aperture
surface mount downlight

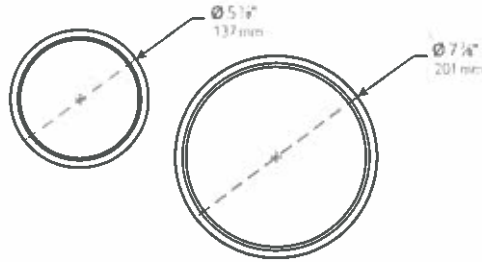

Specifiers will enjoy the appearance and the accolades of selecting a product that meets and exceeds the needs of their customers. Contractors will have a positive experience working with a hassle-free downlight installation.

Project	
Location	
Cat No	
Type	
Lamps	Qty
Notes	

Round 5" aperture

Catalog No.	Size	CRI	CCT	Lms	Listed	Finish (painted)
S5R827K7	5-inch	80	2700K	650	Wet	White
S5R827K7AL	5-inch	80	2700K	650	Wet	Aluminum
S5R830K7	5-inch	80	3000K	650	Wet	White
S5R830K7AL	5-inch	80	3000K	650	Wet	Aluminum
S5R927K7	5-inch	90	2700K	650	Wet	White
S5R927K7AL	5-inch	90	2700K	650	Wet	Aluminum
S5R830K7-D	5-inch	80	3000K	650	Damp	White

Round 7" aperture

Catalog No.	Size	CRI	CCT	Lms	Listed	Finish (painted)
S7R827K10	7-inch	80	2700K	1000	Wet	White
S7R827K10AL	7-inch	80	2700K	1000	Wet	Aluminum
S7R830K10	7-inch	80	3000K	1000	Wet	White
S7R830K10AL	7-inch	80	3000K	1000	Wet	Aluminum
S7R927K10	7-inch	90	2700K	1000	Wet	White
S7R927K10AL	7-inch	90	2700K	1000	Wet	Aluminum
S7R830K10-D	7-inch	80	3000K	1000	Damp	White

Features

- Flange:** One piece plastic flange. Powder coated non yellowing white or aluminum.
- Lens:** High transmittance lens allowing for smooth, comfortable light pattern.
- Power supply:** Integral class 2 driver. Factory wired electronic LED driver (see Electrical section for specifications)
- LED Strip:** Utilizes Philips LEDs.
- Lifetime:** Expected lifetime 50,000 hours and backed by a 5-year warranty (see Philips.com/warranties for details).

Electrical

Electronic power supply: RoHS compliant. Class 2 power unit for use in a damp location. Unit tolerates sustained open circuit and short circuit output conditions without damage.

Dimming: All luminaires are intended for use with incandescent standard type dimmers (TRIAC). 10%-100% dimming range.

Lumen Output	Max. Input Current	Max. Input Power
630lm	0.08A	9.5W
980lm	0.13A	14.2W

Input Voltage 120V
Input Frequency 50/60Hz
Power Factor > 0.9
Max. THD < 15%
Minimum Operating Temperature - 20°C

Compatibility

Installs into standard J-box applications:

-  3 1/2" round (plastic)
-  4" square (plastic)
Not compatible with S5R
-  4" octagonal (metal)
-  4" square (metal)
Not compatible with S5R

Labels

cULus listed for damp locations (walls) and wet locations (ceilings). ENERGY STAR® certified.

Non-conductive fixture for shower light application. This product complies with the requirements of the California Energy Commission regulated under Title 24, and has been listed in the Title 20 database.



S5R & S7R SlimSurface LED

5" and 7" round aperture surface mount downlight

Dimensions

SlimSurface LED 5" downlight

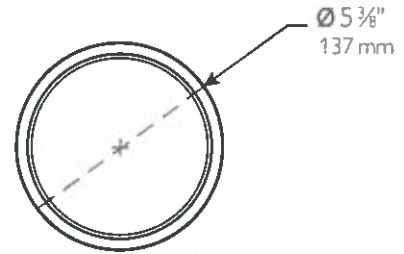
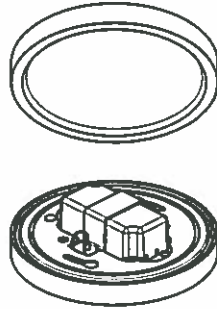
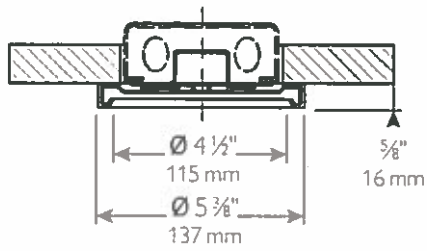

SlimSurface LED 7" downlight

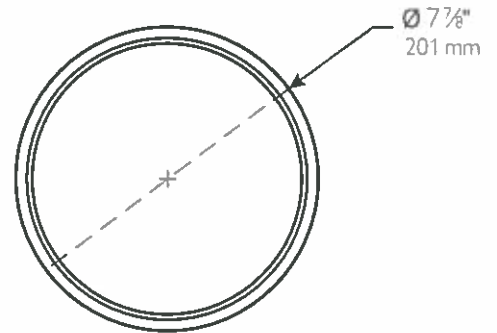
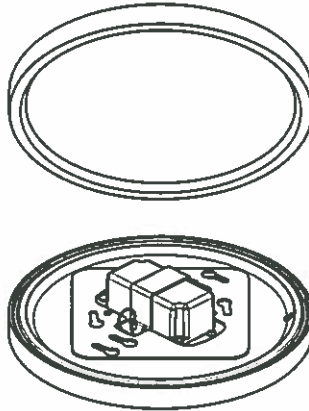
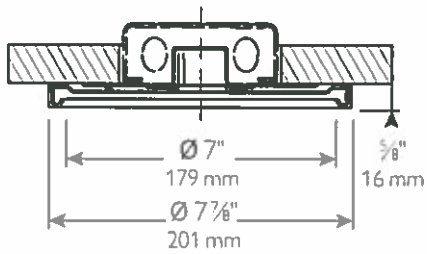

S5R & S7R SlimSurface LED

5" and 7" round aperture surface mount downlight

S5R830K7 • 10W LED, 3000K, 80 CRI, 650lm

Candela Curves		Angle	Mean CP	Lumens
		0	294	
		5	291	
		10	286	
		15	282	80
		20	276	
		25	265	
		30	253	122
		35	236	
		40	211	
		45	157	121
		50	108	
		55	74	68
		60	53	
		65	39	40
		70	30	
		75	22	23
		80	14	
		85	5	6
		90	0	

Report ¹ 438GFR		Input Watts ²	9.8W
Output lumens	625lms	Efficacy	64.8lm/w
Spacing Criterion	13	CCT ³	3000K
Field Angle	141°	CRI	>80
Beam Angle	92°		

Single unit data		
Height to Lighted Plane	Initial center beam foot-candles	Beam dia. (ft)*
5'	12	6.5'
6'	8	7.8'
7'	6	9.1'
8'	5	10.4'
9'	4	11.7'

* Beam diameter is where foot-candles drop to 50% of maximum

Multiple unit data - RCR 2		
Spacing on center	Initial center beam foot-candles	Watts per sq ft
5'	26.7	0.43
6'	17.5	0.29
7'	12.5	0.20
8'	10.4	0.17
9'	8.4	0.14

Coefficients of utilization

Ceiling	80%				70%		50%		30%		0%	
	70	50	30	10	50	10	50	10	50	10	0	
Wall												
RCR	Zonal cavity method - Effective floor reflectance = 20%											
Room Cavity Ratio	0	119	119	119	119	116	116	111	111	106	106	100
	1	111	107	103	100	104	98	100	95	96	92	87
	2	102	95	89	84	93	83	90	81	87	80	76
	3	94	85	78	72	84	72	81	71	78	69	66
	4	87	77	69	63	75	63	73	62	71	61	58
	5	81	69	61	55	68	55	66	55	64	54	52
	6	75	63	55	49	62	49	61	49	59	48	46
	7	70	58	50	44	57	44	55	44	54	43	41
	8	65	53	45	40	52	40	51	39	50	39	37
	9	61	49	41	36	48	36	47	36	46	36	34
	10	58	45	38	33	45	33	44	33	43	33	31

Zonal lumens & percentages

Zone	Lumens	%Luminaire
0-30	230	36.2%
0-40	377	59.3%
0-60	566	89.2%
0-90	635	100.0%

S7R830K10 • 14W LED, 3000K, 80 CRI, 1000lm

Candela Curves		Angle	Mean CP	Lumens
		0	461	
		5	457	
		10	450	
		15	444	125
		20	433	
		25	415	
		30	395	192
		35	365	
		40	322	227
		45	235	182
		50	161	
		55	111	102
		60	80	
		65	59	60
		70	45	
		75	34	36
		80	22	
		85	10	11
		90	0	

Report ¹ 441GFR		Input Watts ²	13.8W
Output lumens	977lms	Efficacy	70.8lm/w
Spacing Criterion	13	CCT ³	3000K
Field Angle	140°	CRI	>80
Beam Angle	91°		

Single unit data		
Height to Lighted Plane	Initial center beam foot-candles	Beam dia. (ft)*
5'	18	6.5'
6'	13	7.8'
7'	9	9.1'
8'	7	10.4'
9'	6	11.7'

* Beam diameter is where foot-candles drop to 50% of maximum

Multiple unit data - RCR 2		
Spacing on center	Initial center beam foot-candles	Watts per sq ft
5'	41.2	0.61
6'	27.0	0.40
7'	19.3	0.29
8'	16.1	0.24
9'	12.9	0.19

Coefficients of utilization

Ceiling	80%				70%		50%		30%		0%	
	70	50	30	10	50	10	50	10	50	10	0	
Wall												
RCR	Zonal cavity method - Effective floor reflectance = 20%											
Room Cavity Ratio	0	119	119	119	119	116	116	111	111	106	106	100
	1	111	107	103	100	104	98	100	95	96	92	87
	2	102	95	89	84	93	83	90	82	87	80	76
	3	94	85	78	73	84	72	81	71	78	70	66
	4	87	77	69	63	76	63	73	62	71	61	59
	5	81	70	62	56	69	56	67	55	65	54	52
	6	75	63	55	50	63	49	61	49	59	49	46
	7	70	58	50	44	57	44	56	44	54	44	42
	8	66	53	46	40	53	40	51	40	50	40	38
	9	62	49	42	36	49	36	48	36	47	36	34
	10	58	46	38	33	45	33	44	33	43	33	31

Zonal lumens & percentages

Zone	Lumens	%Luminaire
0-30	360	36.9%
0-40	587	60.1%
0-60	871	89.2%
0-90	977	100.0%

1 Tested using absolute photometry as specified in LM79 IESNA Approved Method for the Electrical and Photometric Measurements of Solid-State Lighting Products
 2 Wattage controlled to within 5%
 3 Correlated Color Temperature within specs as defined in ANSI, NEMA, ANSLG C78 377-2008 Specifications for the Chromaticity of Solid State Lighting Products





Project 15-20238-4
MIAMI UNIVERSITY HAHNE HALL

Submitted By
KING LIGHTING INC

Catalog Number
2VTL2 20L ADP SLD LP830

Notes

Type

H



FEATURES & SPECIFICATIONS

INTENDED USE — The VT Series Volumetric LED Troffer (VTL) combines the aesthetics and high performance with intelligent LED engines for applications - offices, schools, retail locations and hospitals. High-efficiency light engine delivers long life and excellent color, ensuring a superior quality lighting installation that is highly efficient and sustainable. Multiple lumen packages and driver options provide solutions for all your lighting applications. Featured nLight controls system provides design flexibility and ease of installation and optimum energy savings.

CONSTRUCTION — Rugged, one-piece cold-rolled steel coated polyester, painted after fabrication with embossed facets. Impact-modified, single clear acrylic diffuser provides excellent shielding and wide distribution. End plates include integral T-bar clips. Fixture may be mounted and wired in continuous rows. Total fixture height is only 4-3/8".

OPTICS — Volumetric illumination is achieved by creating an optimal mix of light to walls, partitions, vertical and horizontal work surfaces — rendering the interior space, objects and occupants in a more balanced, complementary luminous environment. Linear faceted reflector cavity softens and distributes light into the space while minimizing luminous contrast between the fixture and ceiling. Sloped end plates provide a smooth, luminous transition between fixture and ceiling while enhancing the perception of fixture depth. High-performance diffuser provides LED concealment, even illumination across the diffuser and improved lumen-per-watt performance.

ELECTRICAL — Long-life LEDs, coupled with high-efficiency drivers, provide superior quantity and quality of illumination for extended service life, 90% LED lumen maintenance at 60,000 hours (L90/60,000). eidoLED driver options deliver choice of dimming range, and choices for control, while assuring flicker-free, low-current inrush, 89% efficiency and low EMI.

Optional integrated nLight® controls make each luminaire addressable - allowing it to digitally communicate with other nLight enabled controls such as dimmers, switches, occupancy sensors and photocontrols. Simply connect all the nLight enabled control devices and the VTL LED luminaires using standard Cat-5 cabling. Unique plug-and-play convenience as devices and luminaires automatically discover each other and self-commission.

Lumen Management: Unique lumen management system (option N80) provides onboard intelligence that actively manages the LED light source so that constant lumen output is maintained over the system life, preventing the energy waste created by the traditional practice of over-lighting.

Step-level dimming option allows system to be switched to 50% power for compliance with common energy codes while maintaining fixture appearance.

Driver disconnect provided where required to comply with US and Canadian codes.

INSTALLATION — Unique grid interfacing arrangement provides mounting into standard 1" and 9/16" tee bar or screw slot grids. 9/16" allows fixture trim to hang level with architectural ceiling tiles. Drywall ceiling adaptors available. Suitable for damp location.



LISTINGS — CSA Certified to meet U.S. and Canadian standards. IC rated. DesignLights Consortium® (DLC) qualified product. Not all versions of this product may be DLC qualified. Please check the DLC Qualified Products List at www.designlights.org/DPL to confirm which versions are qualified.

WARRANTY — 5-year limited warranty. Complete warranty terms located at www.aculitybrands.com/CustomersResources/Terms_and_conditions.aspx. Actual performance may differ as a result of end-user environment and application. Note: Specifications subject to change without notice.

ORDERING INFORMATION

Lead times will vary depending on options selected. Consult with your sales representative.

Example: 2VTL2 33L ADP EZ1 LP835 N100

2VTL2		20L	ADP		SLD	LP830		
Series	Air function	Lumens	Diffuser	Voltage	Driver ¹	Color temperature	Controls ⁴	Options
2VTL2 2X2 VTL	(blank) Static H Heat removal	20L 2000 ¹ 33L 3300 ¹ 40L 4000 ¹	ADP Acrylic linear prismatic	(blank) MVOLT 347 347 ²	EZ1 eidoLED dims to 1% (0-10 volt dimming) EZB eidoLED dims to black (0-10 volt dimming) EDB eidoLED DALI ³ EXB eidoLED DMX/RDM ⁴ SLD Step-level dimming ⁵ EXA1 Dims to 1%, XPoint wireless enabled ⁶ EXAB Dims to dark, XPoint wireless enabled ⁶	LP830 82CRI, 3000 K LP835 82CRI, 3500 K LP840 82CRI, 4000 K LP850 82CRI, 5000 K	(blank) No controls N80 nLight ⁷ with 80% lumen management N80EMG nLight ⁷ with 80% lumen management For use with generator supply EM power N100 nLight ⁷ without lumen management N100EMG nLight ⁷ without lumen management For use with generator supply EM power	EL7L 700 lumen battery pack EL14L 1400 lumen battery pack CP Chicago plenum

Performance Data			
Lumen Package	Lumens	Input Watts ¹	LPW
20L	2000 - 2400	20	100 - 117
33L	3350 - 3900	34.5	98 - 113
40L	3900 - 4550	41.5	95 - 109

Accessories: Order as separate catalog numbers.	
2VTZ F916	Trim to adjust fixture mounting flush with 9/16" T-bar; for 2x2 fixture
DGA22	Drywall ceiling adaptor, unit installation ⁷

Notes

- 1 Approximate lumen output.
- 2 Consult factory for availability. Not available with SLD, EL7L or EL14 battery packs.
- 3 Actual wattage may differ by +/- 5% when operating between 120-277V +/- 10%.
- 4 Not available with N80, N80EMG, N100 or N100EMG.
- 5 Gateway not included. Requires on-site commissioning. Visit www.lightcontrols.com/XPPointWireless for more information.
- 6 nLO access limitations with 20L or EZB.
- 7 When DGA kits are used, order 2VTZ F916 accessory.



Project 15-20238-4
MIAMI UNIVERSITY HAHNE HALL

Submitted By
KING LIGHTING INC

Catalog Number
2VTL2 20L ADP SLD LP830

Notes

Type

H

2VTL Volumetric Recessed Lighting 2'x2'

PHOTOMETRICS

2VTL2 20L ADP LP835, 2196 delivered lumens, test no. LTL24790P, tested in accordance to IESNA LM-79

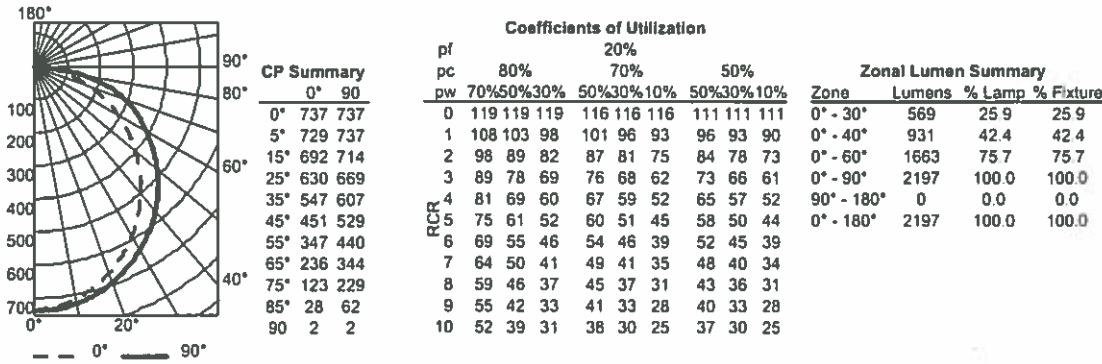

2VTL2 33L ADP L835, 3564 delivered lumens, test no. LTL24790P4, tested in accordance to IESNA LM-79

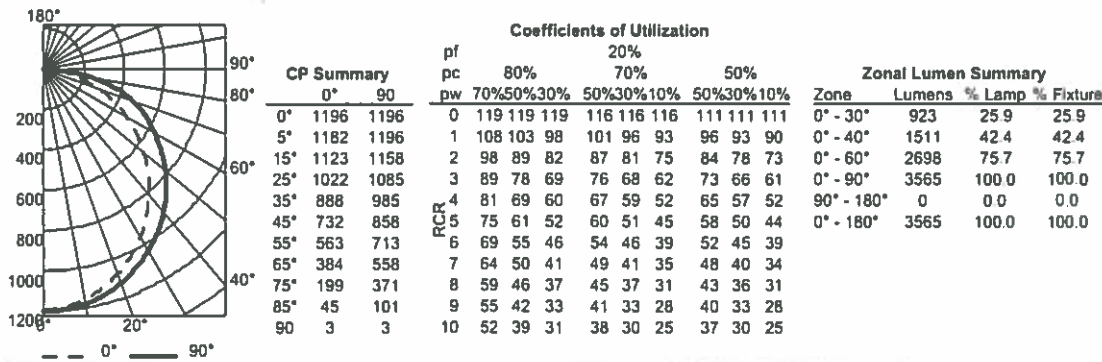

Mounting Data

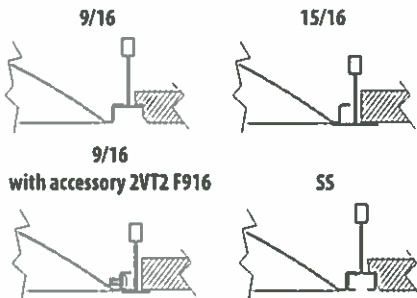

nLight® Control Accessories:

Order as separate catalog number. Visit www.sensorswitch.com/nLight for complete listing of nLight controls.

WallPod stations	Model number	Occupancy sensors	Model number
On/Off	nPODM (color)	Small motion 360°, ceiling (PIR / dual tech)	nCM 9 / nCM PDT 9
On/Off & Raise/Lower	nPODM DX (color)	Large motion 360°, ceiling (PIR / dual tech)	nCM 10 / nCM PDT 10
Graphic Touchscreen	nPOD GFX	Wall switch with raise/lower	nWSXPDTLVDX
Photocell controls	Model number	Cat-5 cable bundles (plenum rated)	Model number
On/Off & Dimming	nCM ADCX	10', 15 pieces per bundle	CATS 10FT
		30', 15 pieces per bundle	CATS 30FT

Dimensions

All dimensions are inches (centimeters) unless otherwise specified.

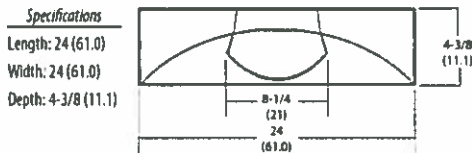

Constant Lumen Management

Enabled by the embedded nLight control, the VTL2 actively tracks its run-time and manages its light source such that constant lumen output is maintained over the system life. Referred to as lumen management, this feature eliminates the energy waste created by the traditional practice of over-lighting.

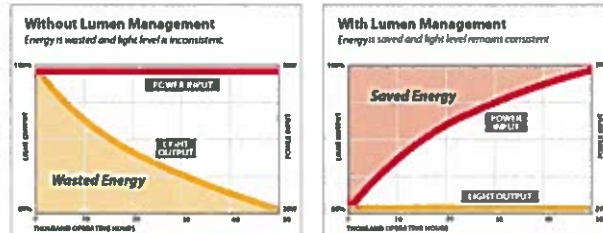

2VTL-2X2

LITHONIA LIGHTING®

FEATURES & SPECIFICATIONS

INTENDED USE — The VT Series Volumetric LED Troffer (VTL) combines the aesthetics and high performance with intelligent LED engines for applications - offices, schools, retail locations and hospitals. High-efficiency light engine delivers long life and excellent color, ensuring a superior quality lighting installation that is highly efficient and sustainable. Multiple lumen packages and driver options provide solutions for all your lighting applications. Featured nLight controls system provides design flexibility and ease of installation and optimum energy savings.

CONSTRUCTION — Rugged, one-piece cold-rolled steel coated polyester, painted after fabrication with embossed facets. Impact-modified, single clear acrylic diffuser provides excellent shielding and wide distribution. End plates include integral T-bar clips. Fixture may be mounted and wired in continuous rows. Total fixture height is only 4-3/8".

OPTICS — Volumetric illumination is achieved by creating an optimal mix of light to walls, partitions, vertical and horizontal work surfaces — rendering the interior space, objects and occupants in a more balanced, complementary luminous environment. Linear faceted reflector cavity softens and distributes light into the space while minimizing luminous contrast between the fixture and ceiling. Sloped end plates provide a smooth, luminous transition between fixture and ceiling while enhancing the perception of fixture depth. High-performance diffuser provides LED concealment, even illumination across the diffuser and improved lumen-per-watt performance.

ELECTRICAL — Long-life LEDs, coupled with high-efficiency drivers, provide superior quantity and quality of illumination for extended service life. 90% LED lumen maintenance at 60,000 hours (L90/60,000).

eldoLED driver options deliver choice of dimming range, and choices for control, while assuring flicker-free, low-current inrush, 89% efficiency and low EMI.

Optional integrated nLight® controls make each luminaire addressable - allowing it to digitally communicate with other nLight enabled controls such as dimmers, switches, occupancy sensors and photocontrols. Simply connect all the nLight enabled control devices and the VTL LED luminaires using standard Cat-5 cabling. Unique plug-and-play convenience as devices and luminaires automatically discover each other and self-commission.

Lumen Management: Unique lumen management system (option N80) provides onboard intelligence that actively manages the LED light source so that constant lumen output is maintained over the system life, preventing the energy waste created by the traditional practice of over-lighting.

Step-level dimming option allows system to be switched to 50% power for compliance with common energy codes while maintaining fixture appearance.

Driver disconnect provided where required to comply with US and Canadian codes.

INSTALLATION — Unique grid interfacing arrangement provides mounting into standard 1" and 9/16" tee bar or screw slot grids. 9/16" allows fixture trim to hang level with architectural ceiling tiles. Drywall ceiling adaptors available. Suitable for damp location.

LISTINGS — CSA Certified to meet U.S. and Canadian standards. KC rated. DesignLights Consortium® (DLC) qualified product. Not all versions of this product may be DLC qualified. Please check the DLC Qualified Products List at www.designlights.org/DPL to confirm which versions are qualified.

VT LED

VT Series Volumetric LED Troffer

2VTL

2' x 4'
LED



eldoLED

INDUSTRY RECOGNITION/AWARDS



WARRANTY — 5-year limited warranty. Complete warranty terms located at www.acuitybrands.com/CustomerResources/Terms_and_conditions.aspx

Actual performance may differ as a result of end-user environment and application.

Note: Specifications subject to change without notice.

ORDERING INFORMATION

Lead times will vary depending on options selected. Consult with your sales representative.

Example: 2VTL4 48L ADP EZ1 LP835 N80

2VTL4	30L	ADP	EZ1	LP830	Options			
Series	Air function	Lumens	Diffuser	Voltage	Driver ¹	Color temperature	Controls ⁴	Options
→ 2VTL4 2X4 VTL	(blank) Static H Heat removal	30L 3000 ¹ 40L 4000 ¹ 48L 4800 ¹ 60L 6000 ¹ 72L 7200 ¹	ADP Acrylic linear prismatic	(blank) MVOLT 347 347 ²	EZ1 eldoLED dims to 1% (0-10 volt dimming) EZB eldoLED dims to black (0-10 volt dimming) EDB eldoLED DALI ³ EXB eldoLED DMX/RDM ³ SLD Step-level dimming ⁴ EXA1 Dims to 1%, XPoint wireless enabled ⁵ EXAB Dims to dark, XPoint wireless enabled ⁵	LP830 82CRI, 3000 K LP835 82CRI, 3500 K LP840 82CRI, 4000 K LP850 82CRI, 5000 K	(blank) No controls N80 night ⁶ with 80% lumen management N80EMG night ⁶ with 80% lumen management For use with generator supply EM power N100 night ⁶ without lumen management N100EMG night ⁶ without lumen management For use with generator supply EM power	EL7L 700 lumen battery pack EL14L 1400 lumen battery pack CP Chicago plenum

Performance Data

Lumen Package	Lumens	Input Watts ¹	LPW
30L	3150 - 3650	31	103 - 118
40L	4000 - 4600	39	102 - 117
48L	4600 - 5350	47	99 - 114
60L	5050 - 6250	52	97 - 119
72L	6750 - 7800	70	98 - 111

Accessories: Order as separate catalog number.

2VT4 F916	Trim to adjust fixture mounting flush with 9/16" T-bar; for 2x4 fixture
DGA24	Drywall ceiling adaptor, unit installation ⁷

Notes

- 1 Approximate lumen output.
- 2 Consult factory for availability. Not available with SLD, EL7L or EL14 battery packs.
- 3 Actual wattage may differ by +/- 5% when operating between 120-277V +/- 10%.
- 4 Not Available with N80, N80EMG, N100, or N100EMG.
- 5 Gateway not included. Requires on-site commissioning. Visit www.lithonia.com/XPointWireless for more information.
- 6 n10 access limitations on 30L or EZB.
- 7 When DGA kits are used, order 2VT4 F916 accessory



Project 15-20238-4
MIAMI UNIVERSITY HAHNE HALL

Submitted By
KING LIGHTING INC

Catalog Number
2VTL4 30L ADP EZ1 LP830

Notes

Type

H1

2VTL Volumetric Recessed Lighting 2'x4'

PHOTOMETRICS

2VTL4 40L ADP LP835, 4211 delivered lumens, test no. LTL24782P4, tested in accordance to IESNA LM-79

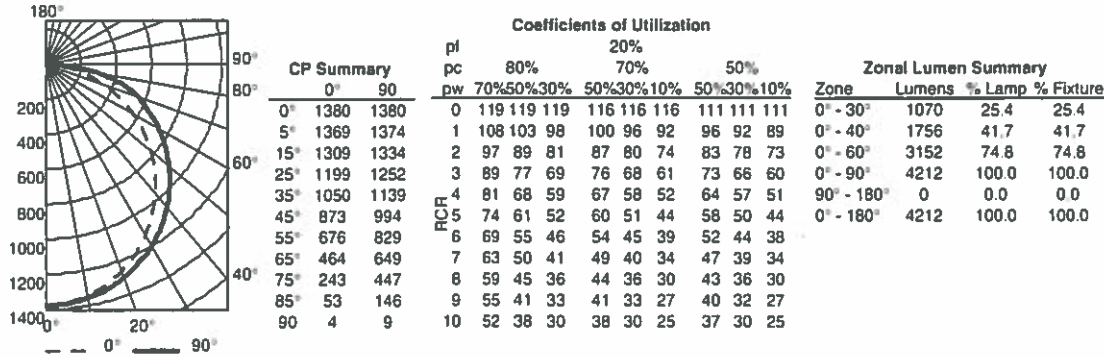

2VTL4 48L ADP LP835, 4879 delivered lumens, test no. LTL24782P8, tested in accordance to IESNA LM-79

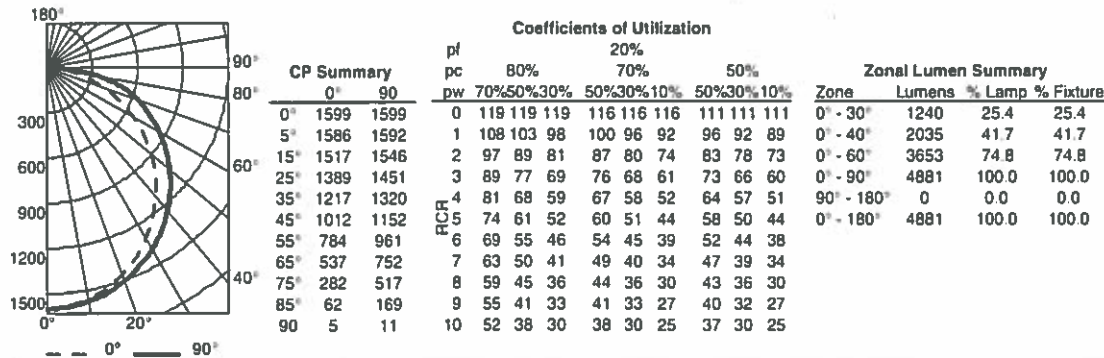

Mounting data

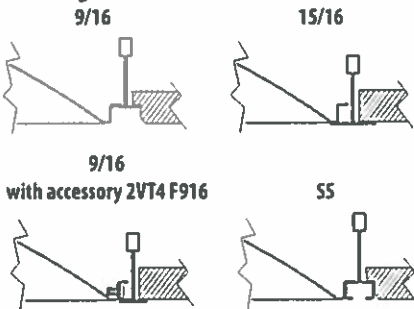

nLight® Control Accessories:
Order as separate catalog number. Visit www.sensorswitch.com/nLight for complete listing of nLight controls.

WallPod stations	Model number	Occupancy sensors	Model number
On/Off	nPDDM [color]	Small motion 360°, ceiling (PIR / dual tech)	nCM 9 / nCM PDT 9
On/Off & Raise/Lower	nPDDM DX [color]	Large motion 360°, ceiling (PIR / dual tech)	nCM 10 / nCM PDT 10
Graphic Touchscreen	nPOD GFX	Wall switch with raise/lower	nWSXPDTLVDX
Photocell controls	Model number	Cat-5 cable bundles (plenum rated)	Model number
On/Off & Dimming	nCM ADCX	10', 15 pieces per bundle	CATS 10FT
		30', 15 pieces per bundle	CATS 30FT

Dimensions

All dimensions are inches (centimeters) unless otherwise specified.

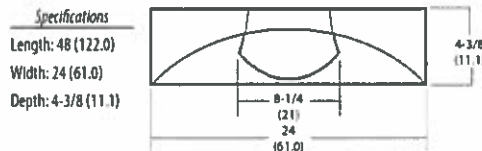

Constant Lumen Management

Enabled by the embedded nLight control, the VTL4 actively tracks its run-time and manages its light source such that constant lumen output is maintained over the system life. Referred to as lumen management, this feature eliminates the energy waste created by the traditional practice of over-lighting.

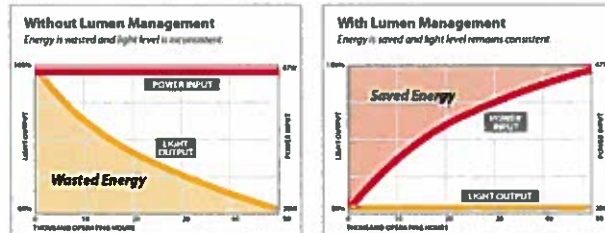

2VTL-2X4

Submitted by LEESMAN LIGHTING



Job Name:
Miami U - Hahne Hall - LEE15-23278

Catalog Number:
E2R-1T5-4-GXG-120-1C-W

Type:
H2

Notes:

LEE15-23278

EDGE 2R

LUMINOUS GEOMETRY™

1T5 Recessed Linear with
Straight Lamp / Regress Lens



Project Name _____ Date _____
Catalog Number _____ Type _____

CONSTRUCTION Formed cold rolled steel housing. Highly reflective die-formed white painted steel reflector. .070 diffuse acrylic lens with matte finish, continuous ripple pattern co-extruded acrylic white trim pattern unless otherwise specified. Co-extruded regress lens module is removable for lamp replacement and easily snaps back into housing.

ELECTRICAL Standard programmed start UL listed Class P, T5 electronic, sound rated A, thermally protected, high power factor ballasts less than 10% THD, universal voltage (120/277) with 50/60Hz operation. Through wiring with quick connects standard on Continuous Runs. Standard single circuit. Integral battery packs with remote test switch are provided with 1B option. Each ballast provided with disconnects to meet luminaire disconnect code requirement.

MOUNTING Edge is designed to install into acoustical grid and inaccessible ceilings. Specify GXG, FLF, SFS, NFN for individual, unjoinable units (individual units will fall on-grid). Specify GX, FL, SF, NF for continuous runs (runs designed to fall on-grid). Consult factory for detailed installation instructions.

FINISH Standard powder-coat textured white painted finish on exposed trim, consult factory for custom colors.

LABELS UL and cUL Listed, approved for dry/damp location unless otherwise noted.

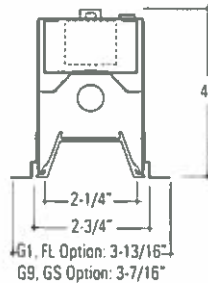

(1) Straight Lamp

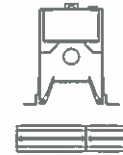

See Straight Lamp Guide for row configuration, wattage and number of lamps per row.

LUMINAIRE SPECIFICATION

Sample Catalog #: E2R-1T5-24'-FL-120-1C-W

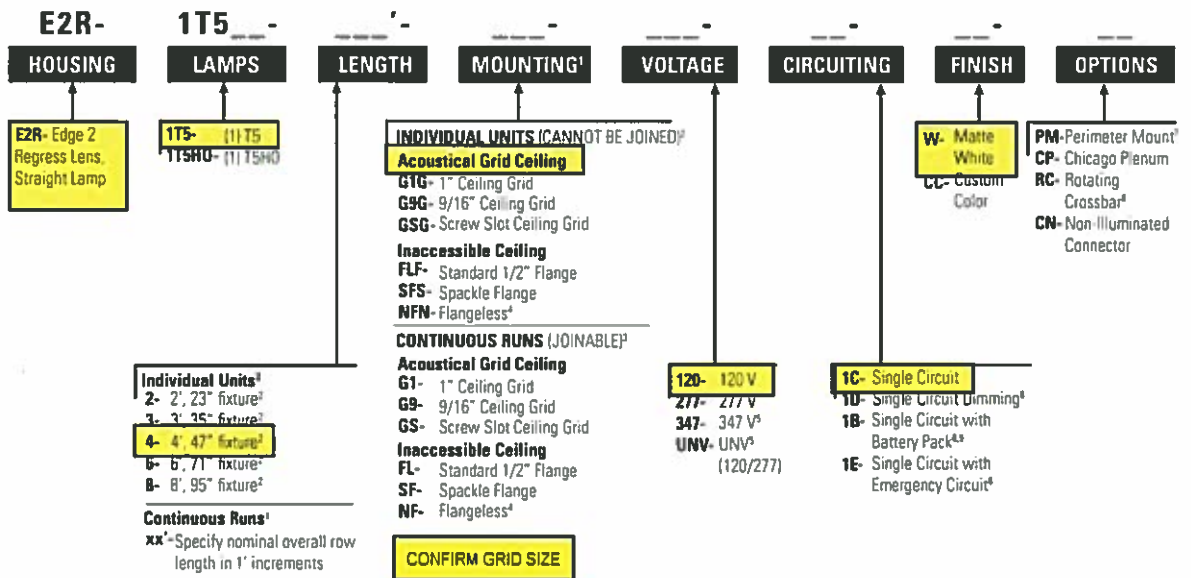

¹See back page for mounting detail. ²Individual units cannot be joined. All end trims are factory installed and cannot be removed in the field. No through-wire provided. ³Continuous rows made up of both even and odd length fixtures. Designed to fall on-grid. Fixtures are through wired with quick connects. ⁴NF and NFN to be utilized for metal pan / millwork ceiling. ⁵347 and UNV not available with battery pack. ⁶Some Edge configurations will not accommodate all electrical options. Consult factory. ⁷Available for acoustical grid ceilings. Wall rail painted white unless otherwise specified. ⁸1/2" to 5/8" drywall thickness. Available for standard 1/2" flange (FL). ⁹Integral battery packs with remote test switch are provided with 1B option.



Pinnacle Architectural Lighting 12655 East 42nd Avenue, Suite 50 Denver, CO 80239
Phone 303.322.5570 Fax 303.322.5568 www.pinnacle-ltg.com
© 2012 Pinnacle Architectural Lighting® November 2013

Specifications and dimensions subject to change without notice. Specification sheets that appear on pinnacle-ltg.com are the most recent version and supersede all other previously printed or electronic versions

Submitted by LEESMAN LIGHTING



Job Name:
Miami U - Hahne Hall - LEE15-23278

Catalog Number:
E2R-1T5-4-GXG-120-1C-W

Type:
H2

Notes:

LEE15-23278

PHOTOMETRICS

EDGE 2R

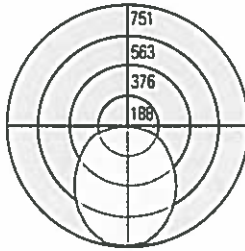

Test# 203079
Part #: E2R-1T5
Lamp: (1) 28W T5
Total Luminaire Efficiency: 69.4%

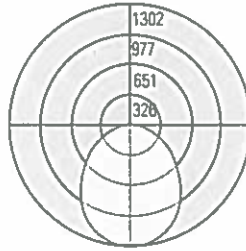

Test# 203080
Part #: E2R-1T5HO
Lamp: (1) 54W T5HO
Total Luminaire Efficiency: 69.8%

INDIVIDUAL AND CONTINUOUS RUN MODULES¹

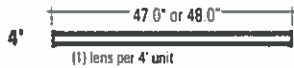
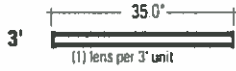
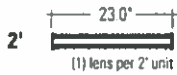

¹Available with acoustical grid ceiling and inaccessible ceilings. Individual units and rows are available for on-grid installation with acoustical ceilings.

MOUNTING DETAILS

1" Grid Mounting Options

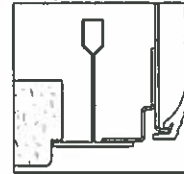
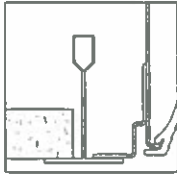

1" Grid, Standard Tile:
Specify **G1** or **G1G** in part #

1" Grid, Tegular Tile:
Specify **G1** or **G1G** in part #

9/16" Grid Mounting Options

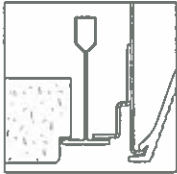
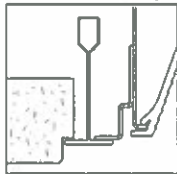
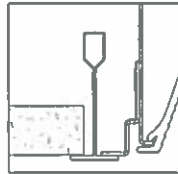

9/16" Grid, Standard Tile:
Specify **G9** or **G9G** in part #

9/16" Grid, Tegular Tile:
Specify **G9** or **G9G** in part #

9/16" Grid, Tegular Tile:
Specify **G9** or **G9G** in part #

Screw Slot Mounting

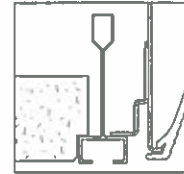

Screw Slot Grid:
Specify **G5** or **G5G** in part #

INACCESSIBLE CEILING MOUNTING

Flange Detail

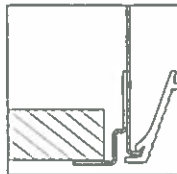

Exposed Flange Detail:
Specify **FL** or **FLF** in part #

Non-Flange

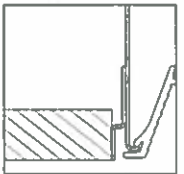

Metal Pan or Millwork:
Specify **NF** or **NFN** in part #

Spackle Flange

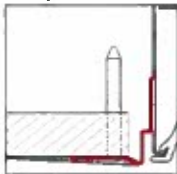

Drywall, Flangeless Look:
Specify **SF** or **SFS** in part #

SPECIALTY MOUNTS

Perimeter Mount

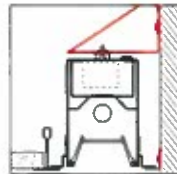

Bracket and Wall Rail:
Specify **PM** in part #

Rotating Crossbar

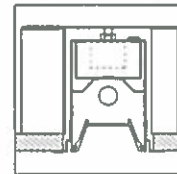

Unavailable Structure Support:
Specify **RC** in part #

NON-ILLUMINATED CONNECTOR

APPLICATION: Utilize non-illuminated connectors to create unique configurations. Recommended for gypsum board or inaccessible ceilings using the standard 1/2" flange mount (FL)

INSTALLATION: Non-illuminated connector easily joins to linear fixtures using standard Pinnacle Lighting joiner kits.

ORDERING INFORMATION: Specify Non-Illuminated Connector (CN) in the options section of the part number. Sample Catalog #: E2R-1T5-24-FL-120-1C-W-CN.

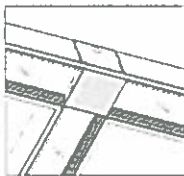

Pinnacle Architectural Lighting 12655 East 42nd Avenue, Suite 50 Denver, CO 80239
Phone 303.322.5570 Fax 303.322.5568 www.pinnacle-ltg.com
© 2012 Pinnacle Architectural Lighting® November 2013

Specifications and dimensions subject to change without notice. Specification sheets that appear on pinnacle-ltg.com are the most recent version and supersede all other previously printed or electronic versions.



EDGE_{WW}

LUMINOUS GEOMETRY™

1T5 Recessed Linear
Wall wash

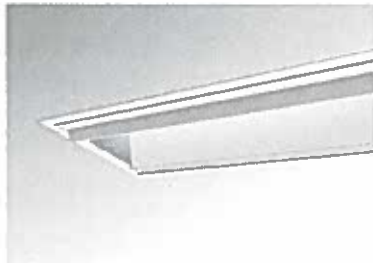

Project Name _____ Date _____
Catalog Number _____ Type _____

CONSTRUCTION Formed cold rolled steel housing. Ripple pattern extruded aluminum trim painted black for brightness control, highly specular extruded aluminum reflector (open) designed for perfect wall wash illumination.

ELECTRICAL Standard programmed start UL listed Class P, T5 electronic, Sound Rated A, thermally protected, high power factor ballasts less than 10% THD, Universal voltage (120/277) with 50/60Hz operation. Through wiring with quick connects standard on Continuous Runs. Standard single circuit. Integral battery packs with remote test switch are provided with 1B option. Each ballast provided with disconnects to meet luminaire disconnect code requirement.

MOUNTING Edge is designed to install into acoustical grid and inaccessible ceilings. Specify GXG, FL, SFS, NFN for individual, unjoinable units (individual units will fall on-grid). Specify GX, FL, SF, NF for continuous rows (Rows fall on-grid). Consult factory for detailed installation instructions.

APPLICATION GUIDELINE Edge Wall Wash recommended installation is 18" to 36" off the wall with optimal performance being at 24".

FINISH Standard powder-coat textured white painted finish on exposed trim, consult factory for custom colors.

LABELS UL and cUL Listed, approved for dry/damp location unless otherwise noted.

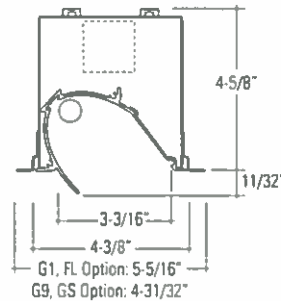

LUMINAIRE SPECIFICATION

Sample Catalog #: EW-1T5-24'-FL-120-1C-W

EW-	1T5						
HOUSING	LAMPS	LENGTH	MOUNTING ¹	VOLTAGE	CIRCUITING	FINISH	OPTIONS
EW Edge open wall wash	1T5 (1) T5 T15R0 (1) T5R0		INDIVIDUAL UNITS (CANNOT BE JOINED)² Acoustical Grid Ceiling G1G- 1" Ceiling Grid G9G- 9/16" Ceiling Grid GSG- Screw Slot Ceiling Grid Inaccessible Ceiling FLF- Standard 1/2" Flange SFS- Spackle Flange NFN- Flangeless ⁴ CONTINUOUS RUNS (JOINABLE)³ Acoustical Grid Ceiling G1- 1" Ceiling Grid G9- 9/16" Ceiling Grid GS- Screw Slot Ceiling Grid Inaccessible Ceiling FL- Standard 1/2" Flange SF- Spackle Flange NF- Flangeless ⁴	120- 120V 277- 277V 347- 347V ⁵ UNV- UNV ⁵ (120/277)	1C- Single Circuit 1D- Single Circuit Dimming ⁶ 1B- Single Circuit with Battery Pack ^{6,10} 1E- Single Circuit with Emergency Circuit ⁶	W- Matte White CC- Custom Color	QS- Quick Ship ⁷ RC- Rotating Crossbar ⁸ M- MR16 Lamp ⁹ CP- Chicago Plenum LC- Clear Acrylic Lens B- Baffle
	Individual Units² 2- 2', 23" unit 3- 3', 35" unit 4- 4', 47" unit 6- 6', 71" unit 8- 8', 95" unit Continuous Runs³ xx"- Specify nominal overall row length in 1' increments		CONFIRM GRID SIZE				

¹See back page for mounting detail. Consult factory for regular edged tiles. ²Individual units cannot be joined. All end trims are factory installed and cannot be removed in the field. No through-wire provided. ³Continuous rows made up of both even and odd length fixtures. Designed to fall on-grid. Fixtures are through wired with quick connects. ⁴NF and NFN to be utilized for metal pan / millwork ceiling. ⁵347 volt and UNV not available with MR16 and battery packs. ⁶Some Edge configurations will not accommodate all electrical options. Consult factory. ⁷Includes EW, 4 ft individual unjoinable units, G1G, FLF mounts, Universal voltage, std white finish, single and dual circuit. ⁸1/2" to 5/8" drywall thickness. Available for standard 1/2" flange (FL). ⁹See back page for information. ¹⁰Integral battery packs with remote test switch are provided with 1B and 2B options.



Pinnacle Architectural Lighting 12655 East 42nd Avenue, Suite 50 Denver, CO 80239
 Phone 303.322.5570 Fax 303.322.5568 www.pinnacle-ltg.com
 © 2014 Pinnacle Architectural Lighting® April 2014

Specifications and dimensions subject to change without notice. Specification sheets that appear on pinnacle-ltg.com are the most recent version and supersede all other previous printed or electronic versions.

Submitted by LEESMAN LIGHTING



Job Name:
Miami U - Hahne Hall - LEE15-23278

Catalog Number:
EW-1T5-4-GXG-120-1C-W

Notes:

Type:
H3

LEE15-23278

PHOTOMETRICS

EDGE WW



Test #202263
Part #: EW-1T5-4
Total Luminaire Efficiency 71.2%

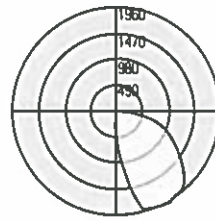

Test #202264
Part #: EW-1T5H0-4
Total Luminaire Efficiency 71.8%

INDIVIDUAL AND CONTINUOUS RUN MODULES¹

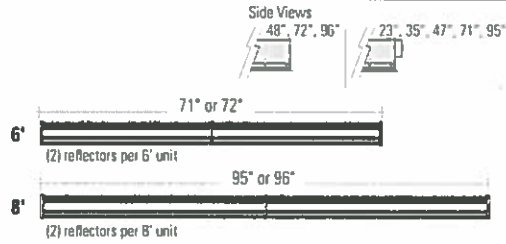
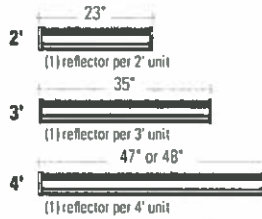

¹Acoustical Grid Ceiling and Inaccessible Ceilings available as individual units or continuous rows. Individual units and rows are available for on-grid installation with acoustical ceilings.

MOUNTING DETAILS

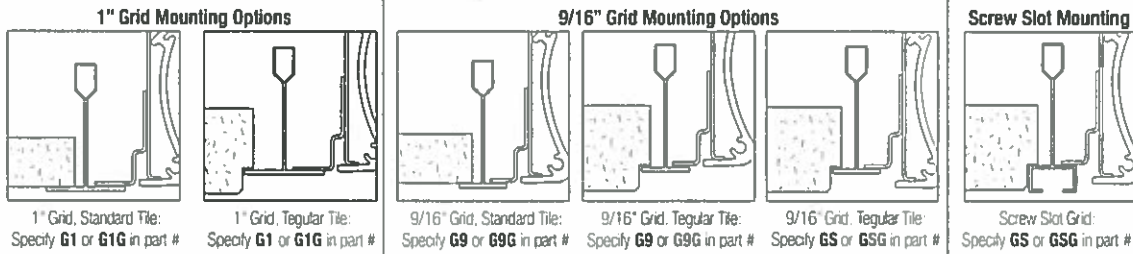

INACCESSIBLE CEILING MOUNTING

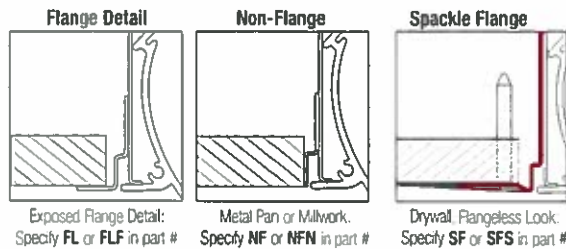

SPECIALTY MOUNTS

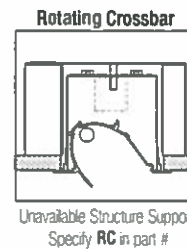

MR16 HALOGEN LAMP

APPLICATION: MR16's are ideal for conference rooms, corridors, wall washing, retail spaces and training facilities where accent lighting is required.

TECHNICAL: MR16 fully enclosed compartment eliminates light from entering into other fixture areas. Available in 20, 35 and 50 watt halogen lamps (lamps not included). Consult factory for other lamp types. Lamp tilts to 35 degrees left or right with 179 degree rotation.

ELECTRICAL: Standard 50 watt max halogen lamp transformer. MR16 installed as independent circuit. MR16 voltage to match fluorescent voltage. Universal voltage and 347 volt not available.

LABELS: UL and cUL Listed, approved for dry/damp location unless otherwise noted.

ORDERING INFORMATION: Specify MR16 layout and lens in the options section of the part number. Sample Catalog #: EW-1T5-2-FL-120-1C-S-M2/LP. See MR16 Resource Guide for Layout and Lens Options.



BAFFLE

APPLICATION: Baffle controls glare and provides lengthwise shielding of lamp.

CONSTRUCTION: Curved baffles are highly reflective white painted aluminum. Baffles are field installed and feature a snap-in attachment.

ORDERING INFORMATION: Specify Baffle (B) in the options section of the part number. Sample Catalog #: EW-1T5-24-FL-120-W-B.



CLEAR ACRYLIC LENS

APPLICATION: Lens is ideal for applications requiring lamp protection.

CONSTRUCTION: Clear acrylic lens lays in a allowing for easy lamp replacement.

ORDERING INFORMATION: Specify Clear Acrylic Lens (LC) in the options section of the part number. Sample Catalog #: EW-1T5-2-FL-120-1C-S-LC.



Pinnacle Architectural Lighting 12655 East 42nd Avenue, Suite 50 Denver, CO 80239
Phone 303 322 5570 Fax 303 322 5568 www.pinnacle-ltg.com
© 2014 Pinnacle Architectural Lighting® April 2014

Specifications and dimensions subject to change without notice. Specification sheets that appear on pinnacle-ltg.com are the most recent version and supersede all other previous printed or electronic versions.

Submitted by LEESMAN LIGHTING



Job Name:
Miami U - Hahne Hall - LEE15-23278

Catalog Number:
E4A-2T8-4-GXG-120-1C-W-RS

Type:

L

Notes:

LEE15-23278

EDGE 4A

LUMINOUS GEOMETRY™

T5, T5HO, T8 Recessed Linear with
Straight and Staggered Lamp / Satine Lens

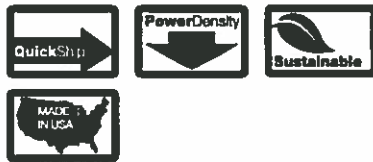
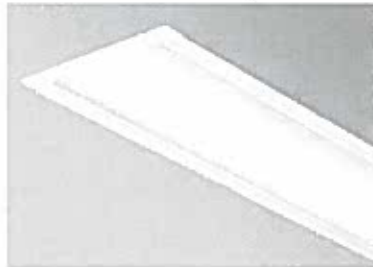

Project Name _____ Date _____

Catalog Number _____ Type _____

CONSTRUCTION Formed cold-rolled steel housing. Highly reflective die-formed white painted steel reflector, 125" diffuse snap-in acrylic lens with matte finish, removable for lamp replacement.

ELECTRICAL T5, T5HO: Standard programmed start UL listed Class P, T5 electronic, sound rated A, thermally protected, high power factor ballasts less than 10% THD, universal voltage (120/277) with 50/60Hz operation. T8: Standard instant start UL listed Class P, T8 electronic, Sound Rated A, thermally protected, high power factor ballasts less than 10% THD Universal voltage (120/277). Through wiring with quick connects standard on Continuous Runs. Standard single circuit. Integral battery packs with remote test switch are provided with 1B and 2B options. Each ballast provided with disconnects to meet luminaire disconnect code requirement.

MOUNTING Edge is designed to install into acoustical grid and inaccessible ceilings. Specify GXG, FLF, SFS, NFN for individual, unjoinable units (individual units will fall on-grid). Specify GX, FL, SF, NF for continuous runs (runs designed to fall on-grid). Consult factory for detailed installation instructions.

FINISH Standard powder-coat textured white painted finish on exposed trim, consult factory for custom colors

LABELS UL and cUL Listed, approved for dry/damp location unless otherwise noted.

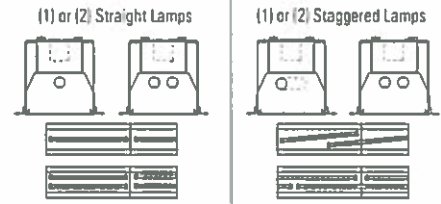
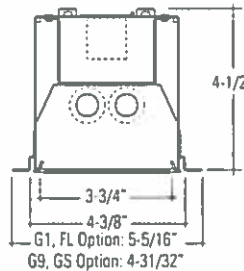

See Straight or Staggered Lamp Guide for row configuration, wattage and number of lamps per run.

LUMINAIRE SPECIFICATION

Sample Catalog #: E4A-1T5-24'-FL-120-1C-W

E4A-	T						
HOUSING	LAMPS	LENGTH	MOUNTING ¹	VOLTAGE	CIRCUITING	FINISH	OPTIONS
E4A- Edge 4 Acrylic Lens, Straight Lamp E4SA- Edge 4 Acrylic Lens, Staggered Lamps	1T5- (1) T5 1T5HO- (1) T5HO 2T5- (2) T5 2T5HO- (2) T5HO 1T8- (1) T8 2T8- (2) T8	Individual Units ² 2- 2', 23" fixture (Staggered not available) ¹ 3- 3', 35" fixture (Staggered not available) ¹ 4- 4', 47" fixture (Staggered not available) ¹ 6- 6', 71" fixture ³ 8- 8', 95" fixture ³ Continuous Runs ² xx ² - Specify nominal overall row length in 1' increments	INDIVIDUAL UNITS (CANNOT BE JOINED) ² Acoustical Grid Ceiling G1G- 1" Ceiling Grid G9G- 9/16" Ceiling Grid GSG- Screw Slot Ceiling Grid Inaccessible Ceiling FLF- Standard 1/2" Flange SFS- Spackle Flange NFN- Flangeless ³ CONTINUOUS RUNS (JOINABLE) ² Acoustical Grid Ceiling G1- 1" Ceiling Grid G9- 9/16" Ceiling Grid GS- Screw Slot Ceiling Grid Inaccessible Ceiling FL- Standard 1/2" Flange SF- Spackle Flange NF- Flangeless ³ CONFIRM GRID SIZE	120- 120 V 277- 277 V ⁴ 347- 347 V ⁴ UNV- UNV ⁵ (120/277)	1C- Single Circuit 2C- Dual Circuit ⁶ 1D- Single Circuit Dimming ⁶ 2D- Dual Circuit Dimming 1B- Single Circuit with Battery Pack ^{4,11} 2B- Dual Circuit with Battery Pack ^{4,11} 1E- Single Circuit with Emergency Circuit ⁶ 2E- Dual Circuit with Emergency Circuit ⁶	W- Matte White CC- Custom Color	QS- Quick Ship ⁷ PM- Perimeter Mount ⁸ CP- Chicago Plenum M- MR16 Lamp ⁹ RC- Rotating Crossbar ⁹ CN- Non-Illuminated Connector E4SCH- 90° Horizontal Corner (staggered lamp only) ¹² E4SCI- 90° Inside Corner (staggered lamp only) ¹² E4SCD- 90° Outside Corner (staggered lamp only) ¹² RAPID START BALLAST

¹See back page for mounting detail. ²Individual units cannot be joined. All end trims are factory installed and cannot be removed in the field. No through-wire provided. ³Continuous rows made up of both even and odd length fixtures. Designed to fall on-grid. Fixtures are through wired with quick connects. ⁴NF and NFN to be utilized for metal pan / millwork ceiling. ⁵347 and UNV not available with MR16 lamp and battery pack. ⁶Some Edge configurations will not accommodate all electrical options. Consult factory. ⁷Includes E4A, 4 ft individual, unjoinable units, G1G and FLF mounts, universal voltage, std white finish, 1C and 2C circuiting. ⁸Available for acoustical grid ceilings. Wall rail painted white unless otherwise specified. ⁹1/2" to 5/8" drywall thickness. Available for standard 1/2" flange (FL). ¹⁰See back page for MR16 information. ¹¹Integral battery packs with remote test switch are provided with 1B and 2B options. ¹²Corners are available with staggered lamp only. See Edge 4 corner specification sheets for ordering information.



Pinnacle Architectural Lighting 12655 East 42nd Avenue, Suite 50 Denver, CO 80239
Phone 303.322.5570 Fax 303.322.5568 www.pinnacle-ltg.com
© 2012 Pinnacle Architectural Lighting® November 2013

Specifications and dimensions subject to change without notice. Specification sheets that appear on pinnacle-ltg.com are the most recent version and supersede all other previously printed or electronic versions.

Submitted by LEESMAN LIGHTING



Job Name:
Miami U - Hahne Hall - LEE15-23278

Catalog Number:
E4A-2T8-4-GXG-120-1C-W-RS

Type:



LEE15-23278

Notes:

PHOTOMETRICS

EDGE 4A



Test# 203081
Part #: E4A-1T5-4'
Total Luminaire Efficiency: 74.6%

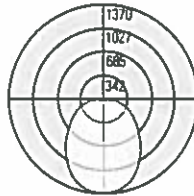

Test# 203084
Part #: E4A-2T5-4'
Total Luminaire Efficiency: 70.6%

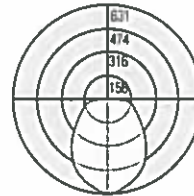

Test# 203083
Part #: E4A-1T8-4'
Total Luminaire Efficiency: 58%

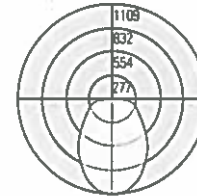

Test# 203086
Part #: E4A-2T8-4'
Total Luminaire Efficiency: 48.4%

• INDIVIDUAL AND CONTINUOUS RUN MODULES¹

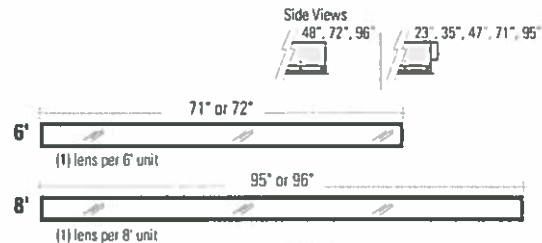
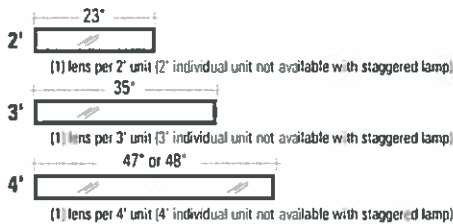

¹Acoustical Grid Ceiling and Inaccessible Ceilings available as individual units or continuous rows. Individual units and rows are available for on-grid installation with acoustical ceilings.

• MOUNTING DETAILS

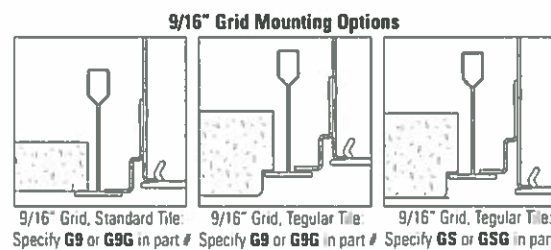
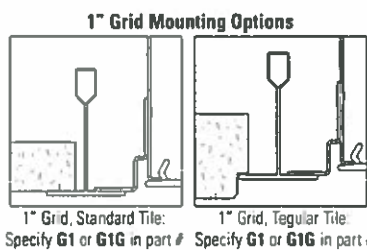

• INACCESSIBLE CEILING MOUNTING

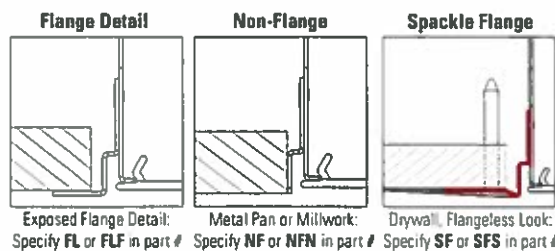

• SPECIALTY MOUNTS

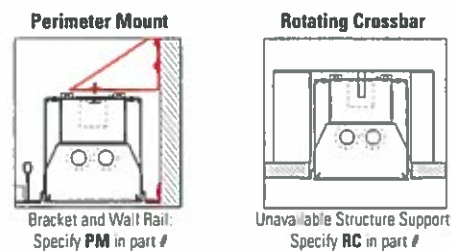

• MR16 HALOGEN LAMP

APPLICATION: MR16's are ideal for conference rooms, corridors, wall washing, retail spaces and training facilities where accent lighting is required.

TECHNICAL: MR16 fully enclosed compartment eliminates light from entering into other fixture areas. Available in 20, 35 and 50 watt halogen lamps (lamps not included). Consult factory for other lamp types. Lamp tilts to 35 degrees left or right with 179 degree rotation.

ELECTRICAL: Standard 50 watt max halogen lamp transformer. MR16 installed as independent circuit. MR16 voltage to match fluorescent voltage. Universal voltage and 347 volt not available.

LABELS: UL and cUL Listed, approved for dry/damp location unless otherwise noted.

ORDERING INFORMATION: Specify MR16 layout and lens in the options section of the part number. Sample Catalog #: E4A-1T5-2-FL-120-1C-S-M2/LP. See MR16 Resource Guide for Layout and Lens Options.



• CORNER AND NON-ILLUMINATED CONNECTOR

APPLICATION: Utilize corners and non-illuminated connectors to create unique configurations.

INSTALLATION: Corners and connector easily joins to linear fixtures using standard Pinnacle Lighting joiner kits.

ORDERING INFORMATION: Specify Non-Illuminated Connector (CN) in the options section of the part number. Sample Catalog #: E4A-1T5-24-FL-120-1C-W-CN. Specify Corners using Edge Corner specification sheets.

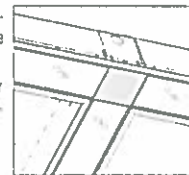

Pinnacle Architectural Lighting 12655 East 42nd Avenue, Suite 50 Denver, CO 80239
Phone 303.322.5570 Fax 303.322.5568 www.pinnacle-ltg.com
© 2012 Pinnacle Architectural Lighting® November 2011

Specifications and dimensions subject to change without notice. Specification sheets that appear on pinnacle-ltg.com are the most recent version and supersede all other previously printed or electronic versions.

VAPOR™ OUTDOOR SCENCE

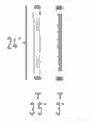

FIGURE WEIGHT 4 LBS



FIGURE WEIGHT 5 LBS



FIGURE WEIGHT 6 LBS

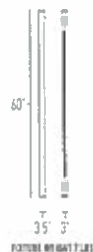

FIGURE WEIGHT 7 LBS



VP1-010A-24-GW-SGP



VP1-010A-24-GW-SGP



▼ MATCHING FIXTURES



page 262



page 456

▼ FEATURES

- The Vapor features an extruded aluminum back channel 2.50" wide and 0.725" thick with a matte anodized protective coating.
- Features solid aluminum die-cast ends with die-cut silicone foam gaskets.
- 0.08" thick aluminum decorative bar with silk cutout.
- 3/16" thick extruded virgin white acrylic is 45% OR high impact, UV stable, F1 rated, and UL-94 HB Flame Class rated.
- Extruded neoprene rubber gasket runs the length of the diffuser on both sides.
- Vapor can be mounted vertically or horizontally.
- 21 standard powder coat paints offered, however all RAL colors available.
- Utilizes highly efficient, long lasting and low mercury T5 or T5HO lamps for minimal fixture maintenance and lamp disposal.
- Contact factory for additional modifications or options.

FOR ADDITIONAL INFORMATION GO TO WWW.OCL.COM AND SEARCH: VAPOR OUTDOOR SCENCE

SERIES	HANGING SYSTEM	SIZE	DIFFUSER	FINISH	LAMPING PHOTOMETRIC TEST #	VOLTAGE	OPTIONS
VP1	O10A OUTDOOR ADA COMPLIANT SCENCE	24	GW GLOSS WHITE ACRYLIC	PTD PAINTED - SPECIFY CODE (EX. BKP FOR BLACK PAINT. SEE PAGE 492 FOR PAINT OPTIONS)	24" ADA 1LF14 1014W T5	120	DWA ADVANCE® DIMMING BALLAST
		36	SGP STEEL GRAY PAINTED FINISH	1LF24 1024W T5HO (15767.0)	277	DML LUTRON® DIMMING BALLAST	
		48		36" ADA 1LF21 1021W T5	347	EMR REMOTE MOUNT EMERGENCY (24/36" SIZES ONLY)	
		60		48" ADA 1LF39 1039W T5HO (15768.0)	EMR INTEGRAL EMERGENCY (48/60" SIZES ONLY)		
				60" ADA 1LF28 1028W T5	FUS FUSED		
				1LF54 1054W T5HO (15769.0)	SJB MOUNTING COVER FOR STANDARD 4" J-BOX (SEE BELOW)		
				1LF36 1036W T5	TPS TAMPER PROOF SCREWS		
				1LF80 1080W T5HO (15770.0)			

OUTDOOR

SPECIFY CATALOG CODE

VP1 - O10A - 24 - GW - SGP - 1LF24 - 120 - SJB

SAMPLE CODE: VP1-O10A-24-GW-SGP-1LF16-120-EMR

PHOTOMETRIC INFORMATION
AVAILABLE AT WWW.OCL.COM

- Fixture mounts to a standard 2" x 4" switch box (supplied by others), and requires additional anchors. See options section for standard 4" J-box mounting.
- Bodine® emergency ballast available, standard with remote mounted test switch and indicator light.
- Advance® and Lutron® dimming ballasts available. Controls not included.
- Integral HPF electronic fluorescent ballast with Class A sound rating, 0°F/-18°C starting temperature (3-5 year ballast warranty depending on ballast specification).
- Fixture is ADA compliant.
- Tamper-proof stainless steel screws available as an option.
- For photometric data, please visit www.ocl.com.
- For lamp and base information, see pages 496-505 in the reference section.
- For specific mounting instructions, please contact factory.
- Five year product warranty.



SJB
MOUNTING COVER FOR
STANDARD 4" J-BOX

VAPOR™ OUTDOOR SCENCE

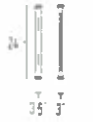

FIGURE WEIGHT & LBS



FIGURE WEIGHT & LBS



FIGURE WEIGHT & LBS

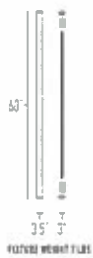

FIGURE WEIGHT & LBS



VP1-010A-24-GW-SGP



VP1-010A-24-GW-SGP



MATCHING FIXTURES



page 242





page 456

FEATURES

- The Vapor features an extruded aluminum back channel 2.50" wide and 0.125" thick with a matte anodized protective coating.
- Features solid aluminum die-cast ends with die-cut silicone foam gaskets.
- 0.00" thick aluminum decorative bar with slit cutout.
- 3/16" thick extruded virgin white acrylic is 45% DR high impact, UV stable, F1 rated, and UL-94 HB Flame Class rated.
- Extruded neoprene rubber gasket runs the length of the diffuser on both sides.
- Vapor can be mounted vertically or horizontally.
- 21 standard powder coat paints offered, however all RAL colors available.
- Utilizes highly efficient, long lasting and low mercury T5 or T5HO lamps for minimal fixture maintenance and lamp disposal.
- Contact factory for additional modifications or options.

FOR ADDITIONAL INFORMATION GO TO WWW.OCL.COM AND SEARCH: VAPOR OUTDOOR SCONCE

SERIES	HANGING SYSTEM	SIZE	DIFFUSER	FINISH	LAMPING (PHOTOMETRIC TEST #)	VOLTAGE	OPTIONS
 VP1	 O10A OUTDOOR ADA COMPLIANT SCONCE	24	GW GLOSS WHITE ACRYLIC	PTD PAINTED - SPECIFY CODE (EX. BWP FOR BLACK PAINT. SEE PAGE 492 FOR PAINT OPTIONS) SGP STEEL GRAY PAINTED FINISH	24" ADA 1LF14 10-14W T5 1LF24 10-24W T5HO [10097]	120	DMA ADVANCE® DIMMING BALLAST
		36	36" ADA 1LF21 10-21W T5 1LF39 10-39W T5HO [10097]		277	DML LUTRON® DIMMING BALLAST	
		48	48" ADA 1LF28 10-28W T5 1LF34 10-34W T5HO [10097]		347	EMR REMOTE MOUNT EMERGENCY (24/36 SIZES ONLY)	
		60	48" ADA 1LF35 10-35W T5 1LF80 10-80W T5HO [10097]			EMR INTEGRAL EMERGENCY (48/60 SIZES ONLY)	
							FUS FUSED
							SJB MOUNTING COVER FOR STANDARD 4" J-BOX (SEE BELOW)
							TPS TAMPER PROOF SCREWS

OUTDOOR

☑ SPECIFY CATALOG CODE

VP1 - O10A - 36 - GW - SGP - 1LF39 - 120 - SJB

SAMPLE CODE: VP1-O10A-24-GW-SGP-1LF14-120-EMR

↑ PHOTOMETRIC INFORMATION
 AVAILABLE AT WWW.OCL.COM

- Fixture mounts to a standard 2" x 4" switch box (supplied by others, and requires additional anchors. See options section for standard 4" J-box mounting).
- Base line® emergency ballast available, standard with remote mounted test switch and indicator light.
- Advance® and Lutron® dimming ballasts available. Controls not included.
- Integral HFF electronic fluorescent ballast with Class A sound rating, 0°F/-18°C starting temperature (3-5 year ballast warranty depending on ballast specification).
- Fixture is ADA compliant.
- Tamper-proof stainless steel screws available as an option.
- For photometric data, please visit www.ocl.com.
- For lamp and base information, see pages 496-505 in the reference section.
- For specific mounting instructions, please contact factory.
- Five year product warranty.



SJB
 MOUNTING COVER FOR
 STANDARD 4" J-BOX

VAPOR™ OUTDOOR SCNCE

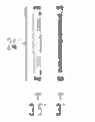

FIXTURE WEIGHT 4 LBS

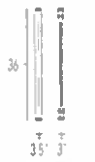

FIXTURE WEIGHT 6 LBS

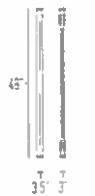

FIXTURE WEIGHT 8 LBS

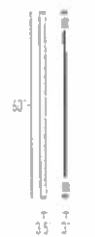

FIXTURE WEIGHT 7 LBS



VP1-010A-24-GW-5GP



VP1-010A-24-GW-SGP



MATCHING FIXTURES



page 262



page 456

FEATURES

- The Vapor features an extruded aluminum back channel 2.50" wide and 0.125" thick with a matte anodized protective coating.
- Features solid aluminum die-cast ends with die-cut silicone foam gaskets.
- 0.08" thick aluminum decorative bar with slit cutout.
- 3/16" thick extruded virgin white acrylic is 45% DR high impact, UV stable, F1 rated, and UL-94 HB Flame Class rated.
- Extruded neoprene rubber gasket runs the length of the diffuser on both sides.
- Vapor can be mounted vertically or horizontally.
- 21 standard powder coat paints offered, however all RAL colors available.
- Utilizes highly efficient, long lasting and low mercury T5 or T5HO lamps for minimal fixture maintenance and lamp disposal.
- Contact factory for additional modifications or options.





Project 15-20238-4
 MIAMI UNIVERSITY HAHNE HALL
 Submitted By
 KING LIGHTING INC

Catalog Number
 VP1 -O10A -48 -GW -PTD -1LF54 -120 -SJB
 Notes

Type

N4

FOR ADDITIONAL INFORMATION GO TO WWW.OCL.COM AND SEARCH: YAPOR OUTDOOR SCONCE

SERIES	HANGING SYSTEM	SIZE	DIFFUSER	FINISH	LAMPING (PHOTOMETRIC TEST #)	VOLTAGE	OPTIONS
 VP1	 O10A OUTDOOR ACA COMPLIANT SCONCE	24	GW GLOSS WHITE ACRYLIC	PTD PAINTED - SPECIFY CODE (EX. BWP FOR BLACK PAINT. SEE PAGE 492 FOR PAINT OPTIONS)	24" ADA	120	DMA ADVANCE® DIMMING BALLAST
					1LF14 1014W T5	277	DML LUTRON® DIMMING BALLAST
					1LF24 1024W T5HO (137492)	347	EMR REMOTE MOUNT EMERGENCY (24/736 SIZES ONLY)
					36" ADA	EMI INTEGRAL EMERGENCY (48/760 SIZES ONLY)	
					1LF21 1021W T5	FUS FUSED	
					1LF39 1039W T5HO (137492)	SJB MOUNTING COVER FOR STANDARD 4" J-BOX (SEE BELOW)	
					48" ADA	TPS TAMPER PROOF SCREWS	
					1LF28 1028W T5		
					1LF54 1054W T5HO (137492)		
					48" ADA		
	1LF35 1035W T5						
	1LF80 1080W T5HO (137492)						

OUTDOOR

SPECIFY CATALOG CODE

VP1 - O10A - 48 - GW - PTD - 1LF54 - 120 - SJB

SAMPLE CODE: VP1-O10A-24-GW-SGP-1LF14-120-EMR

PHOTOMETRIC INFORMATION
 AVAILABLE AT WWW.OCL.COM

- Fixture mounts to a standard 2" x 4" switch box (supplied by others), and requires additional anchors. See options section for standard 4" J-box mounting.
- Bodine® emergency ballast available, standard with remote mounted test switch and indicator light.
- Advance® and Lutron® dimming ballasts available. Controls not included.
- Integral HPF electronic fluorescent ballast with Class A sound rating 07F/-18°C starting temperature 13-5 year ballast warranty depending on ballast specification).
- Fixture is ADA compliant.
- Tamper-proof stainless steel screws available as an option.
- For photometric data, please visit www.ocl.com.
- For lamp and base information, see pages 476-505 in the reference section.
- For specific mounting instructions, please contact factory.
- Five year product warranty.



SJB
 MOUNTING COVER FOR
 STANDARD 4" J-BOX



Job Name:

Contact:

Ordering Code: 137-206-CH-4-MP-XX

Fixture Type: S

Titan M

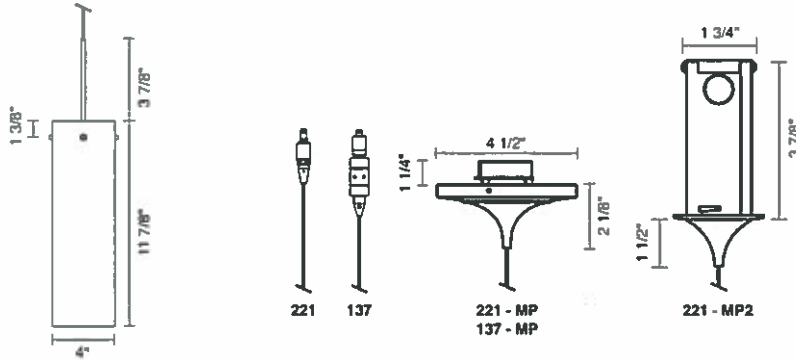

Description

The Titan M is a compliment to any palette or design. The standard series features classic plated chrome or anodized Bronze and Matte Chrome. Allow your imagination to take over with a wide variety of colors and finishes, featured with the Designer Series, to complete your space and scheme with a classic cylindrical shape. The Designer series finishes of anodized gloss never looked so good. Match a company logo or design with your school colors. The possibilities are endless with this versatile piece.

Titan M is offered as part of our best selling Chroma series offering perfect white light with a SDCM of only 2 through the use of a single source remote phosphor LED module by Xicato® carrying its signature 5 year NO COLOR SHIFT warranty. It is also offered with a standard MR16 lamping option up to 50w for a warm glow at the surface.

LED Performance

- LED: Patented Cold Remote Phosphor, XICATO®
- DUV: 1 x 2 MacAdam Ellipse, +/- 50 Kelvin
- CCT: 2700k, 3000k, or 4000k
- CRI: >80 - typically 82
- LIFE: 85% at 50k hrs based on LM-80 testing
5 year "no color shift" warranty



LM-79

Ordering Codes

Follow the steps to specify your fixture,

example: 137 - 206 - bz - MP - GLD

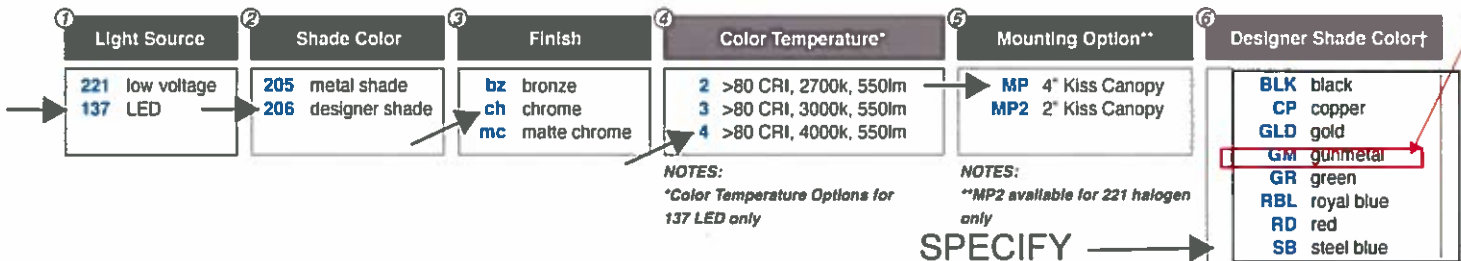

NOTES:
*Color Temperature Options for 137 LED only

NOTES:
**MP2 available for 221 halogen only

SPECIFY COLOR

NOTES:
†Designer Shade color and finish for 206 only



Job Name: _____

Contact: _____

Ordering Code: _____

Fixture Type: _____



BLK black

CP copper

GLD gold

GM gunmetal



GR green

RBL royal blue

RD red

SB steel blue

low voltage
uni-plug

221 - xxx

- 12V AC/DC input
- 50W, 50VA (max 50 Watt lamp)
- GU5.3 socket
- Dimmable
- Suitable for dry locations only
- Connects to UNI-LIGHT system with appropriate low voltage adapter (V/A, Enzis, High-Line) or line voltage adapter (Eco, Geo, Zonyx)

LED
uni-plug

137 - xxx

- 12V AC/DC, 50/60 Hz input
- 9 6W, 12 4VA
- Dimmable by power supply, magnetic low voltage
- Not compatible with electronic transformers
- Suitable for dry locations only
- Compatible with selected Bruck electronic transformers and must meet the minimum VA (load)
- Connects to UNI-LIGHT system with appropriate low voltage adapter (V/A, Enzis, High-Line)

low voltage
4" Kiss Canopy

221 - xxx - MP

- 120VAC, 50/60Hz input
- 11 7V AC output 49W, 50VA (max 50 Watt lamp)
- GU5.3 socket
- Dimmable (Trailing Edge ELV)
- Suitable for dry locations only
- Mount to 3 1/2" - 4" round J-Box
- Short circuit protection
- Overload protection
- Thermal protection

LED
4" Kiss Canopy

137 - xxx - MP

- 100-277VAC, 50/60Hz input
- 9W, 16VA for 1 (3 x 3 Watt LED)
- Suitable for dry locations only
- Mount to 3 1/2" - 4" round J-Box
- Short circuit protection
- Thermal protection

low voltage
2" Kiss Canopy

221 - xxx - MP2

- 120VAC, 50/60Hz input
- 11 7V AC output 49W, 50VA (max 50 Watt lamp)
- GU5.3 socket
- Dimmable (Trailing Edge ELV)
- Suitable for dry locations only
- 2 1/4" hole cutout
- Required material thickness 3/16" - 1 1/16"
- Not thru-wire rated
- Short circuit protection
- Overload protection
- Thermal protection

SOLID FRONT UNDER CABINET LIGHT

CATALOG #	TYPE:
PROJECT:	NOTES:

EXAMPLE **1SF** - **4** - **L24/835** - **AF12125** - **OPTIONS** - **DRV** - **UNV**

 SERIES NOMINAL LENGTH LUMEN PACKAGE CRI & CCT SHIELDING OPTIONS DRIVER VOLTAGE

1SF

LED





FEATURES

- ▶ Small profile allows inconspicuous placement in confined spaces
- ▶ Provides uniform, glare-free task lighting.
- ▶ Housing keyhole slots and knockouts provide quick and easy installation.
- ▶ Individual or continuous row mounting
- ▶ All-welded construction provides long lasting performance
- ▶ Optional anti-microbial white finish available for use in healthcare applications
- ▶ LED technology provides high efficacy and energy efficiency
- ▶ Rated for 50,000 hours at 85% lumen maintenance (L85)
- ▶ Minimum 82 CRI, 3000K, 3500K, or 4000K CCT.
- ▶ This fixture is proudly made in the USA.

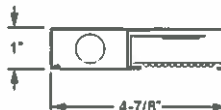

SPECIFICATIONS

Housing – 20-gauge die-formed, welded C R S

Shielding – Frosted acrylic, pattern #12, .125" thick.

Finish – 92% minimum average reflective white polyester powder coat bonded to phosphate-free, multi-stage pretreated metal. All parts painted after fabrication to facilitate installation, increase efficiency, and inhibit corrosion.

Electrical – High quality mid-power LED board(s) L85 at 50,000 hours. 25°C maximum ambient operating temperature.

Mounting – Surface

Labels – cCSAus certified as luminaire suitable for dry or damp locations.

Warranty – 5-year limited warranty, see hewilliams.com/warranty

ORDERING INFORMATION

SERIES

1SF Solid Front Under Cabinet Light

SHIELDING

AF12125 Frosted acrylic, pattern #12, .125" thick

NOMINAL LENGTH

2 2'
3 3'
4 4'

OPTIONS

Not available with EM option
GCO Grounded convenience outlet (120V only)
C&P/120 6-1/2' cord and plug, NEMA 5-15P (120V only)
WRS/120 White rocker switch (120V only)
AMW Anti-microbial white finish

LED PACKAGE

EXAMPLE: L24/840			AVERAGE SYSTEM WATTAGE
LUMEN PACKAGE	NOMINAL LUMENS	MINIMUM CRI & CCT	
2' UNIT			14
L12/	1,200	830 = 82 CRI, 3000K	
3' UNIT			21
L18/	1,800	835 = 82 CRI, 3500K 840 = 82 CRI, 4000K	
4' UNIT			29
L24/	2,400		

DRIVER

DRV Driver prewired for non-dimming applications

VOLTAGE

120 120V
277 277V
UNV 120-277V

SOLID FRONT UNDER CABINET LIGHT

CATALOG #	TYPE:
PROJECT:	NOTES:

EXAMPLE → 1SF - 4 - L24/835 - AF12125 - OPTIONS - DRV - UNV

↓ SERIES
↓ NOMINAL LENGTH
↓ LUMEN PACKAGE
↓ CRI & CCT
↓ SHIELDING
↓ OPTIONS
↓ DRIVER
↓ VOLTAGE

1SF

LED

FEATURES

- ▶ Small profile allows inconspicuous placement in confined spaces
- ▶ Provides uniform, glare-free task lighting.
- ▶ Housing keyhole slots and knockouts provide quick and easy installation.
- ▶ Individual or continuous row mounting.
- ▶ All-welded construction provides long lasting performance
- ▶ Optional anti-microbial white finish available for use in healthcare applications.
- ▶ LED technology provides high efficacy and energy efficiency.
- ▶ Rated for 50,000 hours at 85% lumen maintenance (L85).
- ▶ Minimum 82 CRI; 3000K, 3500K, or 4000K CCT.
- ▶ This fixture is proudly made in the USA.



SPECIFICATIONS

Housing – 20-gauge die-formed, welded C.R.S.

Shielding – Frosted acrylic, pattern #12, .125" thick

Finish – 92% minimum average reflective white polyester powder coat bonded to phosphate-free, multi-stage pretreated metal. All parts painted after fabrication to facilitate installation, increase efficiency, and inhibit corrosion.

Electrical – High quality mid-power LED board(s) L85 at 50,000 hours. 25°C maximum ambient operating temperature.

Mounting – Surface

Labels – cSAs certified as luminaire suitable for dry or damp locations

Warranty – 5-year limited warranty, see hewilliams.com/warranty

ORDERING INFORMATION

SERIES

1SF Solid Front Under Cabinet Light

SHIELDING

AF12125 Frosted acrylic, pattern #12, .125" thick

NOMINAL LENGTH

2	2'
3	3'
4	4'

OPTIONS

Not available with EM option

GCO Grounded convenience outlet (120V only)

C&P/120 6-1/2' cord and plug, NEMA 5-15P (120V only)

WRS/120 White rocker switch (120V only)

AMW Anti-microbial white finish

LED PACKAGE

EXAMPLE: L24/840			AVERAGE SYSTEM WATTAGE
LUMEN PACKAGE	NOMINAL LUMENS	MINIMUM CRI & CCT	
2' UNIT			
L12/	1,200	830 = 82 CRI, 3000K 835 = 82 CRI, 3500K 840 = 82 CRI, 4000K	14
L18/	1,800		21
4' UNIT			
L24/	2,400		29

DRIVER

DRV Driver prewired for non-dimming applications

VOLTAGE

120 120V

277 277V

UNV 120-277V

Providence® MicroCore™ – Medium Housing PROV

TYPE

FEATURES

- DLC Qualified
- Reliable, uniform, glare free illumination
- Types II, III, IV, V and custom distributions
- 3000K, 4200K, 5100K CCT
- 0-10V dimming ready
- Integral surge suppression
- LifeShield™ thermal protection
- 13 standard powder coat finishes

SPECIFICATIONS

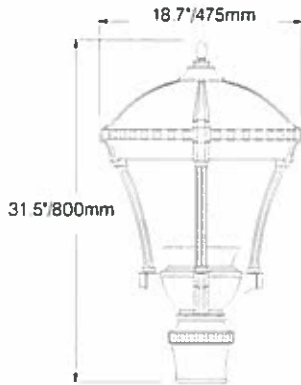

- Diameter: 18 7/8" / 475 mm
- Height: 31.5" / 800 mm
- Weight: 29 lbs
- EPA: 0.96
- IP Rating: 65



ORDERING INFORMATION

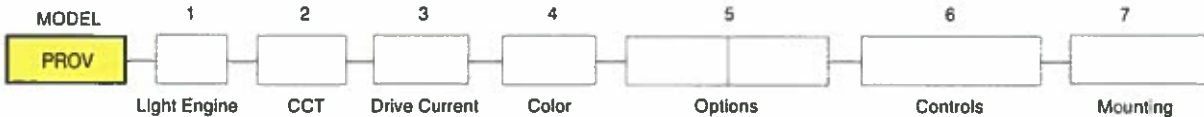

1. LIGHT ENGINE

MicroCore Precision aimed optics

- T2-32LED
- T3-32LED
- T4-32LED
- T5-32LED
- TL-32LED
- TR-32LED

2. COLOR TEMPERATURE

- 3K
- 4K
- 5K

3. DRIVE CURRENT

- 700
- 450

4. COLOR

- AWT
- BLK
- MTB
- DGN
- DBZ
- WRZ
- BRM
- VBL
- CRT
- MAL
- MDG
- ATG
- LGY
- RAL/PREMIUM COLOR
- CUSTOM COLOR

5. OPTIONS

- SPK (Decorative spike)
- BPS (Struts painted brass)
- LDL (Lightly diffused lens)
- CLR (Clear flat lens)
- HSS (House side shield)
- PFN (Finiel painted brass)
- EPA-C (Egress-Contemporary)
- EPA-T (Egress-Traditional)

6. CONTROL

- WIH (Integral HBA w iHUBB IFM transceiver and antenna)
- SCP (Programmable motion control, factory default is 50%, requires pole)
- PCA-C (Rotatable photocell-Contemporary)
- PCA-T (Rotatable photocell-Traditional)

7. MOUNTING

Standard configuration slips over a 4" DIA open top pole or may choose one.

Wall Mount Arm

- WMA7
- WMA55
- WMA56
- WMA57
- WMA9U
- WMA22U

Pole Mount Arm

- TRASU-4
- TRA6U-4
- TRA55
- TRA55-5
- TRA56
- TRA57-4
- TRA57-5
- SLA1
- SLA1-2
- SLA8U-4
- SLA8U-5
- SLA22U-4
- SLA22U-5

Pier Mount

- PM1
- PM2
- PM3

Option

- AD5



ARCHITECTURAL AREA LIGHTING
16555 East Gale Ave | City of Industry | CA 91745
P 626 968 5666 | F 626 369 2695 | www.aal.net
Copyright © 2014 Rev 2.15

JOB
TYPE
NOTES

Submitted by LEESMAN LIGHTING



Job Name:
Miami U - Hahne Hall - LEE15-23278

Catalog Number:
PROV-T2-32LED-3K-450-BLK-HSS-WMA56
Notes:

Type:

W1

LEE15-23278

Providence® MicroCore™ – Medium Housing PROV

TYPE

LUMINAIRE PERFORMANCE

Optical System	Secondary Lens or Shield	Distribution	Light Engine	Ordering Code												Drive Current	System Watts				
				3K				4K				5K									
				Delivered Lumens	Efficacy (Lm/W)	BUG Rating		Delivered Lumens	Efficacy (Lm/W)	BUG Rating		Delivered Lumens	Efficacy (Lm/W)	BUG Rating							
MicroCore	No Lens (Standard)	TYPE 2	T2-32LED	3796	51	1	0	2	5013	67	2	0	2	5449	73	2	0	3	700	75	
		TYPE 3	T3-32LED	3925	52	1	0	2	5183	69	1	0	3	5633	75	1	0	3			
		TYPE 4	T4-32LED	3740	50	0	0	1	4953	66	1	0	2	5375	72	1	0	2			
		TYPE 5	T5-32LED	3814	51	3	0	2	5058	67	3	0	2	5497	73	3	0	2			
		45° Left	TL-32LED	3887	52	1	0	1	4649	62	1	0	2	5115	68	1	0	2			
		45° Right	TR-32LED	3887	52	1	0	1	4649	62	1	0	2	5115	68	1	0	2			
	HSS	No Lens (Standard)	TYPE 4	T4-32LED	2726	36	0	0	2	3663	49	0	0	2	3911	52	0	0	2	450	48
			TYPE 2	T2-32LED	2429	51	1	0	2	3208	67	1	0	2	3497	73	1	0	2		
		TYPE 3	T3-32LED	2512	52	1	0	2	3317	69	1	0	2	3605	75	1	0	2			
		TYPE 4	T4-32LED	2394	50	0	0	1	3170	66	0	0	1	3440	72	0	0	1			
		TYPE 5	T5-32LED	2441	51	2	0	1	3237	67	2	0	2	3518	73	2	0	2			
		45° Left	TL-32LED	2488	52	0	0	1	2976	62	1	0	1	3273	68	1	0	1			
		45° Right	TR-32LED	2488	52	0	0	1	2976	62	1	0	1	3273	68	1	0	1			
		HSS	TYPE 4	T4-32LED	1745	36	0	0	1	2344	49	0	0	1	2503	52	0	0	2		

* DesignLights Consortium® Qualified Product



ELECTRICAL CHARACTERISTICS

Optical System	Ordering Code	LED Drive mA	System Watts	Driver						Dimming								
				Line Voltage		Amps AC		Min. Power Factor	Max THD (%)	Operating Temp. Range	Dimming Range	Source current out of 0-10V purple wire			Absolute voltage range on 0-10V (+) purple wire			
				VAC	HZ	120	277					Min	Typical	Max	Min	Typical	Max	
MicroCore	32LED	700	700	75	120-277	50/60	0.6	0.3	≥ 9	20	-30°C TO +40°C	10% TO 100%	0 MA	-	2 MA	-2.0 V	-	+15 V
		450	450	48			0.4	0.2										

LED COLOR

Consult factory for Amber, Turtle Friendly, Gulf Coast and Observatory applications.

	Ordering Code		
	3K	4K	5K
CCT Average	3000K	4200K	5100K
CCT Range	2800K – 3175K	3800K – 4600K	4600K – 5600K
CRI Minimum	≥ 80	≥ 70	≥ 70

WIRING LEADS

Luminaires not configured with wiHUBB or photo-control shall be provided with 0-10 purple and gray dimming leads

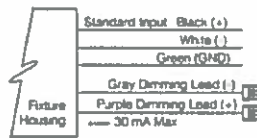

TM-21 LIFETIME CALCULATION

Optical System	Ordering Code	Ambient Environment °C	Projected Lumen Maintenance (% vs. Khrs)					Reported L70
			15	25	50	TM-21* 60	100	
MicroCore	32LED	15	93	91	87	84	78	>60Khrs
		25	93	91	87	85	78	
		40	93	91	87	85	78	



ARCHITECTURAL AREA LIGHTING
16555 East Gale Ave | City of Industry | CA 91745
P 626 968 5666 | F 626 369 2695 | www.aal.net
Copyright © 2014 Rev 2.15

JOB
TYPE
NOTES



Job Name:
Miami U - Hahne Hall - LEE15-23278

Catalog Number:
PROV-T2-32LED-3K-450-BLK-HSS-
WMA56

Notes:

Type:

W1

LEE15-23278

Providence® MicroCore™ – Medium Housing PROV

TYPE

SPECIFICATIONS

HOUSING

- Luminaire shall have discrete optical and gear compartments that do not share any physical housings.
- All housing components shall be die-cast aluminum, sealed with continuous silicone rubber gaskets.
- Standard configurations do not require a flat lens, optional lenses shall be tempered glass.
- All internal and external hardware shall be stainless steel.
- Optical bezel finish shall match the luminaire housing.

OPTICAL

- Patent pending MicroCore™ LED modules shall independently aim each light emitting diode (LED) in both horizontal rotation and vertical tilt angle.
- LEDs shall be mounted to a metal printed circuit board assembly (PCBA) with a uniform conformal coating over the panel surface and electrical features.
- LED optics shall be clear injection molded PMMA acrylic.
- MicroCore™ PCBA and optic shall be sealed to a die-cast anodized aluminum heat sink with an injection molded silicone rubber gasket. IP66.
- Type 4 distribution with optional House Side Shield not available with clear or diffused glass lenses. Factory installed House Side Shield is optimized for Type 4 distribution and not recommended for use with Type 2 or 3 distribution and not available with type 5 distribution.

ELECTRICAL

- Luminaires shall have integral surge protection that shall be U.L. recognized and have a surge current rating of 10,000 Amps using the industry standard 8/20uSec wave and surge rating of 372J.
- Drivers shall be U.L. recognized with an inrush current maximum of <20.0 Amps maximum at 230VAC.
- Drivers shall not be compatible with current sourcing dimmers, consult factory for current list of known compatible dimming systems, approved dimmers include Lutron Diva AVTV, Lutron Nova NFTV and NTFTV.
- LifeShield™ shall be provided with all configurations for added protection in the event of abnormally excessive high ambient temperature conditions.

CONTROLS

- wiHUBB® In-fixture Module shall operate at 900 MHz in a self-healing mesh network, luminaires configured with wiHUBB® shall be required to be commissioned on site with a wiHUBB® access point.

PHOTOCELL / EGRESS ADAPTERS

- Adapter(s) shall slip over a 4 7/100mm DIA. pole with the luminaire or arm slipping over the adapter to add a total of 4 5 7/114mm to the overall height. Adapter(s) shall be prewired, independently rotatable 359°, and have a cast access cover with an integral lens and lanyard.
- Photocell adapter shall include an internal twist lock receptacle. Photocell by others.
- Egress adapter shall require an auxiliary 120 volt supply for operation of an integral MR16 lamp in the event of emergency. The lamp may be aimed and locked into position with an adjustment range of 15°-45°. Adapter shall have a socket that accepts miniature bi-pin MR16 lamps up to 50 watts, lamp by others.

SERVICING

- Luminaire shall have tool-less service access to the gear compartment. Driver and surge suppressor shall be mounted to a prewired tray with quick disconnects that may be removed from the gear compartment.

ARM MOUNTING

- Luminaire shall slip over mounting arm and secured with three stainless steel 5/16-18 set screws.

FINISH

- Luminaire finish shall consist of a five stage pretreatment regimen with a polymer primer sealer, oven dry off, and top coated with a thermoset super TGIC polyester powder coat finish.
- Luminaire finish shall meet the AAMA 605 2 performance specification which includes passing a 3000 hour salt spray test for corrosion resistance.

CERTIFICATION

- Luminaire shall be listed with ETL for outdoor, wet location use, UL1598 UL 8750 and Canadian CSA Std. C22 2 no.250.

WARRANTY / TERMS AND CONDITIONS OF SALE

Download:

<http://www.hubbellighting.com/resources/warranty/>

LED Lighting Facts
A Program of the U.S. DOE

Light Output (Lumens)	4949
Watts	75.47
Lumens per Watt (Efficacy)	65
Color Accuracy Color Rendering Index (CRI)	75

Light Color
Measured Color Temperature (K): 4162 (Bright White)

Warm White 2700K | Bright White 4162K | Daylight 5000K

All results are according to IESNA's LM-79-0202. Approval Required for the Electrical and Photometric Testing of Solid State Lighting. The U.S. Department of Energy (DOE) reserves the right to audit and re-audit results.

Visit www.lightingfacts.com for the Label Reference Guide.

Registration Number: ZECM-139012 (07/28/2013)
Model Number: PROV-T2-32LED-3K-450
Type: Luminaire Area: Residential



ARCHITECTURAL AREA LIGHTING
16555 East Gale Ave. | City of Industry | CA 91745
P 626 968 5666 | F 626 369 2695 | www.aal.net
Copyright © 2014 Rev 2.15

JOB
TYPE
NOTES

Submitted by LEESMAN LIGHTING

Job Name:
Miami U - Hahne Hall - LEE15-23278

Catalog Number:
PROV-T2-32LED-3K-450-BLK-HSS-
WMA56

Notes:

Type:

W1

LEE15-23278

WMA56- Period Wall Mount Arm

TYPE

1. ARM

2. COLOR



WMA56

1. ARM

WMA56 (Weight: 10 lbs.)

2. COLOR

- | | |
|---|---|
| <input type="checkbox"/> AWT (Acrylic White) | <input type="checkbox"/> CRT (Corten) |
| <input checked="" type="checkbox"/> BLK (Black) | <input type="checkbox"/> MAL (Matte Aluminum) |
| <input type="checkbox"/> MTB (Matte Black) | <input type="checkbox"/> MDG (Medium Grey) |
| <input type="checkbox"/> DGN (Dark Green) | <input type="checkbox"/> ATG (Antique Green) |
| <input type="checkbox"/> DBZ (Dark Bronze) | <input type="checkbox"/> LGY (Light Grey) |
| <input type="checkbox"/> WRZ (Weathered Bronze) | <input type="checkbox"/> RAL/PREMIUM |
| <input type="checkbox"/> BRM (Metallic Bronze) | COLOR (Provide RAL) |
| <input type="checkbox"/> VBL (Verde Blue) | <input type="checkbox"/> CUSTOM COLOR |
| | (Provide color chip for matching) |

DIMENSIONS

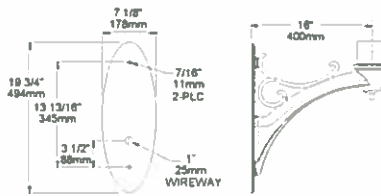

Note: Back plate is welded to the arm.

WMA56

SPECIFICATIONS

The arm shall be of one piece unitized aluminum construction, fully welded and assembled. The back plate shall be one piece cast aluminum. The arm shall be prewired with a quick connector for easy installation.

The arm shall have a cast aluminum fitter welded to the top of the arm(s) for attaching the fixture. The fixture shall be mounted with three stainless steel bolts through the top of the arm fitter into the fixture. The attachment point shall have a silicone pad for sealing the fixture to arm connection.

Mounting hardware and J-box by others

JOB _____
 TYPE _____
 NOTES _____



ARCHITECTURAL AREA LIGHTING
 16555 East Gale Ave. | City of Industry | CA 91745
 P 626 968 5666 | F 626 369 2695 | www.aal.net
 Copyright © 2012 | REV 6 12



PROJECT NAME: _____ CATALOG NUMBER: _____

NOTES: _____ FIXTURE SCHEDULE: _____

LED WALLMAX
LARGE WALL PACK: FULL CUTOFF
 MLLWP40LED50DS, MLLWP70LED50DS



MLLWP40LED50DS



MLLWP70LED50DS

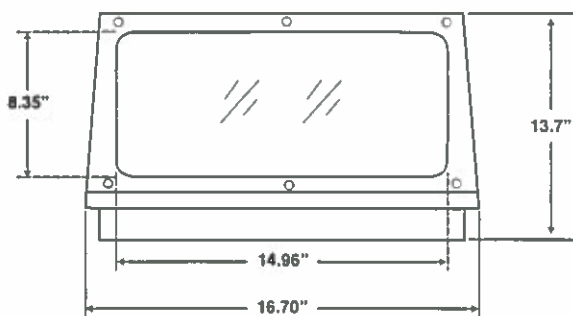
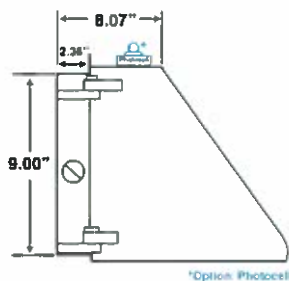

PRODUCT DESCRIPTION:

MaxLite's Wall Packs meet full cut off criteria established by the IESNA. Fixture can mount to electrical box or direct to wall.

FEATURES:

- Replaces up to 250 Watt Metal Halide
- CCT 5000K
- Self-contained driver
- Maintenance free; no UV
- Dusk To Dawn / Occupancy sensor compatible
- Can mount on electrical box or direct to wall
- LM-79/80 data available
- 5 Year Limited Warranty
- 20W and 30W models available

CONTROLS:

120VAC/208-277VAC Photocontrol: Voltage-specific photocontrols power the fixture when light levels reach 20 lux or below, and turn it off at 30 lux or higher. Operating temperature of -30°F-120°F. Photocell mounted externally.

Motion/Daylight Sensor: 0-10V microwave-based motion sensor with integral photocontrol, allowing for three output states: 100%; 10/20/30/50% output, or 0% output. Detection area, hold time, daylight threshold, and dimming level all have DIP switches. Operating temperature of -31°F-158 F. At its maximum mounting height of 32 feet, the sensor can detect motion up to 30 feet away. Sensor mounted internally, behind glass.

MODEL SELECTION (Full list of order codes on pg. 2)

Typical order example: MLLWP70LED50DS

MLLWP	LED50	DS	COLOR		CONTROLS	VOLTAGE	EMERGENCY BACKUP
FAMILY	WATTAGE (NOMINAL)	TECH.	STYLE	COLOR	CONTROLS	VOLTAGE	EMERGENCY BACKUP
MLLWP= Large Wall Pack 40= 40W replaces up to 175W MH 70= 55W replaces up to 250W MH	LED50= LED ↑	DS= Full Cutoff ↑	OMIT= Bronze (Std) W= White ¹	(OMIT)= None PC12= 120V Photocontrol 277V Photocontrol MS4= Motion/Daylight Sensor (Hi/Low/Off)	(OMIT)= 120-277V (Std) UH= 347-480V	(OMIT)= None EM= Emergency Battery Backup	

NOTES:

- ¹ Consult factory for lead time
- In the event of a power failure, the battery backup units switch to emergency mode (700 lumen output) and operates the fixture for a minimum of 90 minutes



LED WALLMAX
LARGE WALL PACK: FULL CUTOFF
 MLLWP40LED50DS, MLLWP70LED50DS

SPECIFICATIONS:

ITEM	SPECIFICATION	MLLWP40LED50		MLLWP70LED50	
		DETAILS		DETAILS	
GENERAL PERFORMANCE	Input Power (W)	35		52	
	Lumens Delivered (lm)	3350		4900	
	Efficacy (lm/W)	96		94	
	CRI	≥80			
	Lumen Maintenance (L70, TM-21 @ 25°C)	≥100,000		≥95,000	
	Color Temperature	5000K			
	Spacing Criteria	Available Upon Request			
	Color Consistency	Proprietary binning for uniform color			
ELECTRICAL	Power Factor (120V/277V)	≥0.99/≥0.95		≥0.99/≥0.92	
	Input Voltage	120-277V standard			
PHYSICAL	Weight	12.8 lbs		14.1 lbs	
	Housing	Aluminum			
	Lens	Tempered Glass			
	Mounting	Fits electrical box or mount directly			
	Operating Temperature	-30°F to 130°F			
CERTIFICATION	Humidity	20-85% RH, non-condensing			
	Certification	cETLus, FCC, LM79, LM80			
	Material Usage	RoHS compliant; no mercury			
	Environment	Outdoor wet location			
	Warranty	5 years			

Lighting layouts and spacing criteria available upon request

ORDERING*:

ORDER CODE	MODEL NUMBER	OPTIONS	FINISH	VOLTAGE	WATTAGE	CCT
70877	MLLWP40LED50DS	None	Bronze	120-277V	35	5000K
71390	MLLWP40LED50DSPC12	120V Photocontrol	Bronze			
73504	MLLWP40LED50DSPC12EM	120V Photocontrol; Emergency Battery Backup	Bronze			
71389	MLLWP40LED50DSPC27	277V Photocontrol	Bronze			
73821	MLLWP40LED50DSUH	None	Bronze			
71131	MLLWP40LED50DSW	None	White	120-277V	52	
74144	MLLWP40LED50DSMS4	Motion/Daylight Sensor	Bronze			
71136	MLLWP70LED50DS	None	Bronze			
73591	MLLWP70LED50DSEM	Emergency Battery Backup	Bronze			
71392	MLLWP70LED50DSPC12	120V Photocontrol	Bronze			
71391	MLLWP70LED50DSPC27	277V Photocontrol	Bronze	120-277V	52	
71132	MLLWP70LED50DSW	None	White			
74143	MLLWP70LED50DSMS4	Motion/Daylight Sensor	Bronze			
73850	MLLWP70LED50DSWPC12	120V Photocontrol	White			

*Please contact your MaxLite representative to order products that don't have order codes listed here.



LED WALLMAX
LARGE WALL PACK: FULL CUTOFF
MLLWP40LED50DS, MLLWP70LED50DS

CONSTRUCTION:

Fixture: Heavy-duty cast aluminum one-piece housing; polyester powder coat paint; rust and corrosion proof. Fixture is sealed to be dirt and insect proof.

Lens: High quality tempered glass

LED Module: Copper plating to provide high thermal transfer rate minimizing junction temperature of LED.

Finish: Dark Bronze or Textured White

CALIFORNIA TITLE 24 COMPLIANCE:

MLLWP40LED50DSMS4: Photocontrol or outdoor astronomical time switch required to power off fixture when daylight is available — section 132(c)
At ≤ 24 ft. mounting height, motion sensor must dim fixture by at least 40-80% — section 132(c)

MLLWP70LED50DSMS4: Photocontrol or outdoor astronomical time switch required to power off fixture when daylight is available — section 132(c)
At ≤ 24 ft. mounting height, motion sensor must dim fixture by at least 40-80% — section 132(c)



Project 15-20238-4
 MIAMI UNIVERSITY HAHNE HALL
 Submitted By
 KING LIGHTING INC

Catalog Number
 LRP W 1 RMR 120/277
 Notes

Typ#

X1



FEATURES & SPECIFICATIONS

INTENDED USE — Suitable for architectural applications where aesthetics and superior performance are required.

CONSTRUCTION — High-polish, injection-molded virgin acrylic panel, ultrasonically welded to eliminate visible hardware. Graduated depth of molded letters provides uniform light distribution on graphics. Standard housing finish is brushed aluminum.

Precision-molded, textured letters — 6" high with 3/4" stroke, with 100 ft viewing distance rating, based upon UL924 standard. Chevron indicator direction must be specified.

Recessed rough-in section constructed of 20-gauge, die-formed galvanized steel.

Extruded aluminum housing trim mounts flush onto wall or ceiling.

Mounting canopy for top mount is constructed of extruded aluminum to match housing finish.

OPTICS — LEDs mounted on printed circuit board. The typical life of the exit LED lamp is 10 years.

Low energy consumption — only 1.5W for 120V single-face red sign; 1.2W for 120V single-face green sign.

INSTALLATION — Recessed mount — rough-in section for back, ceiling or end mounting. Fits into minimum wall or ceiling opening 13-5/8" L x 4-1/2" W x 3-1/8" D.

Adjustable T-bar hangers adapt mounting tray for mounting in suspended ceilings or variable-size framed openings. Trim ring has 3/4" variable depth adjustment to ensure flush fit against surface of wall or ceiling.

Plug-in wire connections and self-captive mounting screws for mounting panel/trim to rough-in section.

Top mount (TM) — low-profile mounting canopy attaches exit to J-box. No rough-in section required.

LISTINGS — UL listed. Non-IC recessed mounting. Meets UL 924, NFPA 101 (current Life Safety Code), NEC and OSHA illumination standards, and State of Minnesota requirements for less than 20W energy consumption. Listed and labeled to comply with Canadian Standards C-860 and C-22.2 No. 9 (see options). NEMA Premium certified.

WARRANTY — 5-year limited warranty, including lamps. Complete warranty terms located at www.aculitybrands.com/customerresources/terms_and_conditions.aspx

All life safety equipment, including emergency lighting for path of egress must be maintained, serviced, and tested in accordance with all National Fire Protection Association (NFPA) and local codes. Failure to perform the required maintenance, service, or testing could jeopardize the safety of occupants and will void all warranties.

Actual performance may differ as a result of end user environment and application.

Note: Specifications subject to change without notice.



PRECISE[®]
 COLLECTION

Edge-Lit Exits

LRP

LED LAMPS RECESSED OR TOP MOUNT



ORDERING INFORMATION

For shortest lead times, configure products using **bolded options**.

Example: LRP 2 RMR DA 120/277

LRP	W	1	RMR	Directional Indicators ³	120/277
Family	Housing color	Number of faces	Letters/background		Input voltage ▶▶▶
LRP LED	(blank) Brushed aluminum W White B Black BZ Bronze BS Polished brass CR Chrome U Unfinished	1 Single face 2 Double face	RW Red on white RC Red on clear (single face only) ² RMR Red on mirror ^{1,2} GW Green on white ¹ GC Green on clear (single face only) ¹ GMR Green on mirror ^{1,2}	(blank) None LA Left ⁴ RA Right ⁴ LRA Left and right DA Double face ⁵	120/277 Dual voltage ⁶ 120/347 Dual voltage ⁶

Mounting	Item type	Options ⁴
(blank) Recessed ceiling or back mount EM Recessed end mount TM Top mount ⁷	(blank) Complete exit panel and rough-in section PNL Panel assembly only	FI Fire alarm interface ^{8,9} X2 Lamp boards wired on two separate circuits (specify 120V or 277V) ¹⁰ CSA Listed and labeled to comply with Canadian Standards

Accessories: Order as separate items.	
ELA LCRIS	LED rough-in section (supplied standard with recessed exit unless PNL suffix is specified; order ELA LCRIS only if needed for early installation). ⁴
ELA US12	12" pendant-mount kit. Mounting canopy is brushed aluminum. To order white or black canopy, add W or B to catalog number. Example: ELA W US12. To order 24" or 36" lengths, add 24 or 36 to catalog number. Example: ELA US24. See spec sheet ELA StemKits . ¹⁰

Notes

- Not available with CSA option.
- Simulates clear background for double-face exits.
- See chart on back for more information.
- Only available with single face.
- Only available with double face.
- Only available with CSA option.
- No rough-in section required. Attaches directly to J-box.
- When ordering recessed rough-in separately, all options must be included with rough-in nomenclature. Example: ELA LRS 120 X2.
- Not available with top-mount exits.
- Top-mount exits only.



Project 15-20238-4
 MIAMI UNIVERSITY HAHNE HALL
 Submitted By
 KING LIGHTING INC

Catalog Number
 LRP W 1 RMR 120/277

Notes

Type

X1

LRP Precise® LED Exit Signs

SPECIFICATIONS

ELECTRICAL					
Primary Circuit					
Type	Typical LED life ¹	Supply voltage	Number of faces	Input watts	Max. amps
Red	10 years	120	1	1.5	.087
		277	1	1.8	.089
		347	1	2.2	.107
Red	10 years	120	2	3.1	.178
		277	2	3.4	.180
		347	2	4.1	.220
Green	10 years	120	1	1.2	.064
		277	1	1.3	.062
Green	10 years	120	2	2.0	.06
		277	2	2.3	.06

Notes
 1 Based on continuous operation. The typical life of the exit LED lamp is 10 years.

MOUNTING

All dimensions are in inches (centimeters).
 Shipping weight for panel: 5 lbs. (2.3 kgs.)
 Shipping weight for rough-in section: 4.6 lbs. (2.1 kgs.)

RECESSED

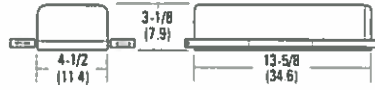

Rough-In Section

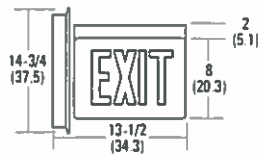

End Mount

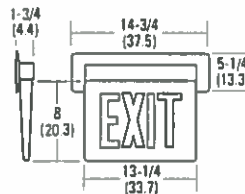

Back Mount

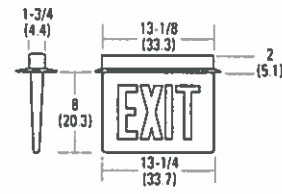

Ceiling Mount

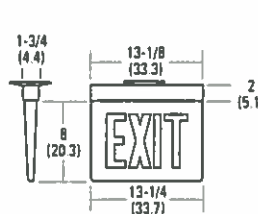

Top Mount

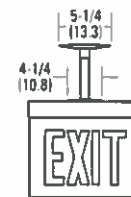

With Pendant Mounting kit

Directional Indicators

Specification (add to catalog number)	Graphics	
	Back	Front
LA		
RA		
LRA (single face)		
DA		
LRA (double face)		

KEY FEATURES

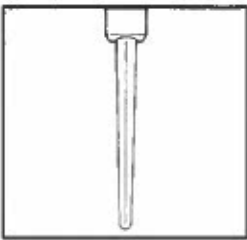

Unique wedge-shaped panel design concentrates light for uniform letter illumination.



Trim fits flush against wall or ceiling for clean, attractive appearance.

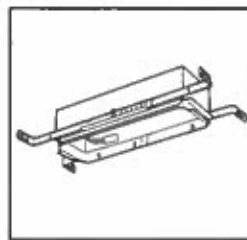

Small rough-in section.

	Project 15-20238-4 MIAMI UNIVERSITY HAHNE HALL Submitted By KING LIGHTING INC	Catalog Number LRP W 2 RMR 120/277 Notes	Type <h1 style="text-align: center;">X2</h1>
---	---	---	---



FEATURES & SPECIFICATIONS

INTENDED USE — Suitable for architectural applications where aesthetics and superior performance are required.

CONSTRUCTION — High-polish, injection-molded virgin acrylic panel, ultrasonically welded to eliminate visible hardware. Graduated depth of molded letters provides uniform light distribution on graphics. Standard housing finish is brushed aluminum.

Precision-molded, textured letters — 6" high with 3/4" stroke, with 100 ft viewing distance rating, based upon UL924 standard. Chevron indicator direction must be specified.

Recessed rough-in section constructed of 20-gauge, die-formed galvanized steel.

Extruded aluminum housing trim mounts flush onto wall or ceiling.

Mounting canopy for top mount is constructed of extruded aluminum to match housing finish.

OPTICS — LEDs mounted on printed circuit board. The typical life of the exit LED lamp is 10 years.

Low energy consumption — only 1.5W for 120V single-face red sign; 1.2W for 120V single-face green sign.

INSTALLATION — Recessed mount — rough-in section for back, ceiling or end mounting. Fits into minimum wall or ceiling opening 13-5/8" L x 4-1/2" W x 3-1/8" D.

Adjustable T-bar hangers adapt mounting tray for mounting in suspended ceilings or variable-size framed openings. Trim ring has 3/4" variable depth adjustment to ensure flush fit against surface of wall or ceiling.

Plug-in wire connections and self-captive mounting screws for mounting panel/trim to rough-in section.

Top mount (TM) — low-profile mounting canopy attaches exit to J-box. No rough-in section required.

LISTINGS — UL listed. Non-IC recessed mounting. Meets UL 924, NFPA 101 (current Life Safety Code), NEC and OSHA Illumination standards, and State of Minnesota requirements for less than 20W energy consumption. Listed and labeled to comply with Canadian Standards C-860 and C-22.2 No. 9 (see options). NEMA Premium certified.

WARRANTY — 5-year limited warranty, including lamps. Complete warranty terms located at www.arslybrands.com/customerresources/terms_and_conditions.aspx

All life safety equipment, including emergency lighting for path of egress must be maintained, serviced, and tested in accordance with all National Fire Protection Association (NFPA) and local codes. Failure to perform the required maintenance, service, or testing could jeopardize the safety of occupants and will void all warranties.

Actual performance may differ as a result of end-user environment and application.

Note: Specifications subject to change without notice.



PRECISE[®]
COLLECTION

Edge-Lit Exits

LRP

LED LAMPS RECESSED OR TOP MOUNT



ORDERING INFORMATION

For shortest lead times, configure products using **bolded options**.

Example: LRP 2 RMR DA 120/277

LRP	W	2	RMR	Directional Indicators ¹	120/277
Family	Housing color	Number of faces	Letters/background		Input voltage ▶▶▶
LRP LED	(blank) Brushed aluminum W White B Black BZ Bronze BS Polished brass CR Chrome U Unfinished	1 Single face 2 Double face	RW Red on white RC Red on clear (single face only) ¹ RMR Red on mirror ^{1,2} GW Green on white ¹ GC Green on clear (single face only) ¹ GMR Green on mirror ^{1,2}	(blank) None LA Left ⁴ RA Right ⁴ LRA Left and right DA Double face ³	120/277 Dual voltage ¹ 120/347 Dual voltage ¹

Mounting	Item type	Options ¹
(blank) Recessed ceiling or back mount EM Recessed end mount TM Top mount ⁷	(blank) Complete exit panel and rough-in section PNL Panel assembly only	FI Fire alarm interface ^{1,9} X2 Lamp boards wired on two separate circuits (specify 120V or 277V) ⁹ CSA Listed and labeled to comply with Canadian Standards

Accessories: Order as separate items.	
ELA LCRIS	LED rough-in section (supplied standard with recessed exit unless PNL suffix is specified; order ELA LCRIS only if needed for early installation). ⁹
ELA US12	12" pendant-mount kit. Mounting canopy is brushed aluminum. To order white or black canopy, add W or B to catalog number. Example: ELA W US12. To order 24" or 36" lengths, add 24 or 36 to catalog number. Example: ELA US24. See spec sheet ELA-ItemKits . ¹⁰

Notes

- 1 Not available with CSA option.
- 2 Simulates clear background for double-face exits.
- 3 See chart on back for more information.
- 4 Only available with single face.
- 5 Only available with double face.
- 6 Only available with CSA option.
- 7 No rough-in section required. Attaches directly to J-box.
- 8 When ordering recessed rough-in separately, all options must be included with rough-in nomenclature. Example: ELA LRS 120 X2.
- 9 Not available with top-mount exits.
- 10 Top-mount exits only.



Project 15-20238-4
 MIAMI UNIVERSITY HAHNE HALL
 Submitted By
 KING LIGHTING INC

Catalog Number
 LRP W 2 RMR 120/277
 Notes

Type

X2

LRP Precise® LED Exit Signs

SPECIFICATIONS

ELECTRICAL					
Primary Circuit					
Type	Typical LED life ¹	Supply voltage	Number of faces	Input watts	Max. amps
Red	10 years	120	1	1.5	.087
		277	1	1.8	.089
		347	1	2.2	.107
Red	10 years	120	2	3.1	.178
		277	2	3.4	.180
		347	2	4.1	.220
Green	10 years	120	1	1.2	.064
		277	1	1.3	.062
Green	10 years	120	2	2.0	.06
		277	2	2.3	.06

Notes
 1 Based on continuous operation. The typical life of the exit LED lamp is 10 years.

MOUNTING

All dimensions are in inches (centimeters).
 Shipping weight for panel: 5 lbs. (2.3 kgs.)
 Shipping weight for rough-in section: 4.6 lbs. (2.1 kgs.)

RECESSED

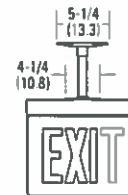
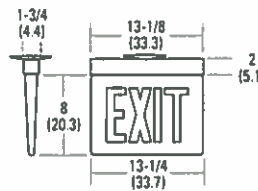
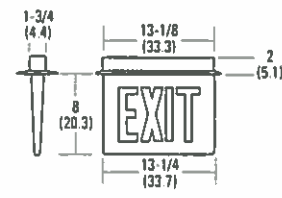
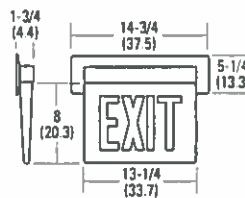
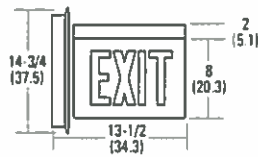
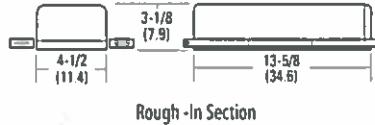

Directional Indicators

Specification (add to catalog number)	Graphics	
	Back	Front
LA		
RA		
LRA (single face)		
DA		
LRA (double face)		

KEY FEATURES

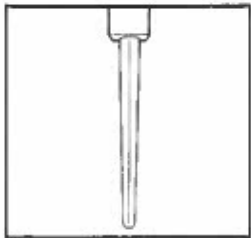

Unique wedge-shaped panel design concentrates light for uniform letter illumination.



Trim fits flush against wall or ceiling for clean, attractive appearance.

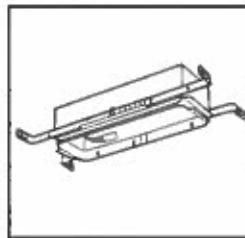

Small rough-in section.

	Project 15-20238-4 MIAMI UNIVERSITY HAHNE HALL Submitted By KING LIGHTING INC	Catalog Number LQM S W 3 R 120/277 M6 Notes	Type <h1 style="text-align: center;">X3</h1>
---	---	---	--



FEATURES & SPECIFICATIONS

INTENDED USE — Ideal for applications requiring attractive, quick-installation exit signs and low energy consumption.

CONSTRUCTION — Engineering-grade thermoplastic housing is impact-resistant, scratch-resistant, and corrosion-proof. UL94V-0 flame rating. UV-stable resin resists discoloration from natural and man-made light sources.

Rugged unibody housing snaps together with no additional mechanical fasteners. Faceplate and back cover are interchangeable on housing. Positive snap-fit tabs hold faceplate securely, yet easily removable for lamp compartment access.

Universal directional Chevron Inserts are easily removed and reinserted. Uniform illumination without shadows or hot spots. Reinforced, impact-resistant color panels. Letters 6" high with 3/4" stroke, with 100 ft. viewing distance rating, based upon UL924 standards.

U.S. Patent No. 5,526,251; 5,611,163; 5,739,639; 5,954,423; 5,988,825; 6,152,581; D383,501; D495,751 and 6,502,044. Other patents pending.

OPTICS — LEDs mounted on printed circuit boards. Low energy consumption – less than one watt. LED lamp operates in normal (AC input) and emergency (DC input) modes.

The typical life of the exit LED lamp is 10 years.

ELECTRICAL — Low-voltage disconnect prevents excessively deep discharge that can permanently damage battery. Conveniently located test switch and LED provide visual and manual means of monitoring system.

Constant-current series charger minimizes energy consumption and provides low operating costs. Printed circuit boards are 100% quality tested during manufacturing. Current-limiting charger circuitry protects printed circuit boards from shorts.

AC/LV reset (line latch) allows battery connection before AC power is applied and aids in preventing battery damage from deep discharge.

Crystal oscillator timing system with watchdog protection for precision accuracy.

Brownout protection is automatically switched to emergency mode when supply voltage drops below 80% of nominal.

Battery: Sealed, maintenance-free nickel-cadmium battery delivers 90-minutes capacity to emergency lamps. Two-state constant-current charge maximizes battery life and automatically recharges after battery discharge.

DiagnosTics: Single-point microcomputer control for all electronic features.

Single multi-chromatic LED indicator to display two-state charging, test activation and three-state diagnostic status.

Test switch provides manual activation of 30-second diagnostic testing for on-demand visual inspection. Self-diagnostic testing for five minutes every 30 days and 30 minutes every six months and 90 mins annually with WRS.

Diagnostic evaluation of LED light source, AC to DC transfer, charging and battery condition. Continuously monitors AC functionality.

INSTALLATION — Universal (top-, end-, or back-) mounting. Easily removed mounting knockouts. J-box pattern on back panel. Housing snaps to canopy with four positive-locking tabs. Cam-locking pin tightly secures housing to canopy.

Ships standard with additional face plate.

LISTINGS — UL damp location listed 50°-104°F (10°-40°C) standard. NOM Certified (see options). Meets UL924, NFPA 101 (current Life Safety Code), NEC and OSHA illumination standards. NEMA Premium certified. Meets all applicable FCC requirements.



Thermoplastic Exits

LQM

LED LAMPS



Specifications

Length: 11-3/4 (29.8)
 Depth: 2 (5.1)
 Height: 7-5/8 (19.3)
 Weight: 2.6 lbs (1.2 kgs)

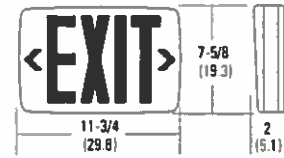

All dimensions are inches (centimeters) unless otherwise specified.

WARRANTY — 5-year limited warranty. Complete warranty terms located at

www.aculibrands.com/customer-resources/terms_and_conditions.asp

Actual performance may differ as a result of end-user environment and application.

Note: Specifications subject to change without notice.

ORDERING INFORMATION

For shortest lead times, configure product using **bolded options**.

Example: LQM S W 3 R 120/277 EL N

LQM	S	W	3	R	120/277		
Family	Face type	Housing color	Number of faces	Letter color	Input voltage ¹	Operation	Options
LQM	S Stencil P Panel ¹	(blank) Black W White	3 Single face with extra faceplate and color panel	R Red G Green	120/277 Dual voltage	(blank) AC only X2 Primary and secondary AC inputs provided ¹ EL N Nickel cadmium battery	(blank) None NOM NOM certified for Mexico ⁴ SD Self-diagnostics ⁵ SDRIFA Self-diagnostics, fire alarm flashing interface and flashing emergency operation and intermittent audible alarm (one flash/one second) ⁵ WRS Dual voltage 120/277, Ni-Cad battery back up and self-diagnostic with FIDO wireless reporting system capability ⁶

Notes

- 1 Only available in custom signage. See spec sheet, [Custom Signage](#).
- 2 Some special voltages available. Consult factory.
- 3 Must specify input voltage 120 or 277. Not available with other options.
- 4 Available with stencil or panel faces in white housing. Not available with WRS option.
- 5 Only available with EL N operation.
- 6 See [LHQM LED](#) spec sheet (LHQM LED RD WRS).
- 7 See spec sheet [ELA-WG](#).
- 8 See spec sheet [ELA-STEMITS](#).

Accessories: Order as separate item.

ELA WG1 Back-mount wireguard ¹	ELA WGEK End-mount wireguard ¹
ELA WGEXT Top-mount wireguard ¹	ELA LQMUS12 12" stem kit ⁴



Project 15-20238-4
 MIAMI UNIVERSITY HAHNE HALL
 Submitted By
 KING LIGHTING INC

Catalog Number
 LQM S W 3 R 120/277 M6

Notes

Type

X3

LQM LED, Quantum®

SPECIFICATIONS

ELECTRICAL				
Primary Circuit				
Type ¹	Typical LED life ²	Supply voltage	Input watts	Max. amps
Red LED AC Only	10 years	120	.62	.05
		277	.69	.06
Green LED AC Only	10 years	120	.62	.05
		277	.74	.06
Red LED Emergency	10 years	120	.71	.05
		277	.92	.06
Green LED Emergency	10 years	120	.66	.05
		277	.70	.06

BATTERY				
Nickel Cadmium				
Voltage	Shelf life ³	Typical life ³	Maintenance ⁴	Optimum temperature ⁵
1.2	3 years	7-9 years	none	50°F - 104°F (10°C - 40°C)

Notes

- LED lamps operate in normal (AC input) and emergency (DC input) modes.
- Based on continuous operation. The typical life of the exit LED lamp is 10 years.
- At 77°F (25°C).
- All life safety equipment, including emergency lighting for path of egress must be maintained, serviced and tested in accordance with all National Fire Protection Association (NFPA) and local codes. Failure to perform the required maintenance, service, or testing could jeopardize the safety of occupants and will void all warranties.
- Optimum ambient temperature range where unit will provide capacity for 90 minutes. Higher and lower temperatures affect life and capacity. Consult factory for detailed information.

MOUNTING

All dimensions are inches (centimeters) unless otherwise specified.
 Shipping weight: 2.6 lbs. (1.2 kgs.)

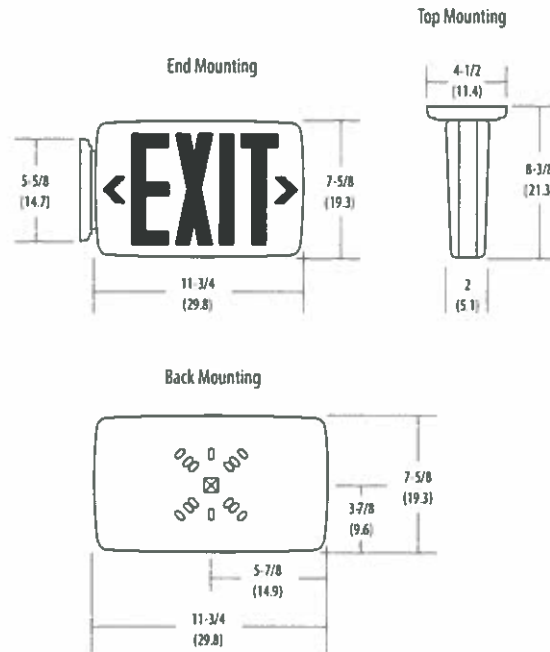



Project 15-20238-4
 MIAMI UNIVERSITY HAHNE HALL
 Submitted By
 KING LIGHTING INC

Catalog Number
 LQM S W 3 R 120/277 M6
 Notes

Type

X4



FEATURES & SPECIFICATIONS

INTENDED USE — Ideal for applications requiring attractive, quick installation exit signs and low energy consumption.

CONSTRUCTION — Engineering-grade thermoplastic housing is impact-resistant, scratch-resistant, and corrosion-proof. UL94V-0 flame rating. UV-stable resin resists discoloration from natural and man-made light sources.

Rugged unibody housing snaps together with no additional mechanical fasteners. Faceplate and back cover are interchangeable on housing. Positive snap-fit tabs hold faceplate securely, yet easily removable for lamp compartment access.

Universal directional Chevron inserts are easily removed and reinserted. Uniform illumination without shadows or hot spots. Reinforced, impact-resistant color panels. Letters: 6" high with 3/4" stroke, with 100 ft. viewing distance rating, based upon UL924 standards.

U.S. Patent No. 5,526,251; 5,611,163; 5,739,639; 5,954,423; 5,988,825; 6,152,581; D383,501; D495,751 and 6,502,044. Other patents pending.

OPTICS — LEDs mounted on printed circuit boards. Low energy consumption – less than one watt. LED lamp operates in normal (AC Input) and emergency (DC Input) modes.

The typical life of the exit LED lamp is 10 years.

ELECTRICAL — Low-voltage disconnect prevents excessively deep discharge that can permanently damage battery. Conveniently located test switch and LED provide visual and manual means of monitoring system.

Constant-current series charger minimizes energy consumption and provides low operating costs. Printed circuit boards are 100% quality tested during manufacturing. Current-limiting charger circuitry protects printed circuit boards from shorts.

AC/AV reset (line latch) allows battery connection before AC power is applied and aids in preventing battery damage from deep discharge.

Crystal oscillator timing system with watchdog protection for precision accuracy.

Brownout protection is automatically switched to emergency mode when supply voltage drops below 80% of nominal.

Battery: Sealed, maintenance-free nickel-cadmium battery delivers 90-minutes capacity to emergency lamps. Two-state constant-current charge maximizes battery life and automatically recharges after battery discharge.

Diagnostics: Single-point microcomputer control for all electronic features.

Single multi-chromatic LED Indicator to display two-state charging, test activation and three-state diagnostic status.

Test switch provides manual activation of 30-second diagnostic testing for on-demand visual inspection. Self-diagnostic testing for five minutes every 30 days and 30 minutes every six months and 90 mins annually with WRS.

Diagnostic evaluation of LED light source, AC to DC transfer, charging and battery condition. Continuously monitors AC functionality.

INSTALLATION — Universal (top-, end-, or back-) mounting. Easily removed mounting knockouts. J-box pattern on back panel. Housing snaps to canopy with four positive-locking tabs. Cam-locking pin tightly secures housing to canopy.

Ships standard with additional face plate.

LISTINGS — UL damp location listed 50°–104°F (10°–40°C) standard. NOM Certified (see options). Meets UL924, NFPA 101 (current Life Safety Code), NEC and OSHA illumination standards. NEMA Premium certified. Meets all applicable FCC requirements.



Thermoplastic Exits

LQM

LED LAMPS



Specifications
 Length: 11-3/4 (29.8)
 Depth: 2 (5.1)
 Height: 7-5/8 (19.3)
 Weight: 2.6 lbs (1.2 kgs)



All dimensions are inches (centimeters) unless otherwise specified.

WARRANTY — 5-year limited warranty. Complete warranty terms located at www.aclulbrands.com/CustomersResources/terms_and_conditions.aspx. Actual performance may differ as a result of end-user environment and application. Note: Specifications subject to change without notice.

ORDERING INFORMATION

For shortest lead times, configure product using **bolded options**.

Example: LQM S W 3 R 120/277 EL N

LQM	S	W	3	R	120/277		
Family	Face type	Housing color	Number of faces	Letter color	Input voltage ²	Operation	Options
LQM	S Stencil P Panel ¹	(blank) Black W White	3 Single face with extra faceplate and color panel	R Red G Green	120/277 Dual voltage	(blank) AC only X2 Primary and secondary AC inputs provided ¹ EL N Nickel cadmium battery	(blank) None NOM NOM certified for Mexico ⁴ SD Self-diagnostics ⁵ SDFIFA Self-diagnostics, fire alarm flashing interface and flashing emergency operation and intermittent audible alarm (one flash/one second) ³ WRS Dual voltage 120/277, Ni-Cad battery back up and self-diagnostic with FIDO wireless reporting system capability ⁶

Accessories: Order as separate item.

ELA WG1	Back-mount wireguard ⁷	ELA WGEKE	End-mount wireguard ⁷
ELA WGEXT	Top-mount wireguard ⁷	ELA LQMUS12	12" stem kit ⁸

Notes

- 1 Only available in custom signage. See spec sheet, [Custom Signage](#).
- 2 Some special voltages available. Consult factory.
- 3 Must specify input voltage 120 or 277. Not available with other options.
- 4 Available with stencil or panel faces in white housing. Not available with WRS option.
- 5 Only available with EL N operation.
- 6 See [LHOM LED](#) spec sheet (LHOM LED PD WRS).
- 7 See spec sheet [ELA WG](#).
- 8 See spec sheet [ELA StemKit](#).



Project 15-20238-4
 MIAMI UNIVERSITY HAHNE HALL
 Submitted By
 KING LIGHTING INC

Catalog Number
 LQM S W 3 R 120/277 M6

Notes

Type

X4

LQM LED, Quantum®

SPECIFICATIONS

ELECTRICAL				
Primary Circuit				
Type ¹	Typical LED life ²	Supply voltage	Input watts	Max. amps
Red LED AC Only	10 years	120	.62	.05
		277	.69	.06
Green LED AC Only	10 years	120	.62	.05
		277	.74	.06
Red LED Emergency	10 years	120	.71	.05
		277	.92	.06
Green LED Emergency	10 years	120	.66	.05
		277	.70	.06

BATTERY				
Nickel Cadmium				
Voltage	Shelf life ¹	Typical life ¹	Maintenance ⁴	Optimum temperature ⁵
1.2	3 years	7-9 years	none	50°F - 104°F (10°C - 40°C)

Notes

- LED lamps operate in normal (AC input) and emergency (DC input) modes.
- Based on continuous operation. The typical life of the exit LED lamp is 10 years.
- At 77°F (25°C).
- All life safety equipment, including emergency lighting for path of egress must be maintained, serviced and tested in accordance with all National Fire Protection Association (NFPA) and local codes. Failure to perform the required maintenance, service, or testing could jeopardize the safety of occupants and will void all warranties.
- Optimum ambient temperature range where unit will provide capacity for 90 minutes. Higher and lower temperatures affect life and capacity. Consult factory for detailed information.

MOUNTING

All dimensions are inches (centimeters) unless otherwise specified.
 Shipping weight: 2.6 lbs. (1.2 kgs.)

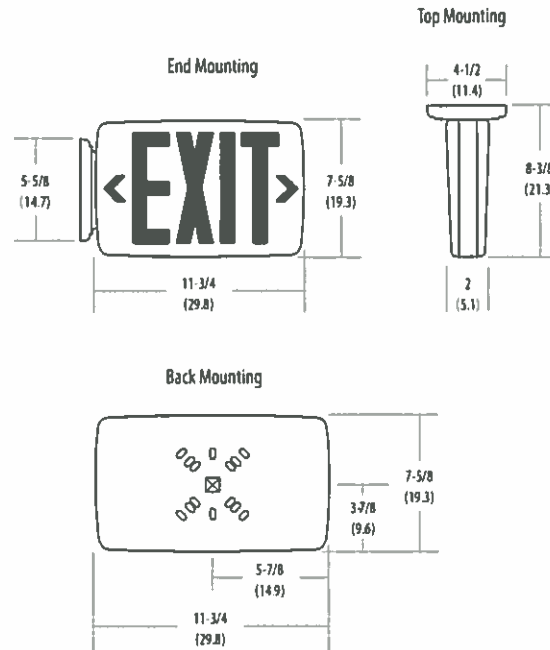

Submitted by LEESMAN LIGHTING



Job Name:
Miami U - Hahne Hall - LEE15-23278

Catalog Number:

PGF1P

Notes:

Type:

EM1

LEE15-23278



PGF1

High Performance LED Sconce

FEATURES

Application

The PGF1 is a maintenance-free indoor/outdoor die-cast architectural LED Sconce. It is wet location listed and offers pathway, perimeter or entry lighting at a mounting height of 8 to 10 feet.

Construction

Housing and mounting plate are constructed of 0.125" die-cast aluminum and the housing is fully gasketed. Lens is acrylic with 95% light transmission to reduce glare. The reflector is electro-polished aluminum with 95% reflectance. Housing is powder coated electro-deposition paint available in 2 colors. The PGF1 includes a field installable full cut-off shield to address "dark sky" compliant requirements. An optional 120VAC photo-control is also available.

Installation

Universal backplate knockouts for mounting to standard 3 1/2", 4" octagonal and 4" square electrical boxes. Backplate mounting is performed using installer supplied hardware. An adhesive-backed neoprene gasket is provided to ensure a waterproof seal. A 1/2" - 1/4 NPT threaded conduit opening is provided at the top of the enclosure and sealed with a closure plug. The housing "snaps" to the back plate by a "pin and socket" arrangement, and is secured with two Phillips head screws.

Electronics

Number of Lamps: 7 High Output LED's
Lamp Type: Solid State High Output LED's
Lamp Color: Cool White, 4300K
Total Lamp Output: 1067 Lumens
Lumen Maintenance: 50,000 hours
LED Light Engine: Constant current Driver meets UL1310 class 2 for SSL and FCC Class B, rated for 50,000 hours
Voltage Input: 120 to 277VAC, 50/60 Hz
Input Power Requirements: 177 watts
Fixture Efficacy: 60.3 Lumens per Watt

Compliances

CSA Certified to UL1598 for use in Wet locations

Warranty

Five-year full unit

Catalog Number

Comments

Type



Dark Bronze

Patent No.
D627,916



Platinum Silver

DIMENSIONS

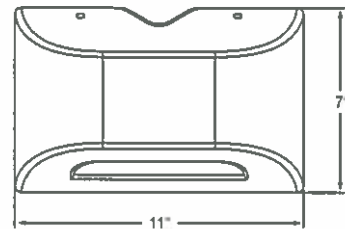

ORDERING GUIDE

PGF1

Series

Finish

Z - Dark Bronze

P - Platinum Silver

Options

-PC1 120VAC Photo-control

Dual-Lite • www.dual-lite.com

A Hubbell Lighting, Inc. brand with representatives' offices in principal cities throughout North America.
Copyright © Hubbell Lighting Inc., All Rights Reserved • Specifications subject to change without notice. • Printed in U.S.A.



Hubbell Lighting, Inc.

0603514 A 2/12

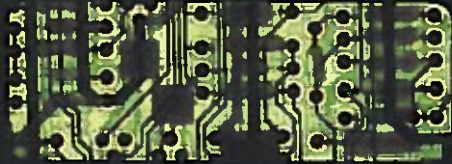

Custom Air Handlers
Reliable Integrated Frame Solutions

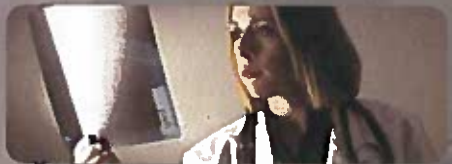

Custom-Engineered Air Handling Solutions



An air-handling manufacturer that can flex when you need flexibility is what being in the custom air handling business is all about. And by flex we don't mean in just a few components.

Challenges

- Configuring an air handler to address your unique needs
- Managing the tradeoffs in designing for energy efficiency, low sound, size, capacity, costs, and timetable
- Finding a company who can deliver

Recommendations

- Specify a Temtrol® ITF custom air handler

Benefits

- Single-source responsibility with major components designed and manufactured by Temtrol
- Gain access to Temtrol's 50+ years of manufacturing expertise and ideas for reliable performance
- Reduce construction cycle and total cost of ownership with FANWALL TECHNOLOGY®
- Custom-engineered designs to fit your application

Temtrol® has earned a reputation in the market for flexibility and performance. Delivering custom-engineered air-handling solutions since 1955, Temtrol invites you to meet with one of our representatives to discuss your unique needs. We'll design a unique solution to deliver the performance you need. Discuss. Design. Deliver.™ That is what we do.

- or optional four-inch fiberglass
- Complete welded structural steel base—a Temtrol tradition
- Close-cell sprayed foam insulation in the double bottom base structure ensures airtight and watertight performance
- Temtrol designed and manufactured ultra low-leak dampers with low torque requirements, and corrosion resistant construction
- Temtrol built cooling and heating coils of any arrangement and construction and engineered for long life
- Temtrol built energy-efficient fans—forward curve, backward inclined, air-foil, plug, and FANWALL TECHNOLOGY®



Temtrol air handler with a FANWALL® array can result in a reduction in footprint, sound levels, and energy usage.

New Temtrol Innovation

Keeping pace with shorter design and construction cycles is a challenge Temtrol takes seriously. Temtrol's model ITF air handler and multi-million dollar investment in new manufacturing technology, results in a flexible design that can meet the most challenging timeframe.

Key features of the model ITF air handler include:

- Unit dimensions in 1-inch increments for a custom fit
- A unitized mechanical frame, above the base, roll-formed from heavy gauge zinc coated steel, for long life
- The unitized frame offers complete flexibility in unit arrangements while promoting rigid airtight casings
- All panels are individually removable **without** affecting structural integrity
- Panel insulation includes three-inch R12

Breakthrough Technology from Temtrol

For the right application, Temtrol offers FANWALL TECHNOLOGY by HUNTAIR®. A FANWALL® air handler can reduce the AHU footprint as much as 50%, reduce low frequency sound levels—often eliminating external attenuation devices, maximize uptime with redundant fans, and lower energy costs with fans operating nearer their peak efficiency.

Contact a Temtrol® representative to learn more about our custom air-handling solutions.



Performance data you can trust from Temtrol's AMCA-accredited sound- and thermal-testing laboratory.



www.temtrol.com
temtrol@temtrol.com

Temtrol, Inc. has a policy of continuous product improvement and reserves the right to change design and specifications without notice.

©2007 Temtrol, Inc.
TEM-ITF-55-1
SEP 2007



Phone - 405-263-7286

Fax - 405-263-4924

JOB: MIAMI UNIVERSITY - NORTH QUAD AHUS

TEMTROL REP: ENVIRONMENTAL COMFORT, LLC.

ORDER NUMBER: T019959

GENERAL:

- ▣ *Factory fabricated (ITF) indoor air handling unit. (One piece construction unless noted by a demount on unit drawing). All units (single and multi-sectioned) ship fully assembled and sealed unless they exceed maximum shipping capacities. Multi-sectioned units, shipped in one piece, will require field disassembly by the installing contractor. All unit openings will be sealed for "shipping". Units will ship on an open flat bed trailer and require off loading within three (3) hours of arrival at the jobsite or be subjected to demurrage fees. Upon arrival, units shall be cleaned (if necessary) and inspected by the contractor. Damaged or missing components must be noted on the bill of lading. Units should be properly stored indoors per Temtrol Operation and Maintenance manual. If units are stored for an extended period of time, routine maintenance is required.*
- ▣ *Multi-sectioned units with factory furnished lights or electrical conduit will be furnished with flex connections at each demount. Electrical connections will be re-connected by installing contractor after the unit is reassembled and set in place.*
- ▣ *Right and left determined by facing in the direction of air flow with air hitting the back of your neck.*
- ▣ *All dimensions in inches.*
- ▣ *Steel grating provided over all floor penetrations where access is provided.*
- ▣ *The Air Handling Unit schedule indicates total static pressure only. All internal losses and available external static pressure are shown on the static pressure summary sheet in this submittal. Written verification of external static pressure is required by the engineer prior to release for production to prevent improper fan selection.*

UNIT BASE / FLOOR / FRAMEWORK: