

# **Interconnection System Impact Study Draft Report**

**June 25, 2009**

## **Iowa DPP Cycle 2 Group Thermal Study**

**H007: 41 MW Wind  
Delaware County, Iowa  
MISO Queue 39560-01**

**H078: 121 MW Wind  
Marshall County, Iowa  
MISO Queue 39619-02**

---

# Table of Contents

- Executive Summary ..... 3
- Summary of constraints: ..... 4
- 1.0 Introduction..... 5
- 2.0 Study Assumptions and Methodology ..... 5
  - 2.1 Study Assumptions ..... 5
  - 2.2 Steady State Analysis..... 5
    - 2.2.1 Thermal Analysis ..... 5
    - 2.2.2 Voltage Analysis..... 6
- 3.0 Model Development and Analysis ..... 6
  - 3.1 Impact of H007 & H078 on Facility Loadings ..... 7
  - 3.2 Impact of H007 & H078 on Bus Voltages..... 8
- 4.0 Constraint Mitigation ..... 9
- 5.0 Conclusions..... 9
- Appendix A - Case Development ..... 10
- Appendix B - Power Flow Results..... 23
- Appendix C - Multi-Element Contingencies ..... 24

## Executive Summary

This report contains results obtained from the Iowa DPP Cycle 2 System Impact Group Study (SIS) performed to evaluate the request to interconnect 41 MW of wind generation in Delaware County, IA and 121 MW of wind generation in Marshall County, IA. The purpose of this SIS is to identify steady-state thermal and voltage violations. The requested in-service date for H007 is December 2010 and for H078 is December 2012. Project H007 is proposed to be interconnected to the transmission system at the existing Edgewood 69 kV substation and project H078 is proposed to be interconnected to the transmission system by tapping the existing Marshalltown to Jasper 161 kV line. Both projects have requested Energy Resource Interconnection Service (ERIS).

Thermal analyses have been performed on powerflow cases representing 2013 summer peak and summer off-peak scenarios. The MN DPP Cycle 1 (November 2008) models were used as a starting point for these cases. The base cases used in this study include future transmission upgrades from MTEP 08 Appendix A and B. These transmission projects are listed in Appendix A of this report (Model Development). Projects in MTEP 08 Appendix B have not yet been studied through the MTEP cost-allocation process. If any of these projects do not get developed, as per the identified need (in MTEP), these interconnection requests would be reevaluated to determine if they are potentially responsible for the cost of those projects or appropriate alternatives.

Injection-related constraints, as defined in this study, refer to constraints that have a distribution factor (DF) of 20% or more and constraints at or caused by the loss of generator outlet. These constraints need to be mitigated in order for H007 & H078 to connect to the system. In addition, any stability and short circuit issues, uncovered in the System Impact Study, will have to be addressed as well. This analysis also looked at potential constraints that would limit the ability of the connecting generator to deliver its power to the system. These constraints are listed in the results as non-injection related, and they were defined by an overload with a DF cutoff of 5%.

The interconnection of the proposed projects did cause injection related constraints. Therefore, there seem to be limitations on the ability of the proposed generators to connect to the system. Moreover, the study also determined that the proposed generators impacted existing steady-state thermal violations as well as caused new line overloads to occur. While these criteria violations would not need mitigation before the generator can interconnect, these could potentially cause the operation of the plants to be restricted or curtailed.

Injection related constraints observed in the steady-state analysis along with a good faith, non-binding planning cost estimate for the required upgrades is provided below. These estimates would be further refined in the facilities study. The following transmission improvements were identified to mitigate the observed constraints:

### Required Upgrades for ERIS and corresponding planning cost estimates:

Constrained Facility	Facility Owner	Potential Mitigation	Project responsible for upgrade cost	H007 DF%	H078 DF%	Cost Estimate
Marshalltown – Jasper 161 kV line	ITC Midwest	Substation equipment (Wave Trap, relaying, CTs)	H078	5.20	52.77	\$70,000
Greely – Dundee 69 kV line	ITC Midwest	Substation equipment (CT, relaying)	H007	100	0	\$55,000

## Summary of constraints:

Analyses performed on the 2013 summer peak case indicated that there were no injection or non-injection related constraints caused by either the H007 & H078 interconnection requests.

The following injection and non-injection constraints were identified in the 2013 summer off-peak case.

### Injection Constraints:

Monitored Element	Control Area	kV
630348 H078 161 631107 JASPER 5 161 1	ITC Midwest	161
630334 GRELYTP8 69.0 630024 DUNDEE 8 69.0 1	ITC Midwest	69

### Non-Injection constraints:

Monitored Element	Control Area	kV
631001 TOLEDO 7 115 631012 BL.PLN.7 115 1	ITC Midwest	115
631101 DUNDEE 5 161 631100 LIBERTY5 161 1	ITC Midwest	161
630046 JASPER 8 69.0 630374 AURORA 8 69.0 1	ITC Midwest	69
631107 JASPER 5 161 630046 JASPER 8 69.0 1	ITC Midwest	69
631004 M-TOWN 7 115 932958 BLRSTN 7 115 1	ITC Midwest	115
932958 BLRSTN 7 115 631017 PRAR CK7 115 1	ITC Midwest	115

No voltage violations were observed in any of the analyses performed.

## 1.0 Introduction

The Midwest ISO (MISO) has performed a System Impact Study to evaluate the impact of interconnecting 162 MW of wind generation into the ITC Midwest control area. Steady state thermal and voltage analysis was performed, with and without the proposed generation. The results of these analyses were then compared to determine the impact of the addition of the proposed generation. Section 2 below, describes the study methodology and the criteria used for analyses. The model development and results of the steady-state analysis are presented in Section 3. Higher queued projects included and detailed results are listed in Appendices A and B respectively.

## 2.0 Study Assumptions and Methodology

### 2.1 Study Assumptions

The following assumptions were established prior to starting the study:

- Summer Peak (SUPK) and Summer off-peak (SUOP) cases were developed for this analysis from the respective thermal models used in the Minnesota DPP Cycle 1 (November 2008 cycle) study.
- Wind generation was dispatched at 20% of nameplate in summer peak and 100% of nameplate in summer off-peak conditions, all other generation was dispatched at 100% of expected seasonal capacity as listed ahead:
  - Peaking plants in the vicinity of the new generation were dispatched off in the off-peak case and on in the peak case at 100% nameplate.
  - Base load plants in the vicinity of the group study were dispatched at nameplate in both cases
- Proposed generation in the Midwest ISO interconnection queue have been dispatched by backing down the generation in the MISO east region. MEC queued generators were dispatched against existing MEC generation per merit order.
- The scope of this study was limited to identifying possible thermal and steady state voltage issues caused by the proposed interconnection.

### 2.2 Steady State Analysis

The purpose of the steady-state analysis was to evaluate the impact of H007 & H078 on the transmission system under steady-state conditions. This analysis involved thermal and voltage analysis.

#### 2.2.1 Thermal Analysis

The thermal analysis was performed through MUST's AC contingency analysis tool. The thermal analysis for H007 & H078 was conducted by comparing the transmission system power flows in both the SUPK and SUOP powerflow cases both with and without the proposed generation. All facilities with power flows above the rated limits and TDFs (Transfer Distribution Factors) greater than 5% for system intact conditions and under contingencies were flagged as violations.

The power flows were monitored on all facilities with a voltage of 69 kV and above in the following systems: ITC Midwest, MEC, MPW (control areas 627, 635, and 633). Thermal overloads were defined by power flows over Rate A (normal rating) for system intact conditions and Rate B (emergency rating) under contingencies (for MISO Facilities). Non-MISO MAPP facilities were screened on the Normal Rating for both N-0 and N-1 conditions. These power flows were monitored for system intact conditions

and under a set of contingencies. The contingency analyses included single branch, single unit, and selected multi-element contingencies on facilities in the monitored control areas rated at or above 60 kV. No specific prior outages were provided by the ad-hoc for N-2 analysis.

### 2.2.2 Voltage Analysis

The voltage analysis was performed using AC contingency analysis in MUST. Any voltage deviation between the pre-and post-generator interconnect case greater than 0.01 per unit was noted as a constraint.

## 3.0 Model Development and Analysis

The study models were developed, and the power flow analysis was performed, through the procedure listed below:

- A set of power flow cases was developed to represent the system conditions prior to the addition of H007 & H078. These cases included changes requested by members of the Ad Hoc group for the study, and they also included previously queued generation requests.
- After a set of pre-H007 & H078 cases were developed for both the SUPK and SUOP models, a set of post cases was created by adding the proposed generation to the models. Project H007 was modeled as being connected to the transmission system at the existing Edgewood 69 kV substation and project H078 was modeled as connecting to the transmission system by tapping the existing Marshalltown to Jasper 161 kV line. This generation was then dispatched to the generation in FE, HE, DEM, SIGE, IPL, NIPS, METC, ITCT, CWLD, AMMO, AMIL, CWLP, SIPC control areas.

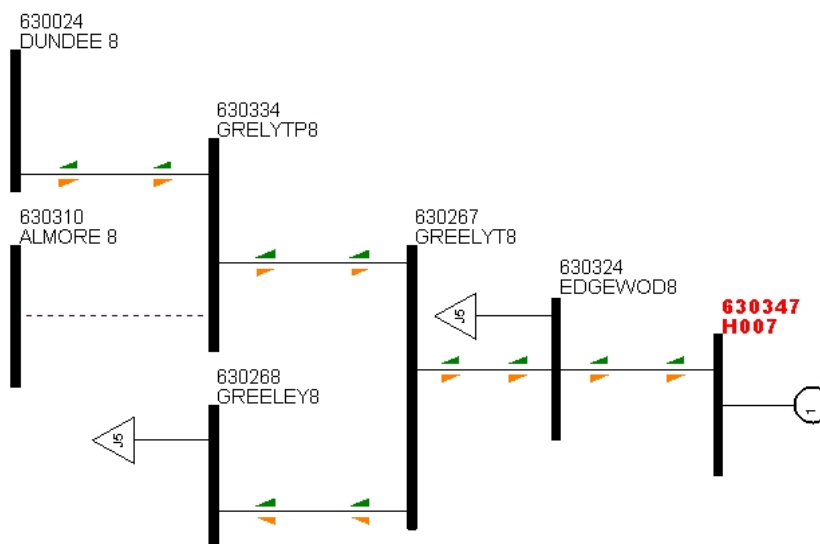

**Figure 1: Modeling of H007 Generation**

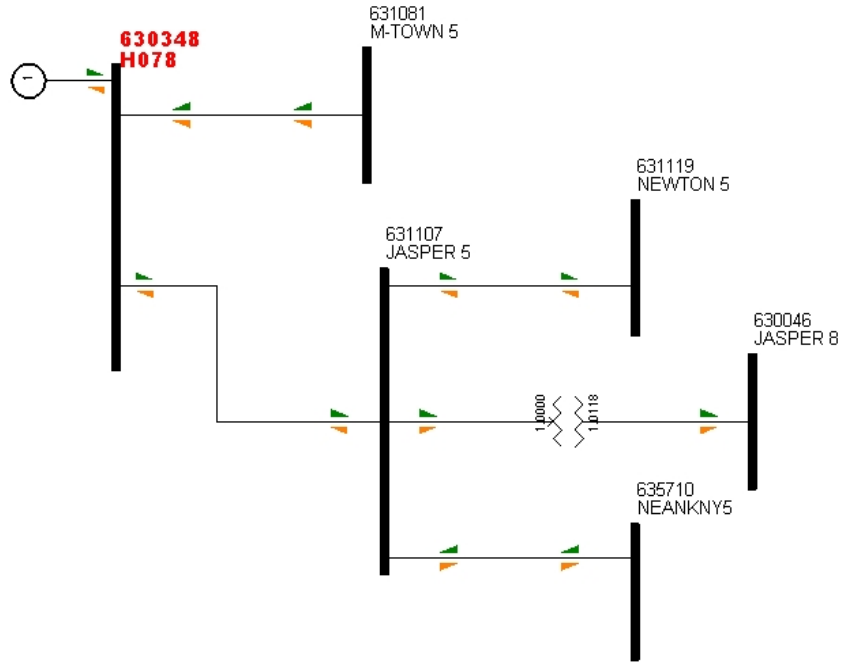

**Figure 2: Modeling of H078 Generation**

A substation schematic indicating breaker layout and proposed generators will be provided in the final report.

- A power flow analysis was performed on the (pre-H007 & H078) SUPK and SUOP models to collect a baseline of data for comparison with the post case. This ensured that all pre-existing thermal and voltage violations were identified and documented.
- Next, analysis was performed on the (post-H007 & H078) SUPK and SUOP models. These results were compared against the baseline results, and the incremental impact of H007 & H078 was determined and documented.

### 3.1 Impact of H007 & H078 on Facility Loadings

Analyses performed on the SUPK case indicated that there were no injection and non-injection related constraints caused by the H007 & H078 interconnection requests.

Analyses performed on the SUOP case indicated that there were injection and non-injection related constraints caused by the H007 & H078 interconnection requests. The following table provides a list of the Injection constraints for a few contingencies. The Distribution Factor (DF) in the table was calculated based on the total transfer level of 162 MW between the pre and post cases.

Impacted Facility	Contingency	Rating (MVA)	Pre Transfer, Post Cont MVA	Post Transfer, Post Cont MVA	Post Transfer, Post Cont % Loading	DF (%)
630348 H078 161 631107 JASPER 5 161 1	631156 STRY_CO5 161 932960 FERNALD5 161 1	223	215.4	281.6	126.3	40.86
630348 H078 161 631107 JASPER 5 161 1	631081 M-TOWN 5 161 631083 TRAER 5 161 1	223	198.9	264	118.4	40.19
630348 H078 161 631107 JASPER 5 161 1	ALTW-C121	223	186.5	250.5	112.3	39.51
630334 GRELYTP8 69.0 630024 DUNDEE 8 69.0 1	630267 GRELYT8 69.0 630268 GREELEY8 69.0 1	24	-0.8	41.2	171.6	25.9
630334 GRELYTP8 69.0 630024 DUNDEE 8 69.0 1	BaseCase	24	-4.1	37.5	156.1	25.67

Facilities adversely impacted by H007 & H078 (per criteria defined earlier) under system intact and contingent conditions are listed in Appendix B.

### 3.2 Impact of H007 & H078 on Bus Voltages

The proposed generation did not cause any voltage violations and it did not aggravate any existing voltage violations. The incremental impact on the bus voltages was insignificant.



## 4.0 Constraint Mitigation

The thermal impact study identified two injection constraints, one for project H007 and one for project H078. The Marshalltown – Jasper 161 kV line was identified as an injection constraint for project H078 and the Greely – Dundee 69 kV line was identified as an injection constraint for project H007.

The Greely – Dundee 69 kV line is currently limited by a CT and relaying at the Dundee substation. The CT and relaying will need to be replaced in order to get to the conductor rating, which is 69 MVA (summer normal). The planning level cost estimate to make this upgrade is \$55,000.

The current limiter for the Marshalltown – Jasper 161 kV line is an 800 A wave trap. The conductor for the line is rated at 327 MVA. In order to reach the conductor limit the wave trap, relaying, and some bus work will need to be replaced at the Marshalltown substation. Also a couple of multi ratio CTs will need to be set to 1200 A.

The following table lists a planning level good faith estimate to mitigate the injection constraints.

**Required Upgrades for ERIS and corresponding planning cost estimates:**

Constrained Facility	Facility Owner	Potential Mitigation	Project responsible for cost	H007 DF%	H078 DF%	Cost Estimate
Marshalltown – Jasper 161 kV line	ITC Midwest	Substation equipment (Wave Trap, relaying, CTs)	H078	5.20	52.77	\$70,000
Greely – Dundee 69 kV line	ITC Midwest	Substation equipment (CT, relaying)	H007	100	0	\$55,000

## 5.0 Conclusions

The impact of adding the study generators H007 & H078 to the system was evaluated. This evaluation involved assessment of system performance based on steady state thermal and voltage analysis. During this study, injection and non-injection related constraints were found that can potentially limit the ability of H007 & H078 to interconnect to or deliver power to the system. A planning level cost estimate to mitigate the injection constraints has been provided.

## Appendix A - Case Development

The Powerflow cases (Summer Peak and Summer Off-Peak) used in the Minnesota DPP Cycle 1 study were used as the starting point for the development of the models used in Iowa DPP Cycle 2 Group study. The following tables list all relevant MTEP 08 Appendix A and B projects added to the case, generator interconnection projects included in the base case and generator interconnection projects added to the base model.

### Future Transmission upgrades from MTEP 08 Appendix A and B

Id	Project Name	Create Date	Review Status	Status	Type
4363	ATC_TtoD_(JUL02)_2008702_Update	7/2/2008	Accepted	correction	Correction
4387	allmods_WAPA_penn-230_remove	7/3/2008	Accepted	Planned	MRO Network
4392	MEC-MRO-project-Correct Welsbrg Gen	7/10/2008	Accepted	Correction	MRO Network
4396	ATC_(339)_Jefferson-Stonybrook_138_kV_and_Ubrates	7/16/2008	Pending Acceptance	Planned	MTEP A
4399	GRE-MRO-SOUTHBRANCH	7/17/2008	Accepted	correction	Correction
4409	MRES-Zx-GenFix-AllMod	7/28/2008	Accepted	Correction	MRO Network
4410	MRES-Benson115	7/28/2008	Accepted	Planned	MRO Network
4413	allmods_p3_wapa_hilken	7/31/2008	Accepted	Planned	MRO Network
4416	ATC_(TtoD)_raymond	8/1/2008	Accepted	Planned	Network
4425	ATC_TtoD_(Z2)_T-D_Norway	8/8/2008	Accepted	Planned	Network
4426	ATC_TtoD_(Z3)_T-D_REE-reconfig	8/8/2008	Accepted	Planned	Network
4427	ATC_TtoD_(AUG03)_20080803_Update	8/8/2008	Accepted	correction	Correction
4428	ATC_TtoD_(Z2)_BigBay_T-D	8/8/2008	Accepted	Proposed	Network
4429	ATC_TtoD_(Z3)_Mazomanie West	8/8/2008	Accepted	Proposed	Network
4430	ATC_TtoD_(Z3)_Nelson Dewey	8/8/2008	Accepted	Proposed	Network
4431	ATC_TtoD_(Z3)_Southwest Verona_T-D	8/8/2008	Accepted	Proposed	Network
4432	ATC_TtoD_(Z4)_LittleSuamico_T-D	8/8/2008	Accepted	Proposed	Network
4454	ATC_TtoD_(AUG02)_20080802_Update	8/19/2008	Accepted	correction	Correction
4456	ATC_TtoD_(AUG20)_20080820_Xfmr_updates	8/21/2008	Accepted	correction	Correction
4457	MH-MRO-StLeon-name	8/22/2008	Accepted	Correction	MRO Network
4464	MEC-MRO-correction-DupLoadPurge	8/22/2008	Accepted	correction	Correction
4466	ATC_(AUG28)_20080828_UpdateS	8/28/2008	Accepted	correction	Correction
4467	ATC_(877)_oc_phase_1_-_oak_creek_xfmr	8/28/2008	Accepted	Proposed	MTEP A
4468	ATC_(SEPT02)_GEN_updates	9/2/2008	Accepted	correction	Correction
4472	MEC-MRO-project-PNYCRK	9/5/2008	Pending Acceptance	Planned	MRO Network
4476	MEC-MRO-correction-SeptMOD	9/5/2008	Accepted	Correction	MRO Network
4479	Brady Updates_DLCO	9/8/2008	Accepted	Planned	MISO Network
4485	ITCM_TRICOUNTY_161-DIST_SUB	9/15/2008	Accepted	Planned	Network
4486	OTP-971-WINGERXFMR-20080613 [08-09-16 09:34]	9/16/2008	Pending Acceptance	Planned	MTEP B
4489	ATC_TtoD_(z4)_Pound_tap_to_B2	9/17/2008	Accepted	correction	Correction
4497	ATC_(TtoD)_Lakota-Con_bus-config	9/23/2008	Accepted	correction	Correction
4500	ATC_(SEPT24)_20080924_Pulliam_g3-g4_offline	9/24/2008	Accepted	correction	Correction
4504	ATC_2112_(Z3)_G546_Bowers-Rd_Wind	9/29/2008	Pending Acceptance	Proposed	MTEP B
4505	ATC_(TtoD)_TD_schofield	9/29/2008	Accepted	Proposed	Network
4508	ATC_1268_(Z3)_Artesian_138_Cap_banks	10/2/2008	Pending Acceptance	Proposed	MTEP B

Id	Project Name	Create Date	Review Status	Status	Type
4509	ATC_1268 (Z3) Kilbourn_138_Cap_banks	10/2/2008	Pending Acceptance	Proposed	MTEP B
4513	WAPA_MRO_BEPC_FiThomp-Storla230Line_purg.prj	10/2/2008	Accepted	correction	Correction
4515	WAPA_MRO_BEPC-Su2009+-SplitWess-Letcher.prj	10/2/2008	Accepted	correction	Correction
4516	WAPA_MRO-2008 bepc-groton-chgs.prj	10/2/2008	Accepted	correction	Correction
4535	MH-MRO-Octbaseupd	10/17/2008	Accepted	Correction	MRO Network
4538	DPC-MRO-UPDATE	10/17/2008	Accepted	Correction	MRO Network
4544	SMP-MISO-LAKECITY-AREA [08-10-18 16:21]	10/18/2008	Pending Acceptance	Planned	Non-Transferred
4545	SMP-MISO-LOADAREA-CORR10-08	10/18/2008	Pending Acceptance	correction	Correction
4546	SMP-MISO-10-08-OWAT-CA FIX	10/18/2008	Pending Acceptance	correction	Correction
4547	SMP-MISO-BLOOM-GEN09 [08-10-19 14:06]	10/19/2008	Pending Acceptance	Planned	Non-Transferred
4553	ATC_(574)_MOC-COC_161-1a	10/20/2008	Pending Acceptance	Proposed	MTEP B
4554	ATC_(OCT20)_20081020_Updates	10/20/2008	Pending Acceptance	correction	Correction
3124	ATC_(339)_Remove_Boxelder_Temporary_Cap_Bank	1/29/2008	Accepted		MTEP A
3154	ATC_(886)_NorthLake_aka_Cedar_retirements_ver2	1/29/2008	Accepted		MTEP A
3203	ATC_(1939)_MEWD_CT_G588	1/29/2008	Accepted		MTEP B
3212	ATC_(TtoD)_IronMountainEast_T-D	1/29/2008	Accepted		Network
3320	ATC_(1705)_Bass_Ck_138-69_Tr_and_X12_RCND	1/30/2008	Accepted		MTEP B
3411	ATC_(TtoD)_3rd_merrill_hills_t-d	2/1/2008	Accepted		Network
3419	ATC_(TtoD)_brookdale_3rd_xfmr	2/1/2008	Accepted		Network
3421	ATC_(877)_oc-phase-1	2/1/2008	Accepted		MTEP A
4234	ATC_(TtoD)_TD_Vienna	5/14/2008	Accepted		Network
4373	ATC_TtoD_(Z3)_T-D_Beloit-Gateway	7/2/2008	Accepted		Network
4018	GRE-MRO-PROJECT-BBP(20143)	3/10/2008	Accepted		MTEP A
3132	ATC_(352)_CON-IRGR138_v29	1/29/2008	Accepted		MTEP A
3422	ATC_(877)_oc-phase-2	2/1/2008	Accepted		MTEP A
4396	ATC_(339)_Jefferson-Stonybrook_138_kV_and_Uprates	7/16/2008	Accepted		MTEP A
4504	ATC_2112_(Z3)_G546_Bowers-Rd_Wind	9/29/2008	Accepted		MTEP B
4545	SMP-MISO-LOADAREA-CORR10-08	10/18/2008	Accepted		Correction
4547	SMP-MISO-BLOOM-GEN09 [08-10-19 14:06]	10/19/2008	Accepted		Non-Transferred
3136	ATC_(356)_ROE-WMD_345_kV_North_Route	1/29/2008	Accepted		MTEP A
3142	ATC_(574)_COC-PET_Uprate	1/29/2008	Accepted		MTEP A
2800	AMMO-MISO-P717-718-ConwayOrchard12	8/2/2007	Accepted		MTEP A
4385	XEL-675-SCOTTCO-WESTGATE	7/3/2008	Accepted		MTEP A
4553	ATC_(574)_MOC-COC_161-1a	10/20/2008	Accepted		MTEP A
4486	OTP-971-WINGERXFMR-20080613 [08-09-16 09:34]	9/16/2008	Accepted		MTEP A
3750	OTP-1033-SLVRK	2/26/2008	Accepted		MTEP A
2952	WPSC-MISO-B-1211_Gnd Trvse-Grawn Rebuild	1/4/2008	Accepted		MTEP A
2954	WPSC-MISO-C_1209-Hersey Tie	1/4/2008	Accepted		MTEP A
2924	WPSC-MISO-B-1213_Vestaburg 6MVAR Cap	1/4/2008	Accepted		MTEP A
2939	WPSC-MISO-C_1219-Lake Cnty-Plains X Rebuild	1/4/2008	Accepted		MTEP A
3601	AMMO-MISO-project1235-FredricktownAECI	2/14/2008	Accepted		MTEP A
3603	AMMO-MISO-project-1238-GMPPointPrairie	2/14/2008	Accepted		MTEP A

<b>Id</b>	<b>Project Name</b>	<b>Create Date</b>	<b>Review Status</b>	<b>Status</b>	<b>Type</b>
2930	WPSC-MISO-C_1274-Blendon-Osipoff Rebuild	1/4/2008	Accepted		MTEP A
4508	ATC_1268_(Z3)_Artesian_138_Cap_banks	10/2/2008	Accepted		MTEP A
4509	ATC_1268_(Z3)_Kilbourn_138_Cap_banks	10/2/2008	Accepted		MTEP A
2931	WPSC-MISO-C_1276-Burnips-Wayland Rebuild	1/4/2008	Accepted		MTEP A
3159	ATC_(1279)_North_Beaver_Dam_Cap_Bank	1/29/2008	Accepted		MTEP A
2933	WPSC-MISO-C_1311-Copemish to Grawn Rebuild	1/4/2008	Accepted		MTEP A
2937	WPSC-MISO-C_1315-Grand Trvse-East Bay Rebuild	1/4/2008	Accepted		MTEP A
3667	ALTW_Salem-Lore-Hazelton-1340_345kV	2/20/2008	Accepted		MTEP A
3696	ALTW_Quad-RkCrk-Salem-1345_Terminals	2/21/2008	Accepted		MTEP A
3635	ALTW_Rock_Creek-1346_345-161kV_Terminal	2/18/2008	Accepted		MTEP A
3541	XEL-1368-1369-1370-NEWRICHMOND	2/9/2008	Accepted		MTEP A
4544	SMP-MISO-LAKECITY-1367-AREA [08-10-18 16:21]	10/18/2008	Accepted		MTEP A
3508	XEL-1371-BLACKDOG-WILSON2-UPGRADE	2/9/2008	Accepted		MTEP A
3542	XEL-1373-NEWULM-TS	2/9/2008	Accepted		MTEP A
4194	XEL-PROJECT-1380-WWACONIA-SCOTTCO-115KV	4/17/2008	Accepted		MTEP A
3520	XEL-1486-MARYLAKE-BUFFALO	2/9/2008	Accepted		MTEP A
3547	XEL-1487-SOMMERSET	2/9/2008	Accepted		MTEP A
3697	ALTW_1522_6th-Beverly_161kV	2/21/2008	Accepted		MTEP A
3622	AMIL-MISO-1529-project-BrokawStrFarm1596	2/15/2008	Accepted		MTEP A
3535	XEL-1545-MANKATO_115KV_LOOP	2/9/2008	Accepted		MTEP A
3701	XEL-1547-IRONWOOD_2ND_TR	2/22/2008	Accepted		MTEP A
3533	XEL-1548-LACROSSE	2/9/2008	Accepted		MTEP A
3539	XEL-1548-MONROECO_CAPBANK	2/9/2008	Accepted		MTEP A
4262	XEL-1549-EAUCLAIRE	6/5/2008	Accepted		MTEP A
2959	CWLP-INTERSTATE-1552-project-09fall_1	1/8/2008	Accepted		MTEP A
3167	ATC_(1553)_Hiawatha_Cap_1x16_3_v29	1/29/2008	Accepted		MTEP A
3169	ATC_(1555)_Perkins_Cap_2x16_3_v29	1/29/2008	Accepted		MTEP A
2929	WPSC-MISO-C_1581-Alba-Advance Rebuild	1/4/2008	Accepted		MTEP A
2934	WPSC-MISO-C_1577-Copemish-Bass Lake Rebuild	1/4/2008	Accepted		MTEP A
2935	WPSC-MISO-C_1586-Gaylord-Advance Rebuild	1/4/2008	Accepted		MTEP A
2955	WPSC-MSIO-C_1587-Gaylord to Oden New 138kV	1/4/2008	Accepted		MTEP A
3698	ALTW_1618_Heron_Lake-Lakefield_161kV	2/21/2008	Accepted		MTEP A
3699	ALTW_Grand_Mound-1619_161kV	2/21/2008	Accepted		MTEP A
3638	ALTW_Ottumwa-1641_161kV_50MVAR	2/19/2008	Accepted		MTEP A
3640	ALTW_Anita-1643_161kV_24MVAR	2/19/2008	Accepted		MTEP A
3641	ALTW_Grand_Junction-1644_161kV_24MVAR	2/19/2008	Accepted		MTEP A
3642	ALTW_Leon-1645_69kV_7MVAR	2/19/2008	Accepted		MTEP A
3176	ATC_(1667)_Pine_River_Ring_Bus_and_Caps	1/29/2008	Accepted		MTEP A
3182	ATC_(1676)_LAnse_Cap_1x4_08	1/29/2008	Accepted		MTEP A
3183	ATC_(1677)_Cornell-Chandler_167F	1/29/2008	Accepted		MTEP A
3184	ATC_(1679)_Richland_Center_Olson_Capacitor_Bank	1/29/2008	Accepted		MTEP A
3186	ATC_(1681)_Uprate_NLG_to_LG_69kV_Line	1/29/2008	Accepted		MTEP A
4502	ATC_(1680)_Walworth-North_Lake_Geneva_69kV_Uprate	9/29/2008	Accepted		MTEP A

Id	Project Name	Create Date	Review Status	Status	Type
4498	ATC_(1682)_Rebuild_Crivitz-HiFalls69kV_T2-336_1of2	9/24/2008	Accepted		MTEP A
4499	ATC_(1682)_Rebuild_Crivitz-HiFalls69kV_T2-336_2of2	9/24/2008	Accepted		MTEP A
3389	ATC_(1683)_Rebuild_SunsetPt-Pearl69kV	1/30/2008	Accepted		MTEP A
3631	ALTW_Arnold-Washburn_1739-161kV_Upgrade	2/18/2008	Accepted		MTEP A
3644	ALTW_Hills-Washington-1755_69kV_Rbld	2/19/2008	Accepted		MTEP A
3645	ALTW_N_Cntrville_69kV-1772_7MVAR	2/19/2008	Accepted		MTEP A
4107	OTP-MTEPC-1792-CSLTN ETHANOL	3/28/2008	Accepted		MTEP A
3199	ATC_(1935)_B-RIDGE-G338_Windfarm	1/29/2008	Accepted		MTEP A
3395	ATC_(1937)_Lafayette-G282_Windfarm(combined)	1/31/2008	Accepted		MTEP A
3206	ATC_(1945)_Upgrade_Sheepskin_Cap_Bank	1/29/2008	Accepted		MTEP A
4206	XEL-1953-SAUKRIVER-STCLOUD	4/24/2008	Accepted		MTEP A
4259	XEL-1954-WSIOUXFALLS-PATHFINDER	6/3/2008	Accepted		MTEP A
4254	XEL-1956-WILMARTH-BLUELAKE	6/3/2008	Accepted		MTEP A
4199	XEL-PROJECT-1957-EAUCLAIRE-P2	4/17/2008	Accepted		MTEP A
4198	XEL-PROJECT-1958-STONELK-COUDERAY161KV	4/17/2008	Accepted		MTEP A
4272	XEL-1959-YANKEEDOODLE-PILOTKNOB	6/12/2008	Accepted		MTEP A
4256	XEL-1960-TRAVERSE-STPETER	6/3/2008	Accepted		MTEP A
4255	XEL-1961_LAKEEMILY_CAP	6/3/2008	Accepted		MTEP A
2979	WPSC-MISO-C_Gray-1965-138-69_Transormer	1/11/2008	Accepted		MTEP A
2946	WPSC-MISO-C_1967-Wayland to Portland Rebuild	1/4/2008	Accepted		MTEP A
4232	ATC_(2057)_Warrens T-D w line ext	5/14/2008	Accepted		MTEP A
3618	AMIL-MISO-project-2058-ConocoPhilip138kV	2/14/2008	Accepted		MTEP A
3619	AMIL-MISO-project2060-EPeoriaFlint	2/14/2008	Accepted		MTEP A
3620	AMMO-MISO-project2061-GraySummit2ndTransformer	2/14/2008	Accepted		MTEP A
3625	AMIL-MISO-project2068-LathamOreanaLine	2/15/2008	Accepted		MTEP A
3621	AMMO-MISO-project2072-BrickHouseSub	2/14/2008	Accepted		MTEP A
3753	OTP-MTEPA-2090-CL115SS	2/26/2008	Accepted		MTEP A
3754	OTP-MTEPA-2091-CASLXKXMR	2/26/2008	Accepted		MTEP A
4384	XEL-2109-G609	7/3/2008	Accepted		MTEP A
4050	XEL-MTEP-PROJECT-2119-G417	3/24/2008	Accepted		MTEP A
3626	AMIL-MISO-1532-project-StallingsMaryville	2/15/2008	Accepted		MTEP A
4559	XEL-PROJECT-BR-CORRECTIONS	10/21/2008	Accepted		Correction
4560	XEL-PROJECT-TROY-HENRY	10/21/2008	Accepted		Non-Transferred
4566	XEL-CORRECTIONS-CAPS	10/21/2008	Accepted		Correction
4571	XCEL-G060-PHASE2	10/21/2008	Accepted		MTEP A
4572	XEL-GRANDMEADOW	10/21/2008	Accepted		MTEP A
4573	XEL-CORRECTIONS-MISC	10/21/2008	Accepted		Correction
4576	XCEL-NEW-TR-DATA	10/21/2008	Accepted		Correction
4590	avon-fix	10/23/2008	Accepted		Network
4591	lakeshore-fix	10/23/2008	Accepted		Network
4592	add-dist-subs	10/23/2008	Accepted		Network
4593	richland-fix	10/23/2008	Accepted		Network
4595	hamil-fix	10/23/2008	Accepted		Network

<b>Id</b>	<b>Project Name</b>	<b>Create Date</b>	<b>Review Status</b>	<b>Status</b>	<b>Type</b>
4596	rating-imp-upd	10/23/2008	Accepted		Network
4599	LES-MRO-MOD-BC-Update2	10/23/2008	Accepted		Correction
4603	WAPA_MRO_hilken_echlund.prj	10/23/2008	Accepted		Correction
4605	WAPA_MRO_W0_loads_delete.prj	10/23/2008	Accepted		Correction
4611	SMP-LITCHGEN-ADD	10/23/2008	Accepted		Non-Transferred
4612	SMP-SV-GEN-ADD	10/23/2008	Accepted		Non-Transferred
4628	2009 Basecase Changes	10/24/2008	Accepted		Correction
4651	GRE-MOD-BASEUPDATE	10/24/2008	Accepted		Correction
4653	SMP-WASECA-L-A-CORR10-24-08	10/25/2008	Accepted		Correction
4655	WAPA_MRO_bus_type2to1.prj	10/27/2008	Accepted		Correction
4672	rating-imp-upd [08-10-30 11:23]	10/30/2008	Accepted		Network
4690	XEL-2157-DOUGLASCO-TR-2	10/31/2008	Accepted		Non-Transferred
4691	XEL-2158-SAUKCENTER-WESTUNION	10/31/2008	Accepted		Non-Transferred
4697	ITCM_1342_Hiawatha-Lws_Flds_161-115kV	10/31/2008	Accepted		MTEP A
4715	ATC_(1470)_Brodhead-South_Monroe_69_kV_Rebuild	10/31/2008	Accepted		MTEP A
4741	XEL-1457-BRIGO	10/31/2008	Accepted		MTEP A
4742	XEL-56-CHISAGO-STCROIXFLS [08-10-31 18:27]	10/31/2008	Accepted		MTEP A
4747	XEL-1285-GLENCOE-WESTWACONIA	10/31/2008	Accepted		MTEP A
5033	GRE-MOD-BASECORRECTION-20081118	11/18/2008	Correction		MISO Network
4904	AMRN-MISO-project-CaseUpdate	11/6/2008	Planned		Correction
4903	AMIL_MISO-2269-project-BloomingtonCap	11/6/2008	Planned		MISO Network
3542	XEL-1373-NEWULM-TS	2/9/2008	Planned		MTEP A
4871	MP-MISO-PROJECT-LL-BAD-PINE-PEQ	11/6/2008	Planned		MTEP A
4868	MP-MISO-Dunka-Load	11/6/2008	Planned		MISO Network
4872	MP-MISO-PROJECT-1482-Pepin-Lk-r2	11/6/2008	Planned		MTEP A
4859	MP-MISO-18L-1292-Upgrade_MP	11/6/2008	Proposed		MTEP B
4939	AMIL-MISO-2472-project-Fargo345 kV substation	11/10/2008	Planned		MISO Network

**Generator Interconnection Projects Included in the Base Model:**

<b>PROJ #</b>	<b>TRNSM PROVIDER</b>	<b>COUNTY</b>	<b>ST</b>	<b>POINT OF INTERCONNECTION</b>	<b>MAX OUTPUT (MW)</b>	<b>FUEL TYPE</b>
DPC-1	DPC	Winnebago	IA	Linden 69 kV	19.8	
11	MEC	Pottawattamie	IA	Council Bluffs Energy Center Unit #3 up-rate	20	Coal
13	MEC	Sac	IA	Little Sioux-Sac County 161 kV line	160	Wind
17	MEC	Louisa	IA	Louisa Up-Rate	30	Coal
19	MEC	Wright	IA	15 MW at existing Sac Wind Farm (aka "Intrepid" or "Clipper") and 50 MW at existing Wall Lake Wind Farm (aka "Century")	50	Wind
20	MEC	Louisa	IA	Louisa Up-Rate	38	Coal

PROJ #	TRNSM PROVIDER	COUNTY	ST	POINT OF INTERCONNECTION	MAX OUTPUT (MW)	FUEL TYPE
21	MEC	Crawford	IA	Monona-Carroll 161 kV line	100	Wind
22	MEC	Pocahontas	IA	Sac County - Pomeroy 161 kV Line	200	Wind
3	MEC	Warren	IA	Norwalk – SE Polk 345 kV Line	610	CC
31	MEC	Adair	IA	Atlantic -Earlham 161 kV line	150	Wind
32	MEC	Pottawattamie	IA	Avoca-Atlantic 161 kV line between Avoca and Walnut, Iowa	150	Wind
33	MEC	Carroll	IA	At Carroll 161 kV Substation	150	Wind
34	MEC	Adair	IA	Council Bluffs-Madison County 354kV line	250	Wind
35	MEC	Pocahontas	IA	Expanding existing wind site (Pocahontas 161 kV substation)	49	Wind
37	MEC	Floyd	IA	Charles City substation 69 kV	39	Wind
40	MEC	Floyd	IA	Charles City substation 69 kV	36	Wind
45	MEC	Adair	IA	Atlantic-Earlham 161 kV line	26	Wind
6	MEC	Pottawattamie	IA	Council Bluffs Energy Center 345 kV Substation	830	Coal
8	MEC	Wright	IA	Wright –Franklin 161 kV Line	150	Wind
G010	MISO	Vigo	IN		500	Gas
G020	MISO	Dakota	MN		147	Coal
G025	MISO	Marion	IN		189	Gas
G032	MISO	Hancock	KY		95	Hydro
G035	MISO	Rock	WI		505	CC
G037	MISO	Murray	MN		36	Wind
G043	MISO	Ramsey	MN		37	Biomass
G044	MISO	Outagamie	WI	Point Beach North Appleton 345kV line	600	CC
G046	MISO	Worth	IA		200	Wind
G056	MISO	Hancock	IA		80	Wind
G057	MISO	Murray	MN		80	Wind
G059	MISO	Beltrami	MN		50	Gas
G060	MISO	Murray	MN		100	Wind
G064	MISO	Hamilton	IN	Noblesville	210	Gas
G072	MISO	Rock	WI		150	CC
G074	MISO	Outagamie	WI		50	Gas
G084	MISO	Lawrence	IN		320	Gas
G093	MISO	Ozaukee	WI		200	CC
G096	MISO	Dane	WI		105	CC
G103	MISO	Sheboygan	WI		370	Gas
G111	MISO	Brown	WI		85	Gas
G113	MISO	Mower	MN	Adams substation	200	Wind
G117	MISO	Douglas	WI		324	Gas
G132	MISO	Dickey	ND	Ellendale Sub 230 kV	180	Wind
G141	MISO	Waterville	MN		46	Gas
G148	MISO	Juneau	WI		19.5	Fuel Oil
G160	MISO	Dane	WI		45	CC
G162	MISO	Murray	MN		200	Wind
G164	MISO	Martin	MN	Lakefield Junction 345 kV	200	Wind

PROJ #	TRNSM PROVIDER	COUNTY	ST	POINT OF INTERCONNECTION	MAX OUTPUT (MW)	FUEL TYPE
				substation		
G165	MISO	Kewaunee	WI		38	Nuclear
G170	MISO	Washington	MN		20	Coal
G171	MISO	Dodge	MN		14	Wind
G172	MISO	Mower	MN	Adams Sub	300	Wind
G173	MISO	Rice	MN		300	Gas
G176	MISO	Lincoln	MN		100	Wind
G185	MISO	Pipestone	MN		4	Wind
G186	MISO	Cerro Gordo	IA		600	CC
G188	MISO	New London	IA		2	Diesel
G218	MISO	Trimble	KY		750	Coal
G225	MISO	Outagamie	WI		60	Gas
G230	MISO	Linn	IA		2	Diesel
G232	MISO	Dickinson	IA		44	Wind
G234	MISO	Jackson	MI		22	CC
G237	MISO	Ramsey	MN		575	CC
G238	MISO	Hennepin	MN		510	CC
G240	MISO	Manitowoc	WI		55	Coal
G241	MISO	Lincoln	MN		1.5	Wind
G242	MISO	Dodge	MN		19	Wind
G251	MISO	Jackson	MN		5.7	Wind
G252	MISO	Murray	MN	GRE Rock River to Chandler Tap 69 kV line	10	Wind
G253	MISO	Rock	MN		12	Wind
G255	MISO	Brookings	SD		100	Wind
G256	MISO	Dawson	MT		45	Gas
G258	MISO	Lee	IA		50	Gas
G261	MISO	Blue Earth	MN		667	CC
G263	MISO	Martin	MN		105	Wind
G270	MISO	Nobles	MN		2	Diesel
G272	MISO	Murray	MN		9.9	Wind
G278	MISO	Pipestone	MN		8	Wind
G282	MISO	Lafayette	WI	Hillman 138 kV line	99	Wind
G285	MISO	Pipestone	MN		9	Wind
G286	MISO	Tama	IA		4	Diesel
G291	MISO	LaMoure	ND		19	Wind
G298	MISO	Dickinson	IA	New proposed switchyard approx. 4 mi S of Triboji Sub	100	Wind
G300	MISO	Jackson	IA		6	Diesel
G301	MISO	Osceola	IA		4	Wind
G310	MISO	Cerro Gordo	IA		8	Wind
G311	MISO	Bowman	ND	Gascoyne Jct. 34.5 kV substation	19	Wind
G330	MISO	Mower	MN		19	Wind
G338	MISO	Dodge	WI	tap Rubicon-Hartford 138kV line	54	Wind
G348	MISO	Cass	IA		2	Diesel
G353	MISO	Fond du Lac	WI	tap Acadian-Forest Junction 345kV line	80	Wind
G354	MISO	Fond du Lac	WI	tap Acadian-Forest Junction 345kV line	80	Wind



PROJ #	TRNSM PROVIDER	COUNTY	ST	POINT OF INTERCONNECTION	MAX OUTPUT (MW)	FUEL TYPE
G355	MISO	West Liberty	IA		6	Diesel
G358	MISO	Faribault County	MN	161kV Winco-Winnebago	36	Wind
G361	MISO	Isanti	MN		210	Gas
G366	MISO	Columbia	WI	Friesland substation	80	Wind
G368	MISO	Dodge/Fond du Lac	WI		200	Wind
G369	MISO	Scott	MN		385	Gas
G370	MISO	Minnehaha	SD	Anson 4	205	Gas
G374	MISO	Nobles	MN	Rushmore 69kV	6.3	Wind
G375	MISO	Cottonwood	MN		20	Wind
G380	MISO	Pierce	ND	115kV line to Rugby Substation	150	Wind
G382	MISO	Pipestone	MN	Chanarambie 115kV	8.25	Wind
G383	MISO	Kewaunee	WI		5	Nuclear
G386	MISO	Martin	MN	Lakefield Substation 345kV	100	Wind
G389	MISO	Sherburne	MN	Elk River 230 kV substation	200	Gas
G390	MISO	Sherburne	MN	Elk River 230 kV substation	100	Gas
G397	MISO	Pipestone	MN	Chanarambie 115kV	4.95	Wind
G398	MISO	Pipestone	MN	Chanarambie 115kV	1.65	Wind
G405	MISO	Goodhue	MN	Cannon Falls sub	350	Gas
G408	MISO	McHenry	ND		12	Wind
G412	MISO	Sangamon	IL	Dallman Substation (138 kV)	200	Coal
G417	MISO	Scott	MN	tap Shakopee-Scott 69 kV line	15	Biomass
G426	MISO	Jackson	MN	Lakefield Jct-Triboji 161kV line	100.5	Wind
G427	MISO	Fond du lac	WI	tap Acadian-Forest Junction 345kV line	98	Wind
G431	MISO	Knox	IN		420	CC
G433	MISO	Goodhue	MN	Prairie Island	19	Nuclear
G434	MISO	Goodhue	MN		19	Nuclear
G436	MISO	Jasper	IL	Newton 345kV	50	Coal
G439	MISO	Benton	IN	138 kV, Goodland Sub	100	Wind
G443	MISO	Lincoln	MN	Buffalo Ridge 115kV	6.6	Wind
G444	MISO	Lincoln	MN	Buffalo Ridge 115kV	4.95	Wind
G475	MISO	Callaway	MO	Callaway Nuclear Station	56	Nuclear
G478	MISO	Madison	IL	Venice Switchyard at breaker position 32H	117	Gas
G479	MISO	Ottawa	MI	Campbell 345kV Substation	15	Coal
G483	MISO	Green Lake	WI	69kV line S.E. of Monroe	50	Wind
G489	MISO	Lyon	MN	New sub near Garvin on Lake Yankton-Lyon County 115kV line	20	Wind
G491	MISO	Pipestone	MN	Chanarambie Substation	100	Wind
G492	MISO	Murray	MN		5.4	Wind
G495	MISO	Washington	IL	Prairie State	150	Coal
G502	MISO	Oliver	ND	Milton S Young Station #2 Switchyard Center Bus Substation	50	Wind
G503	MISO	Huron	MI	Sanduskey-Wyatt 120 kV line	158	Wind

PROJ #	TRNSM PROVIDER	COUNTY	ST	POINT OF INTERCONNECTION	MAX OUTPUT (MW)	FUEL TYPE
G507	MISO	Fond du Lac	WI	Near intersection of 138kV line X-2 (OHM-MUR), 345kV line W-1 (SFL-EDG), and 345kV line 971L51 (FJT-ADN)	68	Wind
G514	MISO	Jackson	MN	Lakefield Station via Trimont G263 Interconnect	150	Wind
G515	MISO	Tazewell	IL	Ameren Mason-Tazewell 138kV line 3.5 miles west of Delavan	100	Wind
G519	MISO	Itasca	MN	Blackberry 230/115kV Substation	600	Coal
G520	MISO	Lyon	MN	New sub tapping Lake Yankton-Lyon County 115kV line	150	Wind
G526	MISO	Huron	MI	Cosmo Tap, Bad Axe-Arrowhead 120kV line	52	Wind
G527	MISO	Grant	WI	Nelson-Dewey Generating Station Sub	280	Coal
G530	MISO	Greene	IA	Jefferson - Grand Jct. 34.5 kV line owned by Alliant	14	Wind
G535	MISO	Fulton	IL	Duck Creek Power Station	16	Coal
G538	MISO	Dickinson	IA	Lakefield Jct-Triboji 161kV line	50	Wind
G540	MISO	Worth	IA	Adams to Lime Ck line (161 kV)	80	Wind
G543	MISO	Beaver	PA	Existing Mansfield Three POI	50	Coal
G546	MISO	Walworth	WI	Sugar Creek Substation (138 kV)	100	Wind
G547	MISO	Miller	MO	Osage Switchyard	15	Hydro
G548	MISO	Worth	IA	161 kV ALTW line	80	Wind
G549	MISO	Pope	MN	Next to Williams Substation (69 kV)	20	Wind
G550	MISO	Jefferson	WI	Concord Generating Station	24	Gas
G551	MISO	Howard	IA	Rice 161 kV bus	100	Wind
G552	MISO	Emmet	IA	Maple Hill Substation 69 kV	50	Wind
G555	MISO	Stevens	MN	2 miles north of the Morris substation on the Morris - Grand Co. 115 kV line	100	Wind
G562	MISO	Eau Claire	WI	Dells Hydro Plant	1.3	Hydro
G563	MISO	Eau Claire	WI	Dells Hydro Plant	2.6	Hydro
G564	MISO	Eau Claire	WI	Dells Hydro Plant	2.6	Hydro
G566	MISO	Missaukee	MI	Cadillac - Leroy 69 kV line	2.5	Wind
G573	MISO	Franklin	IA	Franklin Sub (161 kV)	80	Wind
G574	MISO	Franklin	IA	Franklin Sub	80	Wind
G575	MISO	Franklin	IA	Franklin Sub	40	Wind
G576	MISO	Rock	MN	Split Rock ~ Magnolia 161 kV line	40	Wind
G579	MISO	Jefferson	OH	WH Sammis Unit 6	20	Coal
G580	MISO	Jefferson	OH	WH Sammis Plant Unit 7	20	Coal
G586	MISO	Lincoln	MN	Xcel New Yankee Sub 34.5	30	Wind

PROJ #	TRNSM PROVIDER	COUNTY	ST	POINT OF INTERCONNECTION	MAX OUTPUT (MW)	FUEL TYPE
				kV		
G587	MISO	Sibley	MN	69 kV to Winthrop Sub	20	Wind
G587	MISO	Sibley	MN	69 kV to Winthrop Sub	20	Wind
G593	MISO	Jackson	MN	Lakefield Junct. - Triboji 161 kV	100	Wind
G594	MISO	Jackson	MN	Lakefield Junct. - Triboji 161 kV	50	Wind
G595	MISO	Hancock	IA	Lime Creek sub 161 kV	150	Wind
G602	MISO	Nobles	MN	Nobles County Sub along 161 kV NSP trans line.	32	Wind
G604	MISO	Steele	MN	Owatonna - County Line 69 kV	44	Wind
G608	MISO	Pope	MN	GRE Lake Johanna - Broten line (69 kV) 1/2 mile from Lake Johanna Sub	6	Wind
G609	MISO	Price	WI	Flambolt Hydro Park Falls plant	6.3	Hydro
G612	MISO	Story	IA	ALTW 115 kV Fernald Substation	150	Wind
G614	MISO	Emmet	IA	Lakefield Jct - Fox Lake 161 kV #2 line	200	Wind
G617	MISO	Blue Earth	MN	Amboy to Willow Ck 69 kV line (BE-WCT)	50	Wind
G618	MISO	Yellow Medicine	MN	Burr Jct to Toronto 115 kV line located 5 miles from Camby	138	Wind
G619	MISO	Otter Tail	MN	41 kV at Tamarac Sub (GRE)	50	Wind
G620	MISO	Goodhue	MN	Kenyon - Dodge 69 kV	19	Wind
G621	MISO	Pipestone	MN	Golf to Wookstock 34.5 kV line - feeder 311	20	Wind
G626	MISO	Brown	MN	Morgan to Sleepy Eye line #0719 69 kV	32	Wind
G628	MISO	Brown	MN	Comfrey - Mountain Lake 69 kV line	32	Wind
G630	MISO	Big Stone	MN	Artichoke Sub 41.6 kV	21	Wind
G631	MISO	Nobles	MN	69 kV Adrian to Adrian Tap line	19	Wind
G632	MISO	Nobles	MN	Magnolia to Worthington 69 kV line near I 90	19	Wind
G633	MISO	Nobles	MN	161 kV Elk to Magnolia line	19	Wind
G637	MISO	Traverse	MN	OTP Graceville to Wapton line (115 kV)	20	Wind
G638	MISO	Stevens	MN	OTP 41 kV Graceville to Morris line	20	Wind
G640	MISO	Todd	MN	R34T133 Sec 30 Bartlett Township Substation	30	Wind
G641	MISO	Cook	MN	Colville Sub	18	Diesel
G646	MISO	Pike	IN	Petersburg Generation Plant	30	Coal
G657	MISO	Pope	MN	Glenwood 69 kV sub	20	Wind
G658	MISO	Pope	MN	Westport 69 kV sub	20	Wind
G667	MISO	Jackson	MN	Round Lake Tap 69 kV sub	20	Wind

PROJ #	TRNSM PROVIDER	COUNTY	ST	POINT OF INTERCONNECTION	MAX OUTPUT (MW)	FUEL TYPE
G674	MISO	Knox	IN	Wheatland - AMO 345 kV	80	Coal
G675	MISO	Knox	IN	Wheatland - AMO 345 kV	200	Coal
G685	MISO	Meeker	MN	Lake Lillian - Atwater 69 kV line tap, 1.4 miles SE of Atwater	20	Wind
G726	MISO	Linn	IA	Duane Arnold Energy Center	30	Nuclear
G743	MISO	Missaukee	MI	WPSC Cadillac-Leroy 69kV line	45	Wind
G789	MISO	Pope	MN	T-126-N, R-36-W	20	Wind
G809	MISO	Midland	MI	Tittabawassee Substation 345kV	193	Gas
G812	MISO	Pope	MN	69 kV line in SW 1/4 of section 27 in Rolling Forks Twp.	20	Wind
G820	MISO	Presque Isle	MI	Port Calcite-Rockport 138kV line	600	Coal
G843	MISO	Otter Tail	MN	R37T131 Sec 3 Parkers Prairie Twp near the junction of State Highway 29 and Co Rd 138	100	Wind
G848	MISO	Livingston	KY	Renshaw-Livingston 161 kV line	80	Hydro
G858	MISO	Stearns	MN	POI is the Xcel Black Oak Switching Station on County Road 186 in Section 6 of Grove Township	38	Wind
G868	MISO	Fulton	IL	Existing AERG Duck Creek Plant	23	Coal
G873	MISO	Kittson	MN	41.6 kV line between Kennedy and Donaldson (R48WT159N, Sec 7,8, Davis Twp)	20	Solar
G875	MISO	Kittson	MN	115 kV line between Donaldson and Warsaw (R49WT159N, SE 1/4 of Sec 35)	80	Wind
G876	MISO	McLean	ND	Coal Creek 230 kv substation	25	Coal
G877	MISO	McLean	ND	Coal Creek 230 kv substation	40	Coal
G889	MISO	Huron	MI	Cosmo Tap (Bad Axe-Arrowhead) 120kV	59.4	Wind
G904	MISO	Rolette	ND	Rugby-Glenboro 230kV	150	Wind
G922	MISO	Carroll	IL	York Substation 161kV bus	111.65	Biomass
G929	MISO	Wright	MN	Monticello Substation	61	Nuclear
G931	MISO	Iroquois	IL	Watseka-Goodland 138kV line	150	Wind
G937	MISO	Delta	MI	tap Indian Lake-Perkins 138kV double-circuit line	200	Wind
G971	MISO	Meeker	MN	69 kV line in SE 1/4 of Sec 17 in Cosmos Twp	20	Wind
G983	MISO	Jasper	IL	AEG Newton Unit 2 345kV	42	Coal
G984	MISO	Jasper	IL	AEG Newton Unit 1 345kV	42	Coal
G996	MISO	Ford	IL	Paxton East 138kV	150	Wind

PROJ #	TRNSM PROVIDER	COUNTY	ST	POINT OF INTERCONNECTION	MAX OUTPUT (MW)	FUEL TYPE
				Substation		
H012	MISO	Columbia	WI	Hamilton St. - N. Randolph 138 kV line tap	150	Wind
H048	MISO	Stearns	MN	Xcel 34.5 kV Paynesville transmission substation	50	Wind
H049	MISO	Stearns	MN	GRE Albany Substation at 69 kV	45	Wind
H058	MISO	Stearns	MN	Adjacent to the GRE Zion 69kV substation	45	Wind
H061	MISO	Goodhue	MN	Vasa 69 kV substation	39	Wind
H062	MISO	Goodhue	MN	Goodhue 69 kV Substation	39	Wind
H067	MISO	Kandiyohi	MN	GRE's 69 kV Atwater sub	40	Wind
H071	MISO	Stearns	MN	XCEL's Black Oak 69 kV sub	40	Wind
H074	MISO	Goodhue	MN	69kV at Goodhue Substation	50	Wind
H075	MISO	Ocean	MI	At or near the Redwood Substation either on 69 kV (Wolverine) or 138 kV (ITC) lines	60	Wind
H092	MISO	Itasca	MN	Existing Boswell Substation	60	Coal
H093	MISO	Mahoning	OH	as close to the step up transformer as possible (?)	4.8	Landfill Gas
H100	MISO	Vermillion	IL	Vermillion 138kV substation	200	Wind
H101	MISO	Beltrami	MN	1.5 miles north of Solway, MN; T-147-N, R-35-W	50	Natural Gas
GI-0215	WAPA	Cass	IA	Exira 161kV	140	Gas

**Generator Interconnection Projects added to the Base Model**

<b>PROJ #</b>	<b>TRNSM PROVIDER</b>	<b>COUNTY</b>	<b>ST</b>	<b>POINT OF INTERCONNECTION</b>	<b>MAX OUTPUT (MW)</b>	<b>FUEL TYPE</b>
15	MEC	Pocahontas	IA	Pomeroy 161 kV Substation	80MW	Wind
23	MEC	Crawford	IA	Monona-Carroll 161 kV Line	100 MW	Wind
25	MEC	Crawford ( Bus Carroll)	IA	Monona-Carroll 161 kV line	100 MW revised to 50 MW	Wind
28	MEC	Henry	IL	Substation 39 to Substation 43 161 kV line or at the 69 kV Substation 27. Revised to interconnection point to MidAmerican's 69 kV Substation 27 with a maximum power output of 100 MW for the SIS	100 MW	Wind
29	MEC	Crawford	IA	Monona-Carroll 161 kV Line	100.8 MW	Wind
30	MEC	Carroll	IA	Templeton 69 kV Substation	20 MW	Wind
36	MEC	O'Brien (City Sanborn)	IA	Sanborn 69 kV	100 MW	Wind
38	MEC	Adair	IA	Council Bluffs – Grimes 345 kV line	200 MW	Wind
41	MEC	Adair	IA	Council Bluffs – Grimes 345 kV line	100 MW	Wind

## Appendix B - Power Flow Results

Injection and Non-Injection Constraints for 2013 Summer Peak Case: None

Injection and Non-Injection Constraints for 2013 Summer Off-Peak Case: For each Impacted Facility only the five highest DFs are reported

Impacted Facility	Contingency	Rating (MVA)	Pre Transfer, Post Cont MVA	Post Transfer, Post Cont MVA	Post Transfer, Post Cont % Loading	DF <sup>1</sup> (%)
630348 H078 161 631107 JASPER 5 161 1	631156 STRY_CO5 161 932960 FERNALD5 161 1	223	215.4	281.6	126.3	40.86
630348 H078 161 631107 JASPER 5 161 1	631081 M-TOWN 5 161 631083 TRAER 5 161 1	223	198.9	264	118.4	40.19
630348 H078 161 631107 JASPER 5 161 1	ALTW-C121	223	186.5	250.5	112.3	39.51
630348 H078 161 631107 JASPER 5 161 1	932960 FERNALD5 161 932961 AMES 5 161 1	223	194.4	258.3	115.8	39.44
630348 H078 161 631107 JASPER 5 161 1	631001 TOLEDO 7 115 631004 M-TOWN 7 115 1	223	194.5	257.3	115.4	38.77
630334 GRELYTP8 69.0 630024 DUNDEE 8 69.0 1	630267 GRELYT8 69.0 630268 GREELEY8 69.0 1	24	-0.8	41.2	171.6	25.9
630334 GRELYTP8 69.0 630024 DUNDEE 8 69.0 1	BaseCase	24	-4.1	37.5	156.1	25.67
631001 TOLEDO 7 115 631012 BL.PLN.7 115 1	630348 H078 161 631107 JASPER 5 161 1	80	86.6	104.4	130.5	10.99
631101 DUNDEE 5 161 631100 LIBERTY5 161 1	631139 HAZLTON3 345 631145 LORE 3 345 1	167	160.5	176.6	105.7	9.94
630046 JASPER 8 69.0 630374 AURORA 8 69.0 1	631107 JASPER 5 161 631119 NEWTON 5 161 1	72	84.1	97.5	135.5	8.27
631107 JASPER 5 161 630046 JASPER 8 69.0 1	631107 JASPER 5 161 631119 NEWTON 5 161 1	84	86.6	100	119	8.27
631004 M-TOWN 7 115 932958 BLRSTN 7 115 1	630348 H078 161 631107 JASPER 5 161 1	60	72.3	85.1	141.8	7.9
932958 BLRSTN 7 115 631017 PRAR CK7 115 1	630348 H078 161 631107 JASPER 5 161 1	60	58.9	71.2	118.6	7.59
631001 TOLEDO 7 115 631012 BL.PLN.7 115 1	631081 M-TOWN 5 161 631083 TRAER 5 161 1	80	74.5	86.7	108.4	7.53
631001 TOLEDO 7 115 631012 BL.PLN.7 115 1	631004 M-TOWN 7 115 932958 BLRSTN 7 115 1	80	77.2	89.1	111.4	7.35
631001 TOLEDO 7 115 631012 BL.PLN.7 115 1	631107 JASPER 5 161 631119 NEWTON 5 161 1	80	70.6	82.3	102.9	7.22
631001 TOLEDO 7 115 631012 BL.PLN.7 115 1	631117 REASNOR5 161 631119 NEWTON 5 161 1	80	68.6	80.3	100.4	7.22
631004 M-TOWN 7 115 932958 BLRSTN 7 115 1	631001 TOLEDO 7 115 631004 M-TOWN 7 115 1	60	72.9	82.4	137.3	5.86
932958 BLRSTN 7 115 631017 PRAR CK7 115 1	631001 TOLEDO 7 115 631004 M-TOWN 7 115 1	60	59.8	68.9	114.8	5.62
631004 M-TOWN 7 115 932958 BLRSTN 7 115 1	631081 M-TOWN 5 161 631083 TRAER 5 161 1	60	63.4	72.1	120.2	5.37
631004 M-TOWN 7 115 932958 BLRSTN 7 115 1	631117 REASNOR5 161 631119 NEWTON 5 161 1	60	59.5	68	113.3	5.25
631004 M-TOWN 7 115 932958 BLRSTN 7 115 1	631107 JASPER 5 161 631119 NEWTON 5 161 1	60	61	69.4	115.7	5.19

<sup>1</sup> The Distribution Factor (DF) in the table was calculated based on the total transfer level of 162 MW between the pre and post cases.

## Appendix C - Multi-Element Contingencies

COM '906 Defined as multi-terminal, Interregional'  
 COM 'A 636640-636645 LOUISA 3-SUB T 3 OPENS B C'  
 COM 'B 636645-636400 SUB T 3-HILLS 3 OPENS A C'  
 COM 'C 636645-345435 SUB T 3-PALM TAP See next cont.'  
 COM '-----'  
 CONTINGENCY '906 '  
 TRIP LINE FROM BUS 636640 TO BUS 636645 CKT 1  
 TRIP LINE FROM BUS 636645 TO BUS 636400 CKT 1  
 TRIP LINE FROM BUS 636645 TO BUS 345435 CKT 1  
 END

COM '-----'  
 COM '910 Defined as multi-terminal'  
 COM 'A 636400-636420 HILLS 3-TIFFIN 3 OPENS B,C'  
 COM 'B 636420-636421 TIFFIN 3-TIFFIN 5 OPENS VLD SGL'  
 COM 'C 636420-631142 TIFFIN 3-ARNOLD 3 OPENS A B'  
 COM 'The Hills-Tiffin 345 kV line 'A' is breakerred individually'  
 COM 'and could be onsidered a valid single outage. However, I '  
 COM 'believe we show this multi-terminal outage due to the '  
 COM 'reverse power relay on the Tiffin transformer that we '  
 COM 'discussed previously. Therefore, I would say that this'  
 COM 'multi-terminal outage is valid.'  
 COM 'Let me know if you have questions.'  
 COM 'Ken'  
 COM '' '  
 COM 'Note:'  
 COM 'If the base case flow is from Tiffin to Hills 345 kV'  
 COM 'the Hills-Tiffin 345 kV outage is valid.'  
 COM '' '  
 COM 'If the base case flow if from Hills to Tiffin 345 kV"  
 COM 'the Hills-Tiffin 345 kV is NOT a valid outage.'  
 COM '-----'  
 CONTINGENCY '910 '  
 TRIP LINE FROM BUS 636400 TO BUS 636420 CKT 1  
 TRIP LINE FROM BUS 636420 TO BUS 636421 CKT 1



TRIP LINE FROM BUS 636420 TO BUS 631142 CKT 1  
END

COM '911 Defined as multi-terminal, Interregional'  
COM 'A 652560-631069 CRESTON5-ANITA 5 CKT 1 OPENS B C'  
COM 'B 658000-631069 OR TRAIL5-ANITA 5 CKT 1 OPENS A C'  
COM 'C 631069-631070 ANITA 5-ANITA TP CKT 1 OPENS A B'  
COM '-----'  
CONTINGENCY '911 '  
TRIP LINE FROM BUS 652560 TO BUS 631069 CKT 1  
TRIP LINE FROM BUS 652603 TO BUS 631069 CKT 1  
TRIP LINE FROM BUS 631069 TO BUS 631070 CKT 1  
END

COM 'Waterloo Area Special Contingencies'  
COM 'NOTE: Beginning in 2000 cases'  
COM '926 Defined as Multi-Circuit'  
COM 'A 636200-636202 BLKHAWK5-MIDPORT5 OPENS B'  
COM 'B 636202-636203 MIDPORT5-LUNDQST5 OPENS A'  
COM '-----'  
CONTINGENCY '926 '  
TRIP LINE FROM BUS 636200 TO BUS 636202 CKT 1  
TRIP LINE FROM BUS 636202 TO BUS 636203 CKT 1  
END

COM '927 Defined as multi-terminal'  
COM 'A 635680-635690 BONDRNT3- GDMEC OPENS B C'  
COM 'B 635680-635700 BONDRNT3-SYCAMOR3 OPENS A C'  
COM 'C 635680-635730 BONDRNT3-MNTZUMA3 VLD SGL'  
COM '-----'  
CONTINGENCY '927 '  
TRIP LINE FROM BUS 635690 TO BUS 635680 CKT 1  
TRIP LINE FROM BUS 635680 TO BUS 635700 CKT 1  
TRIP LINE FROM BUS 635680 TO BUS 635730 CKT 1  
END

```

COM '956 Defined as multi-terminal'
COM 'A 636410-636405 SB PIC 5-SB GIC 5 CKT 1 OPENS B,C'
COM 'B 636405-636404 SB GIC 5-SB YIC 5 CKT 1 OPENS A,C'
COM 'C 636404-636403 SB YIC 5-SB EIC 5 CKT 1 OPENS A,B'
COM '-----'
CONTINGENCY '956 '
TRIP LINE FROM BUS 636410 TO BUS 636405 CKT 1
TRIP LINE FROM BUS 636405 TO BUS 636404 CKT 1
TRIP LINE FROM BUS 636404 TO BUS 636403 CKT 1
END

COM '908 Defined as multi-terminal, Interregional'
COM 'A 636645-345435 SUB T 3-PALM TAP CKT 1 OPENS B C D'
COM 'B 345435-345992 PALM TAP-SPENCER CKT 1 OPENS '
COM 'B 345992-345230 SPENCER-MONTGMRY CKT 1 OPENS A C D'
COM '-----'
CONTINGENCY '908-1'
TRIP LINE FROM BUS 636645 TO BUS 345435 CKT 1
TRIP LINE FROM BUS 345435 TO BUS 345992 CKT 1
TRIP LINE FROM BUS 345992 TO BUS 345230 CKT 1
END

COM 'ALTW-C100 MULTI-TERMINAL'
COM 'A 603016-602005 SPLIT R7-SPLIT R5 OPENS B C D E'
COM 'B 602005-631038 SPLIT R5-MAGNLIA5 OPENS A C D E'
COM 'C 631038-631039 MAGNLIA5-ELK 5 OPENS A B D E'
COM 'D 631039-618900 ELK 5-BREWSTR5 OPEND A B C E'
COM 'D 618900-631040 BREWSTR5-HRN LK 5 OPEND A B C E'
COM 'E 631040-630066 HRN LK 5-HERONLK8 CKT 1'
COM '-----'
CONTINGENCY 'ALTW-C100'
TRIP LINE FROM BUS 603016 TO BUS 602005 CKT 6
TRIP LINE FROM BUS 602005 TO BUS 602039 CKT 1
TRIP LINE FROM BUS 602039 TO BUS 631038 CKT 1
TRIP LINE FROM BUS 631038 TO BUS 932994 CKT 1
TRIP LINE FROM BUS 932994 TO BUS 631039 CKT 1
TRIP LINE FROM BUS 631039 TO BUS 618900 CKT 1

```

END

COM 'ALTW-C101 MULTI-TERMINAL'

COM 'A 615306-601002 PL VLLY3-ADAMS 3 OPENS B C'

COM 'B 601002-631046 ADAMS 3-ADAMS 5 OPENS A C'

COM 'C 601002-631139 ADAMS 3-HAZLTON3 VLD SGL'

COM '-----'

CONTINGENCY 'ALTW-C101'

TRIP LINE FROM BUS 615306 TO BUS 601002 CKT 1

TRIP LINE FROM BUS 601002 TO BUS 631046 CKT 1

TRIP LINE FROM BUS 601002 TO BUS 631144 CKT 1//121808LS: Replaced HAZLTON3 (631139) with G172\_WF3 (631144), which taps the 601002 - 631139

END

COM 'ALTW-C102 MULTI-TERMINAL'

COM 'A 652560-631069 CRESTON5-ANITA 5 CKT 1 OPENS B C'

COM 'B 652603-631069 EXIRA 5-ANITA 5 CKT 1 OPENS A C'

COM 'C 631069-631070 ANITA 5-ANITA TP CKT 1 OPENS A B'

COM '-----'

CONTINGENCY 'ALTW-C102'

TRIP LINE FROM BUS 652560 TO BUS 631069 CKT 1

TRIP LINE FROM BUS 652603 TO BUS 631069 CKT 1

TRIP LINE FROM BUS 631069 TO BUS 631070 CKT 1

END

COM 'ALTW-C104 MULTI-TERMINAL'

COM 'A 631050-613420 HAZLETON-WINDSOR5 CKT 1 OPENS B'

COM 'B 613420-681530 WINDSOR5-POSTVIL5 CKT 1 OPENS A'

COM '-----'

CONTINGENCY 'ALTW-C104'

TRIP LINE FROM BUS 631050 TO BUS 613420 CKT 1

TRIP LINE FROM BUS 613420 TO BUS 681530 CKT 1

END

COM 'ALTW-C107 MULTI-TERMINAL'

COM 'A 631042-613370 FOX LK 5-RUTLAND5 CKT 1 OPENS B C'

COM 'B 613370-631043 RUTLAND5-WINBAGO5 CKT 1 OPENS A C'

COM 'C 613370-613350 RUTLAND5-RUTLAND CKT 1 OPENS A B'

COM '-----'

CONTINGENCY 'ALTW-C107'

TRIP LINE FROM BUS 631042 TO BUS 613370 CKT 1//121808LS: Changed ckt ID from P1 to 1

TRIP LINE FROM BUS 613370 TO BUS 631043 CKT 1//121808LS: Changed ckt ID from P1 to 1

TRIP LINE FROM BUS 613370 TO BUS 613350 CKT 1

END

COM 'ALTW-C108 MULTI-TERMINAL'

COM 'A 631123-681527 ADAMS\_S5-BVR CRK5 CKT 1 OPENS B C'

COM 'B 681527-681528 BVR CRK5-HARMONY5 CKT 1 OPENS A C'

COM 'C 613330-681527 RICE 5-BVR CRK5 CKT 1 OPENS A B'

COM '-----'

CONTINGENCY 'ALTW-C108'

TRIP LINE FROM BUS 631123 TO BUS 681527 CKT 1

TRIP LINE FROM BUS 681527 TO BUS 681528 CKT 1

TRIP LINE FROM BUS 613330 TO BUS 681527 CKT 1

END

COM 'ALTW-C109 MULTI-TERMINAL'

COM 'A 631084-344290 VIELE 5-CARBID T CKT 1 OPENS B C D'

COM 'B 344290-345827 CARBID T-TRIVER T CKT 1 OPENS A C D'

COM 'C 345827-345437 TRIVER T-PALMYRA CKT 1 OPENS A B D'

COM 'D 631075-344290 CARBIDE5-CARBID T CKT 1 OPENS A B C'

COM '-----'

CONTINGENCY 'ALTW-C109'

TRIP LINE FROM BUS 631084 TO BUS 344290 CKT 1

TRIP LINE FROM BUS 344290 TO BUS 631075 CKT 1

TRIP LINE FROM BUS 631075 TO BUS 631076 CKT 1

TRIP LINE FROM BUS 631076 TO BUS 345827 CKT 1

TRIP LINE FROM BUS 345827 TO BUS 345437 CKT 1

END

COM 'ALTW-C116 MULTI-TERMINAL AND COMMON ROW'  
COM 'A 631064-636667 BVR CH 5-SUB 49 5 CKT 1 OPENS B RW'  
COM '\*\* Defined as multi-terminal'  
COM 'B 631064-631067 BVR CH 5-ALBANY 5 CKT 1 OPENS A RW, MTL'  
COM 'C 631067-631033 ALBANY 5-ALBANY 6 CKT 1 SGL'  
COM 'D 631067-631068 ALBANY 5-YORK 5 CKT 1 MTL'  
COM 'E 631066-631068 SAVANNA5-YORK 5 CKT 1 MTL'  
COM 'F 631068-629121 YORK 5-YORK 9 CKT 1 SGL'  
COM 'G 631066-629116 SAVANNA5-SAVNA S9 CKT 1 SGL'  
COM '-----'  
CONTINGENCY 'ALTW-C116'  
COM 'Combination RW and MTL'  
TRIP LINE FROM BUS 631064 TO BUS 636667 CKT 1  
TRIP LINE FROM BUS 631064 TO BUS 631067 CKT 1  
TRIP LINE FROM BUS 631067 TO BUS 631033 CKT 1  
TRIP LINE FROM BUS 631067 TO BUS 631068 CKT 1  
TRIP LINE FROM BUS 631066 TO BUS 631068 CKT 1  
TRIP LINE FROM BUS 631068 TO BUS 629121 CKT 1  
TRIP LINE FROM BUS 631066 TO BUS 629116 CKT 1  
END

COM 'ALTW-C121 MULTI-TERMINAL'  
COM 'A 631002-631010 AMES 7-BNE JCT7 CKT 1  
COM 'B 631010-631003 BNE JCT7-BOONE 7 CKT 1  
COM 'C 631079-631010 BNE JCT5-BNE JCT7 CKT 2  
COM 'D 631079-631010 BNE JCT5-BNE JCT7 CKT 3  
COM '-----'  
CONTINGENCY 'ALTW-C121'  
TRIP LINE FROM BUS 932961 TO BUS 631079 CKT 1  
TRIP LINE FROM BUS 631079 TO BUS 932947 CKT 1  
TRIP LINE FROM BUS 932962 TO BUS 631079 CKT 1  
TRIP LINE FROM BUS 932962 TO BUS 629109 CKT 1  
TRIP LINE FROM BUS 932962 TO BUS 629109 CKT 2  
END

COM 'ALTW-C123 MULTI-TERMINAL'  
COM 'A 631073-631092 MT VERN5-BERTRAM5 CKT 1 OPENS B'  
COM 'B 631073-631099 MT VERN5-WYOMING5 CKT 1 OPENS A'  
COM '-----'  
CONTINGENCY 'ALTW-C123'  
TRIP LINE FROM BUS 631073 TO BUS 631092 CKT 1  
TRIP LINE FROM BUS 631073 TO BUS 631099 CKT 1  
END

COM 'ALTW-C124 MULTI-TERMINAL'  
COM 'A 631072-629113 GU CTR 5-GU CTR 9 CKT 1 OPENS B C D'  
COM 'B 631072-631071 GU CTR 5-SCRANTN5 CKT 1 OPENS A C D'  
COM 'C 631072-631070 GU CTR 5-ANITA 5 CKT 1 See Cont ALTW-C125'  
COM '-----'  
CONTINGENCY 'ALTW-C124'  
TRIP LINE FROM BUS 631072 TO BUS 629113 CKT 1  
TRIP LINE FROM BUS 631072 TO BUS 631071 CKT 1  
TRIP LINE FROM BUS 631072 TO BUS 631070 CKT 1  
END